

# BRAKE LOCK

Electric Activated

## Installation and Service Instructions



**BRAKE FLUID  
MODEL NUMBERS**  
02-620-009  
02-620-173

**MINERAL BASED HYDRAULIC OIL  
MODEL NUMBERS**  
02-620-172

BE SURE TO READ GENERAL INSTALLATION GUIDELINES SHEET (81-600-001) BEFORE PROCEEDING

### **▲ WARNING**

1. All MICO locking devices are **supplemental** safety equipment which provide additional brake holding action **when used with existing vehicle parking brake.**
2. The Low Pressure Warning Switch must be used in combination with an audible and/or visual alarm to signal any loss of system pressure. The Low Pressure Warning Switch is explained in the Operating Instructions (Form No. 81-620-021). **Do not disconnect Low Pressure Warning Switch.**
3. All lines, fittings and adjacent areas must be cleaned of dirt or road residue before any lines or fittings are disconnected. Special care must be taken so dirt and road residue are not allowed to enter hydraulic brake system. This may contaminate the system and interfere with proper operation of brakes and MICO locking devices.
4. Follow procedures outlined in Vehicle Manufacturer's Service Manual or SAE Standards when making new connections or adding to existing brake systems. Use only steel brake tubing conforming to SAE specifications.
5. For brake fluid models, use only brake fluid conforming to latest SAE or DOT Standards. Improper or contaminated brake fluid may cause gummy deposits and softening and swelling of other rubber seals in the entire brake system. Such a condition must be corrected immediately.
6. Do not use sealants, tapes, teflon or cement compounds on any connections or fittings. These sealants or compounds can contaminate the hydraulic brake system and interfere with the operation of brake components or MICO locking device.
7. All fittings and connections must be in good condition and tightened to proper torque values as specified in the Installation and Service Instructions.
8. Separate models of MICO locking devices are available for brake fluid and for mineral based hydraulic oil. Select model to conform with the type of fluid in system.
9. Brake hoses, brake lines, MICO locking device, brake components, cylinders, and all fittings must be routinely inspected for leaks, damage or wear. Adequate fluid levels must be maintained. In the event of any loss of fluid, brake system must be carefully inspected for leaks.
10. After installation, bleed system according to vehicle manufacturer's recommendations.
11. Follow INSPECTIONS and TESTS section as outlined in the Operating Instructions.
12. The self-adhesive warning label accompanying each MICO locking device must be affixed in cab in view of operator.
13. The Operating Instructions must be placed in cab of vehicle in a place available to operator.

MICO is a registered trademark of MICO, Incorporated. MICO is registered in the U.S. Patent and Trademark Office as well as in Australia, Canada, Great Britain, Indonesia, Japan, Peoples Republic of China, and South Korea.



Innovative Braking and Controls Worldwide

### **MICO, Incorporated**

1911 Lee Boulevard / North Mankato, MN U.S.A. 56003-2507  
Tel: 507.625.6426 Fax: 507.625.3212

## ⚠ WARNING

The MICO Brake Lock is not to be used if four wheel lock-up is desired or in 3 or 4-channel anti-lock brake systems. For these applications we recommend using the MICO Duallock or MICO 691 Brake Lock System. (See Form No. 80-950-152). The MICO Brake Lock must be installed in the primary line from the tandem master cylinder when used in a dual brake system, Figure 4.

## MOUNTING BRAKE LOCK

Tubing is not supplied because of the variation in each installation. Install tubing using shortest and most protected route. Use same size tubing when replacing a line, unless otherwise specified.

Thoroughly inspect port threads for any foreign material after removing vinyl plugs.

## NOTE

The included low pressure warning switch must be installed. Fittings are provided for attaching the pressure switch directly to the brake lock on the end opposite the inlet port.

Mount the brake lock on the frame near the brake line using an existing hole in the frame if possible. Many times a line supporting bracket will be located in this area. This bracket may be removed and the lock mounted in its place. The brake lock will then support the lines.

## NOTE

Good electrical ground is needed between the brake lock mounting bracket and vehicle chassis. If necessary, scrape the paint off vehicle frame where the brake lock is mounted.

After installation, the brake lock may contain air. Air in the brake lock will cause an ineffective and perhaps inoperative brake system. Bleed the brake system of air.

## MOUNTING TOGGLE SWITCH AND DASH PLATE

The switch and plate are typically mounted to the dash. The toggle switch requires a 1/2 inch diameter hole.

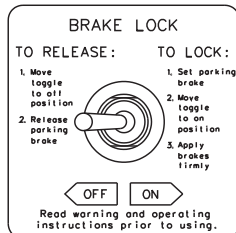

FIGURE 1

## CONNECTING BRAKE LINES

(Refer to Figures 2 through 4)

## ⚠ WARNING

The MICO Brake Lock must be installed between last hydraulic component in supply line and wheels.

## ⚠ CAUTION

When installing adaptor fittings and tube nuts in the brake lock, always grip the lock on hex nut, fitting or hex surface nearest the fitting being tightened. Never grip onto the opposite end of the brake lock. Failure to follow this procedure may result in damage to the brake lock housing.

The line from pressure source side must be installed in the end of the brake lock stamped INLET and the line to the wheels must be installed in the low pressure warning switch end of the brake lock.

## TORQUE SPECIFICATIONS

All hydraulic line connections must be torqued to specifications listed below and be free of leakage.

### Thread Size

3/8-24UNF  
7/16-24UNF  
1/2-20UNF  
9/16-18UNF

### Torque

10.8-20.3 N·m (8-15 lb-ft)  
16.3-23.0 N·m (12-17 lb-ft)  
16.3-23.0 N·m (12-17 lb-ft)  
20.3-33.9 N·m (15-25 lb-ft)

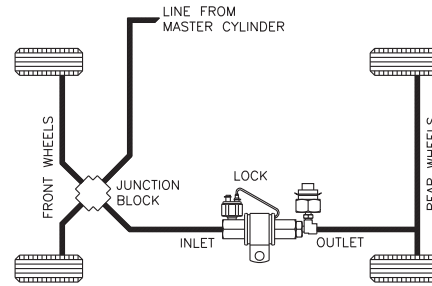

Single System with Firewall Mounted Booster

FIGURE 2

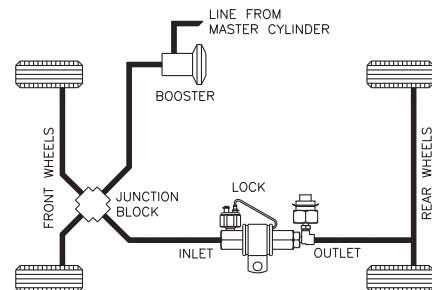

Single System with Remote Mounted Booster

FIGURE 3

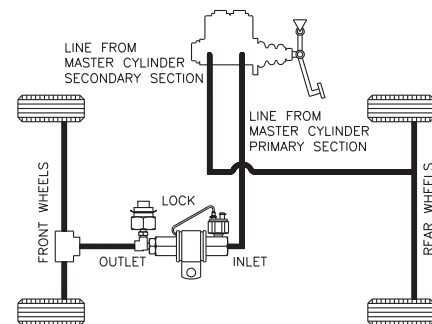

Dual System

FIGURE 4

## WIRING BRAKE LOCK

(Refer to Figures 5, 6 or 7)

1. After the brake lock is installed, make wiring connections as shown in Figures 5, 6 or 7.
2. Bleed air from the brake system and test the audible and visual warning devices to be sure they are functioning properly.

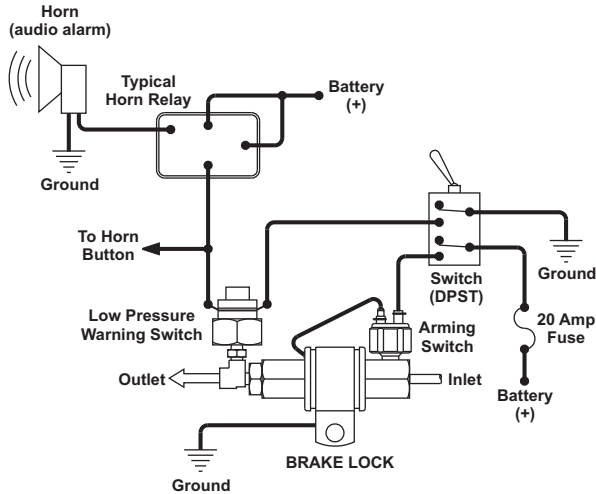

**FIGURE 5**

(vehicle horn as audio alarm)

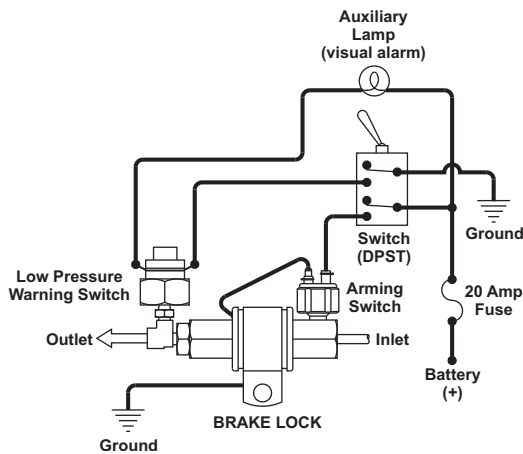

**FIGURE 6**

(auxiliary lamp as visual alarm)

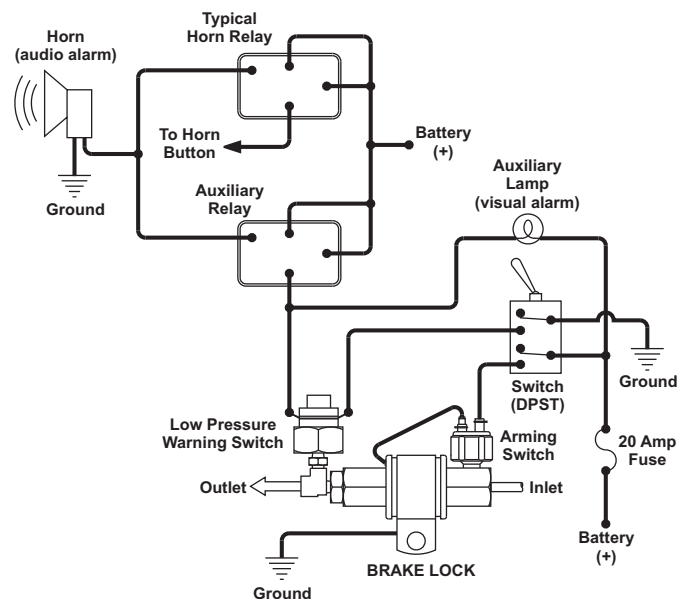

**FIGURE 7**

(audio and visual alarm)

## NOTE

When wiring an auxiliary lamp as a visual alarm, Figure 6, MICO recommends an incandescent lamp. Using a LED for visual alarm may not draw sufficient electrical current to keep the low pressure warning switch contacts functioning properly.

## Replacement Low Pressure Warning Switch Kits

Model Number	Kit Number
02-620-009 (BF)	02-600-017
02-620-172 (HO)	02-600-030
02-620-173 (BF)	02-600-017

BF - DOT 3, 4, 5 and 5.1 brake fluid  
HO - mineral base hydraulic oil

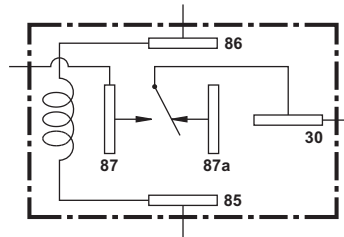

Typical Horn Relay

## BLEEDING

See General Guidelines Sheet (Form No. 81-600-001) for Bleeding Guidelines.

The hydraulic brake system must be bled whenever any line has been disconnected. There are two methods of bleeding hydraulic systems, pressure bleeding and manual bleeding. Both methods are acceptable and adequate but pressure bleeding is recommended if the equipment is available. Follow bleeding procedure and instructions as specified by vehicle manufacturer.

## CAUTION

Use only Brake Fluid SAE J1703 or DOT Brake Fluid specified by vehicle manufacturer. Never reuse brake fluid that has been drained from vehicle.

## CAUTION

Before moving the vehicle, a firm pedal must be achieved when the brake lock is in the full release position. If a firm pedal is not achieved, repeat bleeding procedures until a firm pedal is achieved. Make several brake applications with vehicle stationary and check fittings for leaks. Tighten fittings to correct any leaks that occur.

## TROUBLE SHOOTING GUIDE

The brake lock is not field serviceable - do not disassemble. If the brake lock becomes inoperable return it to MICO, Inc. for service or replacement.

PROBLEM	POSSIBLE CAUSE	RECOMMENDED SERVICE
Brake lock will not apply	*Malfunctioning toggle switch	Move toggle switch to ON position and test incoming terminal on brake lock arming switch with test lamp. If lamp lights, toggle switch is working properly.
	*Malfunctioning arming switch	If toggle switch is working properly, move toggle switch to ON position and test other terminal on arming switch with test lamp. If lamp does not light when brake pedal is depressed, replace arming switch with a new one.
	*Inadequate ground or inoperable brake lock	If toggle switch and arming switch are working properly, move toggle switch to ON position, then short across arming switch terminals. If there is no clicking sound, check for good ground to valve body. If there is still no clicking sound, replace the brake lock.
System locked up and brakes will not release	Excessive pressure locked up	Loosening a bleeder screw at the service brakes will correct this condition. If this condition repeats, we recommend installing a gauge to determine locked up pressure.
	Toggle switch internally shorted or sticking	Check toggle switch to see that it is in OFF position. If switch appears to be OFF, disconnect wire lead at switch and reapply brake pedal. If brakes release, the toggle switch is internally shorted or sticking.
	Master cylinder or booster malfunction	Trouble may be somewhere other than the brake lock. After brake pedal has been applied firmly and lock does not release then bleed off at INLET. If the brakes release, the cause of the non-release is not in the brake lock but in the master cylinder and/or booster. If disconnecting line at INLET side of brake lock does not release brakes, then disconnect at OUTLET end brake lock. If brakes release, replace the brake lock.
	Lock installed incorrectly between master cylinder and booster	Replumb lock so it is installed between vehicle brake and last hydraulic component in supply line.
Brake lock will not hold pressure	Leaking conditions in tubing and/or fittings	Check all tubing and fittings in brake system, tighten or replace where required.
	Leak in brake system	Check for fluid leaks. Repair or replace components as necessary.
	Leak within the brake lock	Replace the brake lock.
Visual and/or audible alarm (low pressure warning switch) operates inadvertently or will not shut off	Locked up pressure leaking off	See problems and conditions under heading "Brake system will not hold pressure".
	Wiring improperly installed or short in wires	Check installation to conform with installation diagram (Figures 5, 6 and 7). Check for shorted wiring.
	Insufficient brake system pressure for low pressure warning switch to open	Contact MICO, Incorporated.
Spongy or soft brake pedal	Air in the brake system	Follow proper bleeding procedures. Use pressure bleeding when available.
	Slow leak in the brake system	Check service brake system for leaks. Tighten or replace fittings and components as necessary.

**\*None of these conditions affect release of the brake lock after application. The brake lock cannot be applied if any of these conditions occur.**

MICO could not possibly know of and give advice with respect to all conceivable applications in which this product may be used and the possible hazards and/or results of each application. MICO has not undertaken any such wide evaluation. Therefore, anyone who uses an application which is not recommended by the manufacturer, first must completely satisfy himself that a danger will not be created by the application selected, or by the particular model of our product that is selected for the application.

MICO has made every attempt to present accurate information in catalogs, brochures and other printed material. MICO can accept no responsibility for errors from unintentional oversights that may exist. Due to a continuous program of product improvement, materials, specifications, and product documentation are subject to change without notice or obligation.