

LEVER LOCK

Installation and Service Instructions

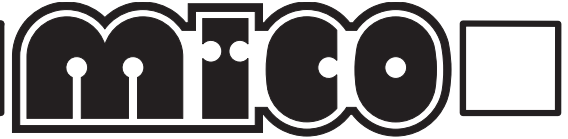

BRAKE FLUID MODEL NUMBERS

02-640-123
02-640-125
03-640-131

MINERAL BASED HYDRAULIC OIL MODEL NUMBERS

02-640-124
02-640-126
03-640-134

READ GENERAL INSTALLATION GUIDELINES SHEET (81-600-001) BEFORE PROCEEDING

⚠ WARNING

1. All MICO locking devices are **supplemental** safety equipment which provide additional brake holding action **when used with existing vehicle parking brake**.
2. The Low Pressure Warning Switch must be used in combination with an audible or visual alarm to signal any loss of system pressure. The Low Pressure Warning Switch is explained in the Operating Instructions (Form No. 81-640-033). **Do not disconnect Low Pressure Warning Switch.**
3. All lines, fittings and adjacent areas must be cleaned of dirt or road residue before any lines or fittings are disconnected. Special care must be taken so dirt and road residue are not allowed to enter hydraulic brake system. This can contaminate the system and interfere with proper operation of brakes and MICO locking devices.
4. Follow procedures outlined in Vehicle Manufacturer's Service Manual or SAE Standards when making new connections or adding to existing brake systems. Use only steel brake tubing conforming to SAE specifications.
5. Use only brake fluid conforming to latest SAE or DOT Standards. Improper or contaminated brake fluid may cause gummy deposits and softening and swelling of other rubber seals in the entire brake system. Such a condition must be corrected immediately.
6. Do not use sealants, tapes, teflon or cement compounds on any connections or fittings. These sealants or compounds can contaminate the hydraulic brake system and interfere with the operation of brake components or MICO locking device.
7. All fittings and connections must be in good condition and tightened to proper torque values as specified in the Installation and Service Instructions.
8. Separate models of MICO locking devices are available for brake fluid and for mineral based hydraulic oil. Select a model that conforms with the type of fluid in system.
9. Brake hoses, brake lines, MICO locking device, brake components, cylinders, and all fittings must be routinely inspected for leaks, damage or wear. Adequate fluid levels must be maintained. In the event of any loss of fluid, the brake system must be carefully inspected for leaks.
10. After installation, bleed system according to vehicle manufacturer's recommendations.
11. Follow **INSPECTIONS** and **TESTS** section as outlined in the Operating Instructions.
12. The self-adhesive warning label accompanying each MICO locking device must be affixed in cab in view of operator.
13. The Operating Instructions must be placed in cab of vehicle in a place available to operator.

MICO could not possibly know of and give advice with respect to all conceivable applications in which this product may be used and the possible hazards and/or results of each application. MICO has not undertaken any such wide evaluation. Therefore, anyone who uses an application which is not recommended by the manufacturer, first must completely satisfy himself that a danger will not be created by the application selected, or by the particular model of our product that is selected for the application.

MICO has made every attempt to present accurate information in catalogs, brochures and other printed material. MICO can accept no responsibility for errors from unintentional oversights that may exist. Due to a continuous program of product improvement, materials, specifications, and product documentation are subject to change without notice or obligation.

MICO is a registered trademark of MICO, Inc. MICO is registered in the U.S. Patent and Trademark Office as well as in Australia, Indonesia, Japan, Peoples Republic of China, South Korea, and the European Community.



Innovative Braking and Controls Worldwide

MICO, Incorporated

1911 Lee Boulevard / North Mankato, MN U.S.A. 56003-2507
Tel: +1 507 625 6426 Fax: +1 507 625 3212

MOUNTING LEVER LOCK

Locate Lever Lock for operator's convenience and allow for complete movement of lever.

The Lever Lock can be mounted under the dash lip for which a special mounting bracket is provided.

Tubing is not supplied because of the variation in each installation. Install tubing using shortest and most protected route. Use same size tubing when replacing a line, unless otherwise specified.

Thoroughly inspect port threads for any foreign material after removing vinyl plugs.

Bleeder screws provided must be used on installation. The Lever Lock will usually be the highest component in the system and may contain air. This air, if not removed, will cause an ineffective and perhaps inoperative brake system.

1. Using mounting bracket provided, mark lower dash lip with center punch and drill two 17/64 inch holes. Mount bracket using bolts, nuts and lock washers provided (Figure 1).
2. Select proper size fittings to match vehicle brake line. Install tube nut in fitting(s) and install in the lower ports of the lock body (bleeder screws occupy the upper ports). Tighten fittings as indicated in the torque specifications. Remove tube nuts.
3. Remove clevis assembly from body, leaving nut and lock washer on threads.
4. Before installing unit on bracket, be sure the jam nut is screwed back as close to body as possible and the lock washer is outboard of the nut.
5. Insert body in previously installed bracket from back. Install dash plate. Install clevis assembly. **Tighten clevis assembly until it bottoms out on body.**
6. Before tightening jam nut, be sure dash plate is straight and the word TOP, stamped on clevis, is at the top and the lever is down. Position bleeder screws as close to upright as possible and torque 9.5-10.9 N·m (84-96 lb·in) (Figure 1). Torque jam nut with a 15/16 inch open end wrench 20.3-33.9 N·m (15-25 lb·ft).

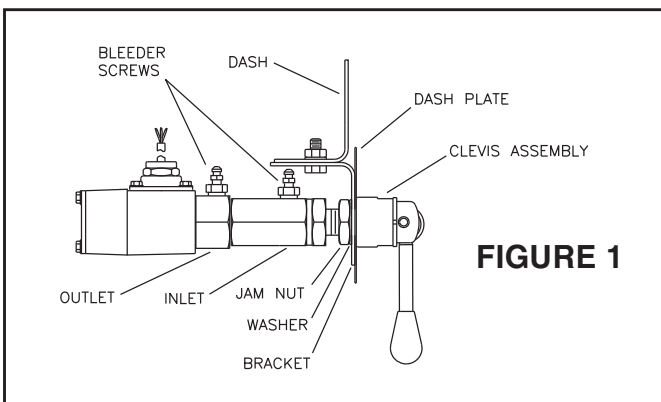

FIGURE 1

TORQUE SPECIFICATIONS

All hydraulic line connections must be torqued to specifications listed below and be free of leakage.

Thread Size	Torque
3/8-24	10.8-20.3 N·m (8-15 lb·ft)
7/16-24	16.3-23.0 N·m (12-17 lb·ft)
1/2-20	16.3-23.0 N·m (12-17 lb·ft)
9/16-18	20.3-33.9 N·m (15-25 lb·ft)

CONNECTING BRAKE LINES

⚠ WARNING

For all brake systems in use today, including anti-lock, the MICO Lever Lock must be installed between last hydraulic component in supply line and wheels.

Single System

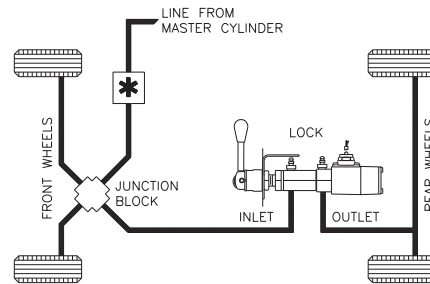

* If four-wheel lockup is desired, install lock in the line between master cylinder and junction block.

FIREWALL MOUNTED BOOSTER

FIGURE 2

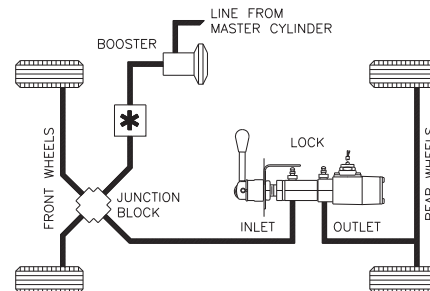

* If four-wheel lockup is desired, install lock in the line between master cylinder and junction block.

REMOTE MOUNTED BOOSTER

FIGURE 3

1. Disconnect line from rear wheels at junction block.
2. Install new line from the opened port of junction block to the INLET port of Lever Lock. Install bleeder screws in upper ports of Lever Lock.
3. Install new line in OUTLET port of Lever Lock and connect to line from rear wheels using tube union.

NOTE

The lever lock can only be used to lock one wheel in a 4-Channel Anti-Lock System and should not be used.

Dual System

Warning/Proportioning Valve and Rear Anti-Lock Control Valve may not be used in some Dual Systems.

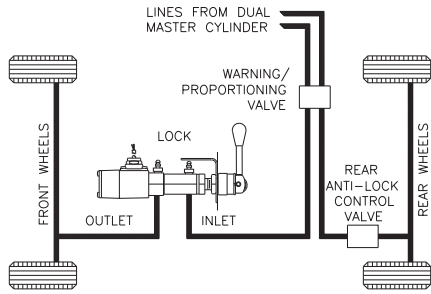

FIREWALL MOUNTED BOOSTER

FIGURE 4

3-Channel Anti-Lock System (ABS)

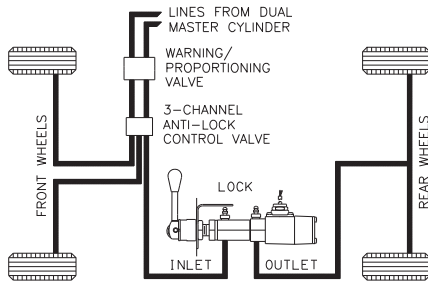

REMOTE MOUNTED BOOSTER

FIGURE 5

1. Disconnect line from wheels at the warning/proportioning valve (anti-lock control valve on ABS systems).

NOTE: If there is a tube union in the line to wheels you may prefer to disconnect there.

2. Install new line from the opened port to the INLET port of Lever Lock. Install bleeder screw in upper ports of Lever Lock.
3. Install new line in OUTLET port of Lever Lock and connect to line from wheels using a tube union.

CONNECTING HORN RELAY AND LOW PRESSURE WARNING SWITCH (See Figure 6)

CAUTION

If the vehicle does not have an auxiliary horn relay, or it is inaccessible, you will need to install one. The auxiliary horn relay must be used when the electrical load exceeds 3 amps. Do not make connections from warning circuit directly to battery terminal; pressure switch contacts will be damaged.

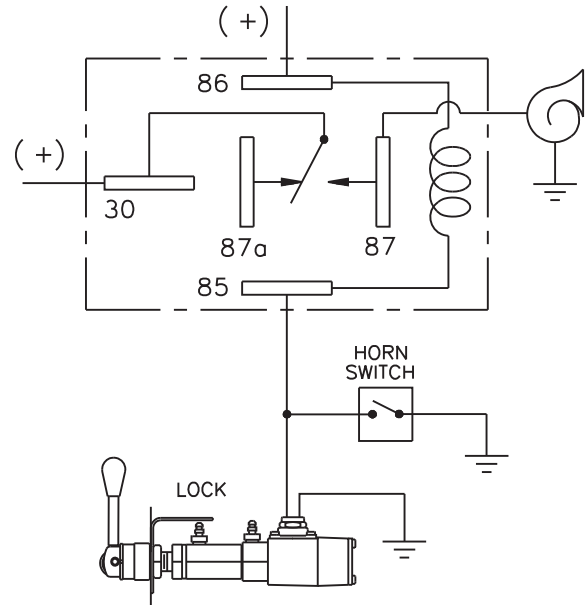

Typical Horn Relay

FIGURE 6

INSTALLATION OF CLEVIS ASSEMBLY AND PUSH ROD KIT

(See Figure 7)

NOTE

It is not necessary to remove entire unit from dash when using repair parts from kits 02-600-001 and 02-600-002.

Disassembly Procedure

1. Remove clevis assembly from unit by loosening jam nut with 15/16 inch wrench. Jam nut is located behind mounting bracket (Figure 1).
2. Remove push rod assembly from body. (Figure 7)

Assembly Procedure

1. Clean all parts thoroughly before assembling.
2. Lubricate new push rod assembly with clean type fluid used in system and install in body with nylon tip protruding.
3. Before installing clevis assembly, be sure that jam nut is screwed back to body as far as possible and that the lock washer is outboard of nut (Figure 1).
4. Install dash plate over protruding threads.
5. Screw on clevis assembly until it bottoms out on body.
6. Before tightening jam nut, be sure dash plate is straight and the word TOP, stamped on the clevis, is at the top and the lever is down. Position bleeder screws as close to upright as possible and torque 9.5-10.9 N·m (84-97 lb·in). Torque jam nut with a 15/16 inch open end wrench 20.3-33.9 N·m (15-25 lb·ft).
7. Bleed system of air (see BLEEDING section on page 4). Tighten fittings if leaks occur (see TORQUE SPECIFICATIONS on page 2). Make several applications to be sure that lock is functioning properly.

FIGURE 7

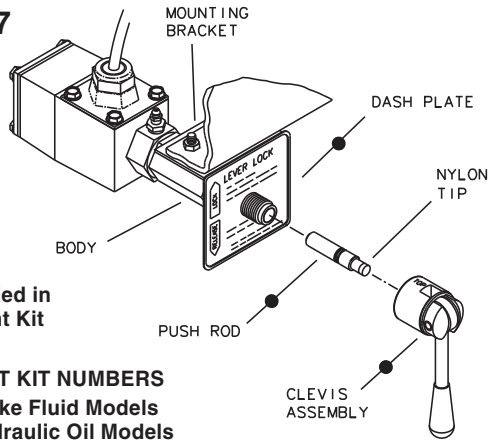

● Items included in Replacement Kit

REPLACEMENT KIT NUMBERS
 02-600-001 Brake Fluid Models
 02-600-002 Hydraulic Oil Models

BLEEDING

See General Guidelines Sheet (Form No. 81-600-001) for Bleeding Guidelines.

The hydraulic brake system must be bled whenever any line has been disconnected. There are two methods of bleeding hydraulic systems, pressure bleeding and

manual bleeding. Both methods are acceptable and adequate but pressure bleeding is recommended if the equipment is available. Follow bleeding procedure and instructions as specified by vehicle manufacturer.

⚠ CAUTION

Use only Brake Fluid SAE J1703 or DOT 3 or 4 Brake Fluid or brake fluid specified by vehicle manufacturer. Never reuse brake fluid that has been drained from the system.

⚠ CAUTION

Before moving vehicle, a firm pedal must be achieved when Lever Lock is in full release position. If a firm pedal is not achieved, repeat bleeding procedure for Lever Lock and brake system until a firm pedal is achieved. Make several brake applications with vehicle stationary and check fittings for leaks.

TROUBLE SHOOTING GUIDE

Clevis assembly and push rod are supplied in Replacement Kit listed above (see Figure 7). Lock body and internal components are not available for field service. If Lever Lock is damaged by contaminants or impaired in any way return to MICO, Incorporated for reconditioning or replacement and service other components accordingly.

PROBLEM	POSSIBLE CAUSE	RECOMMENDED SERVICE
System locked up and brakes will not release	Master cylinder or booster malfunction	Bleed at booster. If brakes release, problem is booster. Replace booster.
	Lock installed incorrectly between master cylinder and booster	Replumb lock so it is installed between vehicle brake and last hydraulic component in supply line.
	Clevis assembly not bottomed out on body resulting in excessive push rod to cam clearance	Screw on clevis assembly until it bottoms out on body.
	Wear tip worn excessively or broken off	Replace lock push rod, following instructions on page 3. Rebleed brake system.
	Clevis assembly worn excessively	Replace clevis assembly.
Brake system will not hold pressure	Leaking conditions in tubing and/or fittings	Check all tubing and fittings in brake system. Tighten or replace where required.
	Leak in wheel cylinder or caliper	Check for moist condition. If moist condition exists replace or rebuild.
	Leak in lock valve	Replace lock.
Low Pressure Warning Switch operates inadvertently or will not shut off	Locked up pressure leaking off	See problems and conditions under heading "Brake system will not hold pressure".
	Wiring improperly installed or short in wires	Check installation to conform with installation diagram. Check for shorted wiring.
Spongy or soft brake pedal	Air in system, improper bleeding at time of installation	Follow good bleeding practices. Use pressure bleeder when available.
	Slow leak in system	Check fittings and wheel cylinder for leaks. Tighten or replace fittings. Replace worn or damaged wheel cylinder.