



2010

Brake Lock Application Guide

Multi-Stop
Delivery Vehicles



Many commercial vehicles, as well as recreational and off-highway vehicles, require that they remain stationary while performing the functions for which they were designed. Some of these vehicles are found in the utility, cable television, vehicle recovery, multi-stop, transit, refuse recycling, sanitation ground support, and lawn care industries.



In-Plant and
Warehouse Equipment

In addition to a well maintained and adjusted mechanical parking brake, experience has shown that in many uses, additional supplemental holding is necessary. This can be done in the form of wheel chocks, outriggers, or other means to keep all wheels that are in contact with the ground from moving.

Service and
Utility Vehicles



Hydraulic Brake Locks

MICO Locks are for supplemental parking and are to be used in conjunction with a vehicle's mechanical parking brake. They perform as an operational holding brake only and are not intended to be used for prolonged parking. All MICO Brake Locks include low pressure warning switch(s) for added safety.



Waste & Recycling
Vehicles

Recreation
Vehicles



Several types of Brake Locks are available for use on single, dual, split, or anti-lock brake systems. The Brake Lock you select will depend on the type of brake system on your vehicle.



Airport Support
Vehicles

Brake Lock Product Line

691 Brake Lock System

(Patent Number 5,505,528)

MICO 691 Brake Lock Systems lock hydraulic pressure in the service brakes to supplement the vehicle's mechanical parking brake and provide extra holding in heavy-duty and high frequency applications. These systems also function as an interlock to apply pressure to the service brakes when other vehicle mounted equipment is being used.

The 691 System consists of a small electrohydraulic pump, remote mounted actuator (single and/or dual), electronic control module, and a small dash mounted user interface. The operator simply activates a switch and the 691 System automatically applies, monitors, and maintains brake-locking pressure.

A 691 Brake Lock will significantly enhance vehicle holding capability while not interfering with normal service brake function.

MODELS:

02-691-101 - Single Brake Lock System - (BF) *

02-691-109 - Single Brake Lock System - (BF) **

02-691-201 - Dual Brake Lock System - (BF) *

02-691-209 - Dual Brake Lock System - (BF) **

02-691-303 - 3 - Channel Anti-Lock Brake Lock System - (BF) *

02-691-305 - 3 - Channel Anti-Lock Brake Lock System - (BF) **

02-691-403 - 4 - Channel Anti-Lock Brake Lock System - (BF) *

(BF) = Brake Fluid * Over 19,000 GVW ** 19,000 GVW and under

NOTE: 691 System uses silicone fluid.

See chart with 691 Models and Sub-Components on page 11.



User Interface



Control Module



Power Unit



Single Actuator



Dual Actuator



Wire Harness

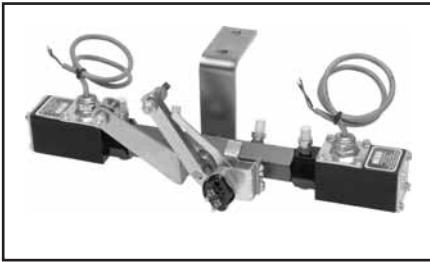

Duallock

Duallocks are designed to supplement a vehicle's standard parking brake by utilizing the hydraulic service brakes of a vehicle equipped with a dual or split braking system. Duallocks can provide 4-wheel lockup for hydraulic dual brake systems or rear wheel ABS, as well as, 2-wheel lockup for hydraulic 3 and 4 channel ABS. Each Duallock includes two low pressure warning switches.

MODELS:

02-640-169 - Cable operated - 3/16" & 1/4" fittings - in line mount - includes 10 ft. cable - (BF)

02-640-202 - Cable operated - 3/16" & 1/4" fittings - in line mount - includes 10 ft. cable - (HO)

(BF) = Brake Fluid

(HO) = Hydraulic Oil



Lever Lock

Lever Locks are designed to supplement a vehicle's standard parking brake by utilizing the hydraulic service brakes. Lever Locks are manually operated one-way check valves which lock fluid under pressure in the selected brakes. Hand operation leaves the operator's feet free for clutch and throttle pedal operation. Each Lever Lock includes a low pressure warning switch.

MODELS:

02-640-125 - Lever Lock - 3/16" & 1/4" fittings - (BF)

02-640-126 - Lever Lock - 3/16" & 1/4" fittings - (HO)

(BF) = Brake Fluid

(HO) = Hydraulic Oil



Twist Lock

Twist Locks are functionally the same as lever locks. The differences being a Twist Lock has a rotary action handle and the push rod is sealed and lubricated with silicone grease for tough environmental applications. Each Twist Lock includes a low pressure warning switch.

MODELS:

03-640-075 - Twist Lock - 3/16" & 1/4" fittings - (BF)

03-640-076 - Twist Lock - 3/16" & 1/4" fittings - (HO)

(BF) = Brake Fluid

(HO) = Hydraulic Oil



Cable Lock

Cable Locks are functionally the same as lever locks and twist locks. The difference being a Cable Lock is cable operated for remote mountings when space under the dash is limited. Each Cable Lock includes a low pressure warning switch.

MODEL:

02-640-023 - Cable Lock - 3/16" & 1/4" fittings - includes 10 ft. cable - (BF)

02-640-122 - Cable Lock - includes 10 ft. cable - (HO)

(BF) = Brake Fluid

(HO) = Hydraulic Oil

Different Brake Systems

Typical hydraulic braking systems in use today vary depending on manufacturer and size of vehicle. For instance, a vehicle equipped with a single system may have a firewall mounted booster or possibly a frame mounted remote booster. The same holds true for the dual and split systems. The rear wheel anti-lock system is a dual brake system with an anti-lock valve installed. All-wheel anti-lock systems are defined as 3-channel or

4-channel systems (Check the number of outlet lines from the anti-lock control valve). To be absolutely sure which braking system your vehicle is equipped with, check it. Look for identifying features such as dual flex lines at rear axle or front wheels, number of master cylinder lines, anti-lock valve(s), etc. Then, compare with circuits shown here.

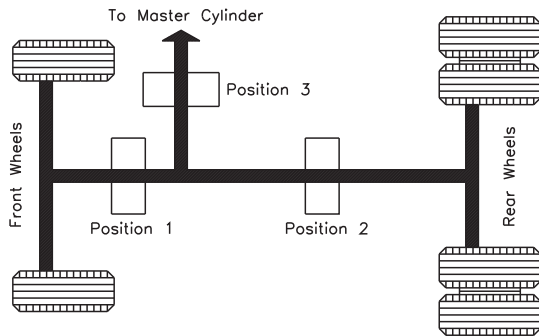

FIGURE 1

TYPICAL SINGLE SYSTEM

One single hydraulic system serving both front and rear brakes.

Identifying Feature:

1. One line from master cylinder.

Lock Position:

- (1) Front axle (2) Rear axle (3) 4-wheel

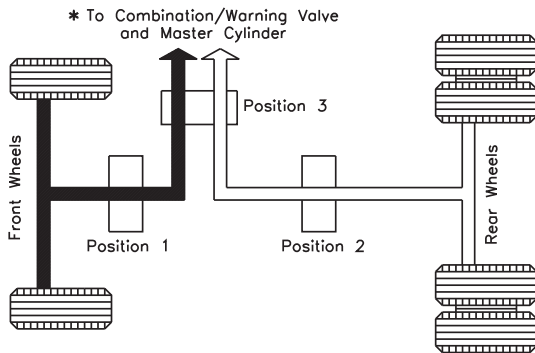

FIGURE 2

TYPICAL DUAL SYSTEM (Vertical Split)

Two independent braking systems. One system leads to the front brakes and the other system to the rear brakes.

Identifying Features:

1. Two lines from master cylinder.
2. Combination valve (used on some models).

Lock Position:

- (1) Front axle (2) Rear axle* (3) 4-wheel

* Some imported vehicles use two separate air boosted master cylinders.

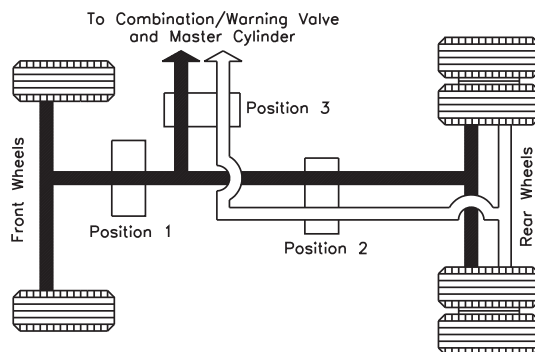

FIGURE 3

TYPICAL SPLIT SYSTEM (1 1/2 x 1/2)

Two independent braking systems. One system leads to the front and the rear brakes and the other system leads only to the rear brakes.

Identifying Features:

1. Two lines from master cylinder.
2. Single hose to each front wheel.
3. Two hoses to rear axle.

Lock Position:

- (1) Front axle (2) Rear axle (3) 4-wheel

CAUTION: If position 2 or 3 is used, both halves of system must be locked.

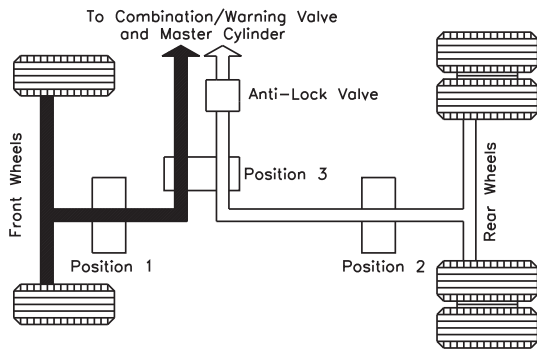

FIGURE 4

**TYPICAL REAR WHEEL ANTI-LOCK SYSTEM
(Dual Vertical Split)**

Two independent braking systems. One system leads to the front brakes and the other system to the rear brakes.

Identifying Features:

1. Two lines from master cylinder.
2. Anti-lock control valve between master cylinder and rear wheels.

Lock Position:

- (1) Front axle (2) Rear axle (3) 4-wheel

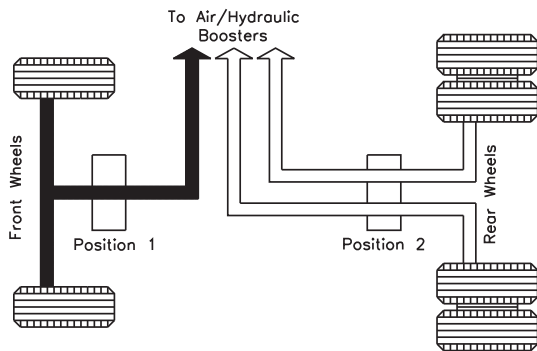

FIGURE 5

**IMPORTED TRUCK 3-CHANNEL
ALL-WHEEL ANTI-LOCK SYSTEM**

Provides braking control by way of independent anti-lock channels for each rear wheel and a third channel for the front wheels.

Identifying Features:

1. Three separate air/hydraulic brake boosters.
2. One line to front brakes.
3. Separate lines to each rear wheel.

Lock Position:

- (1) Front axle (2) Rear axle (1 & 2) 4-wheel

NOTE: The anti-lock functions on air booster system, not the hydraulic side.

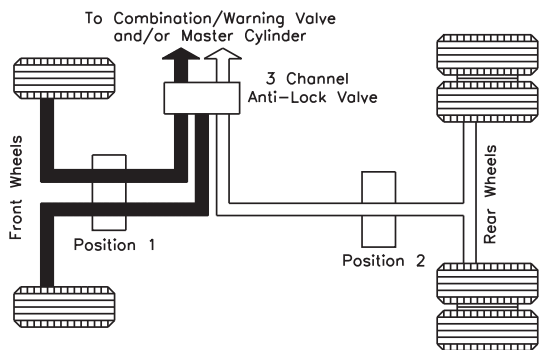

FIGURE 6

**TYPICAL 3-CHANNEL ALL-WHEEL
ANTI-LOCK SYSTEM**

Provides braking control by way of independent anti-lock channels for each front wheel and a third channel for both rear wheels.

Identifying Features:

1. Two lines from master cylinder to anti-lock valve(s).
2. One line from anti-lock valve to rear brakes.
3. Separate lines from anti-lock valve to each front wheel.

Lock Position:

- (1) Front axle (2) Rear axle (1 & 2) 4-wheel

NOTE: Some 3-channel anti-lock brake systems use two separate anti-lock valve assemblies.

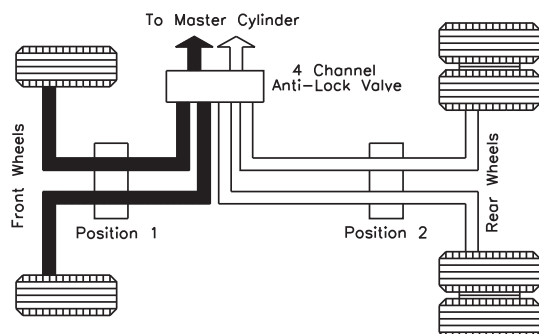

FIGURE 7

**TYPICAL 4-CHANNEL ALL-WHEEL
ANTI-LOCK SYSTEM**

Provides braking control by way of an independent channel for each front wheel and each rear wheel.

Identifying Features:

1. Two lines from master cylinder to anti-lock valve.
2. Separate lines from anti-lock valve to each of the front and rear wheels.

Lock Position:

- (1) Front axle (2) Rear axle (1 & 2) 4-wheel

NOTE: Some 4-channel anti-lock brake systems use two separate anti-lock valve assemblies.

North American Manufactured

Chevrolet - GMC

Light Duty (C/K10-30, C/K1500-3500)

Model Year	Brake System Type	Service Brakes	Miscellaneous Notes	Aerial Lift Bucket		Other Applications	
				4 Wheel	2 Wheel	4 Wheel	2 Wheel
1967-1987	Dual (Figure 2)	F-disc/R-drum	Early models had 4 wheel drum brakes.	02-691-209	02-691-109	02-691-209 02-640-169	02-691-109 02-640-125
1988-1994	Rear ABS (Figure 4)	F-disc/R-drum		02-691-209	02-691-109	02-691-209 02-640-169	02-691-109 02-640-125
1995-2010	3-channel ABS (Figure 6)	F-disc/R-drum		02-691-305	02-691-109*	02-691-305	02-691-109* 02-640-125*

3500HD (All models have Hydraulic Boost Master Cylinders)

Model Year	Brake System Type	Service Brakes	Miscellaneous Notes	4 Wheel	2 Wheel	4 Wheel	2 Wheel
1990-1992	Dual (Figure 2)	4 wheel disc	Load sensing valve at rear axle.	02-691-209	02-691-109	02-691-209 02-640-169	02-691-109 02-640-125
1993-1994	Rear ABS (Figure 4)	4 wheel disc	Load sensing valve at rear axle.	02-691-209	02-691-109	02-691-209 02-640-169	02-691-109 02-640-125
1995-2002	3-channel ABS (Figure 6)	4 wheel disc	No load sensing valve at rear axle.	02-691-305	02-691-109*	02-691-305	02-691-109* 02-640-125*

NOTE: Brakes on 2011 model year GM class 1-3 Light Duty available Spring of 2010 expected to be unchanged from 2010 models.

Medium Duty (C50-C65, Kodiak & TopKick, C4500-C7500 Conventional Cab, T5500-T7500 Tilt Cab - Also Isuzu H-Series Conventional Cab)

Model Year	Brake System Type	Service Brakes	Miscellaneous Notes	4 Wheel	2 Wheel	4 Wheel	2 Wheel
1970-mid 1980s	Single (Figure 1)	Drum	Hydrovac	02-691-101	02-691-101	02-691-101 02-640-023	02-691-101 02-640-023
1970-mid 1980s	Dual (Figure 2)	Drum	Hydrovac(s)	02-691-201	02-691-101	02-691-201 02-640-169	02-691-101 02-640-023
1970-mid 1980s	1 1/2 x 1/2 split ● (Figure 3)	Drum	● A dual brake lock is required for either rear or 4 wheel lockup.	02-691-201	02-691-201	02-691-201	02-691-201 02-640-023◆
mid '80s-1996	Dual (Figure 2)	4 wheel disc	Hydraulic Boost Master Cylinder.	02-691-201	02-691-101	02-691-201 02-640-169	02-691-101 02-640-023
1997-2009	4-channel ABS (Figure 7)	4 wheel disc	4-channel ABS standard. Option to delete was available prior to 1 Mar 99. †	02-691-403	02-691-209	02-691-403	02-691-209 02-640-169

Dodge

Light Duty (D100-D350, Ram 1500-3500)

Model Year	Brake System Type	Service Brakes	Miscellaneous Notes	4 Wheel	2 Wheel	4 Wheel	2 Wheel
mid 70's-1988	Dual (Figure 2)	F-disc/R-drum		02-691-209	02-691-109	02-691-209 02-640-169	02-691-109 02-640-125
1989-1993	Rear ABS (Figure 4)	F-disc/R-drum	Anti-lock valve location at rear axle makes it difficult to install lock downstream from anti-lock valve. Single locks should go on front axle.	02-691-209	02-691-109	02-691-209 02-640-169	02-691-109 02-640-125
1994-1998	Rear ABS (Figure 4)	F-disc/R-drum	3-channel ABS optional. (Figure 6)	02-691-209▲	02-691-109*	02-691-209▲	02-691-109*
1999-2010	3-channel ABS (Figure 6)	F-disc/R-drum 4 wheel disc on D2500-D3500 in 2001-2005 MY 4 wheel disc all models 2006-2010 MY	3-channel ABS standard on 2500-3500; optional on 1500 in 2001-2008 MY. 4-channel ABS standard on 1500 in 2009-2010 MY.	02-691-305	02-691-109*	02-691-305	02-691-109* 02-640-125*

† With 4-channel ABS deleted, brake system type is Dual (Figure 2)

NOTE: Hydrovac = Frame mount vacuum booster

Hydraulic Boost Master Cylinder = Master cylinder driven by hydraulic booster powered by steering pump

■ Best Choice ◆ Front wheel lockup only ▲ On 3-channel ABS systems use 02-691-305 *Rear wheel lockup only on 3-channel ABS

MY Model Year

691 Installation Kits for GM C4500/5500	
Installation Kits include all major components for high quality, consistent installations.	
Locking front wheels only: 02-603-006 Installation Kit / Use with 02-691-209 Dual 691 Lock	
Locking rear wheels only: 02-603-007 Installation Kit / Use with 02-691-209 Dual 691 Lock	
Locking all four wheels: 02-603-002 Installation Kit / Use with 02-691-403 4-Channel 691 Lock	

North American Manufactured

Ford

Vehicle Application

Light Duty (E150-E250, F150-F250) below 8600 lb GVW

Model Year	Brake System Type	Service Brakes	Miscellaneous Notes	Aerial Lift Bucket		Other Applications	
				4 Wheel	2 Wheel	4 Wheel	2 Wheel
1967-1986	Dual (Figure 2)	F-disc/R-drum	Early models had 4 wheel drum brakes.	02-691-209	02-691-109	02-691-209 02-640-169	02-691-109 02-640-125
1987-1996	Rear ABS (Figure 4)	F-disc/R-drum		02-691-209	02-691-109	02-691-209 02-640-169	02-691-109 02-640-125
1997-2003	Rear ABS (Figure 4)	F-disc/R-drum	3-channel ABS optional. (Figure 6)	02-691-209▲	02-691-109*	02-691-209▲ 02-640-169▲	02-691-109* 02-640-125*
2004-2009	3-channel ABS (Figure 6)	4 wheel disc		02-691-305	02-691-109*	02-691-305 02-640-169	02-691-109* 02-640-125*
2010	4-channel ABS (Figure 7)	4 wheel disc		02-691-403	02-691-209	02-691-403 02-640-169	02-640-169 02-640-125

(E250-E35, F250-F350) 8600 lb and above GVW

Model Year	Brake System Type	Service Brakes	Miscellaneous Notes	4 Wheel	2 Wheel	4 Wheel	2 Wheel
1967-1986	Dual (Figure 2)	F-disc/R-drum	Early models had 4 wheel drum brakes.	02-691-209	02-691-109	02-691-209 02-640-169	02-691-109 02-640-125
1987-1998	Rear ABS (Figure 4)	F-disc/R-drum		02-691-209	02-691-109	02-691-209 02-640-169	02-691-109 02-640-125

"Super Duty"

Model Year	Brake System Type	Service Brakes	Miscellaneous Notes	4 Wheel	2 Wheel	4 Wheel	2 Wheel
1988-1998	Dual (Figure 2)	4 wheel disc		02-691-209	02-691-109	02-691-209 02-640-169	02-691-109 02-640-125

(Super Duty E250-E350, F250-F350) Below 10,000 lb GVW, single rear wheel

Model Year	Brake System Type	Service Brakes	Miscellaneous Notes	4 Wheel	2 Wheel	4 Wheel	2 Wheel
1999-2000	Rear ABS (Figure 4)	4 wheel disc	3-channel ABS optional. (Figure 6)	02-691-209▲	02-691-109*	02-691-209▲ 02-640-169▲	02-691-109* 02-640-125*
2001-2010	3-channel ABS (Figure 6)	4 wheel disc		02-691-305	02-691-109*	02-691-305	02-691-109* 02-640-125*

NOTE: 2011 F150-F350 (available in early 2010) with single rear wheels utilize 4-channel ABS (Figure 7).

(Super Duty E350-E450, F350-F550) 10,000 lb and above GVW, dual rear wheel

Model Year	Brake System Type	Service Brakes	Miscellaneous Notes	4 Wheel	2 Wheel	4 Wheel	2 Wheel
1999-2010	3-channel ABS (Figure 6)	4 wheel disc		02-691-305	02-691-109*	02-691-305	02-691-109* 02-640-125*

Medium Duty (F650-F750), 23,000 lb and over GVW

Model Year	Brake System Type	Service Brakes	Miscellaneous Notes	4 Wheel	2 Wheel	4 Wheel	2 Wheel
2001-2010	4-channel ABS (Figure 7)	4 wheel disc		02-691-403	02-691-209	02-691-403	02-691-209 02-640-169

Medium Duty (LCF) Cab Forward 16,000-19,500 lb GVW

Model Year	Brake System Type	Service Brakes	Miscellaneous Notes	4 Wheel	2 Wheel	4 Wheel	2 Wheel
2005-2010	3-channel ABS (Figure 4)	4 wheel disc		02-691-305	02-691-109□	02-691-305	02-691-109□ 02-640-023□

Freightliner

Medium Duty (Business Class F50-F80, Business Class M2, MT35-MT55)

Model Year	Brake System Type	Service Brakes	Miscellaneous Notes	4 Wheel	2 Wheel	4 Wheel	2 Wheel
1991-1996	Dual (Figure 2)	4 wheel disc	Hydraulic Boost Master Cylinder.	02-691-201	02-691-101	02-691-201 02-640-169	02-691-101 02-640-023
1997-2010	4-channel ABS (Figure 7)	4 wheel disc	4-channel ABS standard with option to delete until 1 Mar 99.✚	02-691-403	02-691-209	02-691-403	02-691-209 02-640-169

✚ With 4-channel ABS deleted, brake system type is Dual (Figure 2)

**NOTE: Hydraulic Boost Master Cylinder = Master cylinder driven by hydraulic booster powered by steering pump
Contact MICO for information on a 691 Installation Kit for Ford F450-F550**

■ Best Choice ▲ On 3-channel ABS systems use 02-691-305 NA Not Applicable

* Rear wheel lockup only on 3-channel ABS, for front wheel only lockup use 02-691-223. □ Rear wheel lockup only

North American Manufactured

International - Navistar

Medium Duty (S1600-S1800 "Loadstar")

Model Year	Brake System Type	Service Brakes	Miscellaneous Notes	Vehicle Application			
				Aerial Lift Bucket		Other Applications	
				4 Wheel	2 Wheel	4 Wheel	2 Wheel
1970-1987	Single (Figure 1)	Drum	Vacuum/Hydraulic.	02-691-101	02-691-101	02-691-101 02-640-023	02-691-101 02-640-023
1970-1987	1 1/2 x 1/2 (Figure 3)	Drum	A dual brake lock is required for either rear or 4 wheel lockup.	02-691-201	02-691-201	02-691-201	02-691-201 02-640-023◆
1970-1987	Dual (Figure 2)	Drum	Hydrovac	02-691-201	02-691-101	02-691-201 02-640-169	02-691-101 02-640-023

Medium Duty (Series 4600-4900's)

Model Year	Brake System Type	Service Brakes	Miscellaneous Notes	4 Wheel	2 Wheel	4 Wheel	2 Wheel
1988-1998	Dual (Figure 2)	4 wheel disc	Hydraulic Boost Master Cylinder.	02-691-201	02-691-101	02-691-201 02-640-169	02-691-101 02-640-023
1999-2001	4-channel ABS (Figure 7)	4 wheel disc		02-691-403	02-691-209	02-691-403	02-691-209 02-640-169

Medium Duty ("Next Generation Vehicle - Durastar" 4100-4300)

Model Year	Brake System Type	Service Brakes	Miscellaneous Notes	4 Wheel	2 Wheel	4 Wheel	2 Wheel
2002-2010	4-channel ABS (Figure 7)	4 wheel disc		02-691-403	02-691-209	02-691-403	02-691-209 02-640-169

Medium Duty (Citystar CF500-CF600 Cab Forward 16,000-19,500 lb GVW)

Model Year	Brake System Type	Service Brakes	Miscellaneous Notes	4 Wheel	2 Wheel	4 Wheel	2 Wheel
2005-2010	3-channel ABS (Figure 5)	4 wheel disc		02-691-305	02-691-109□	02-691-305	02-691-109□ 02-640-023□

Kenworth

Medium Duty (T170-T-370)

Model Year	Brake System Type	Service Brakes	Miscellaneous Notes	4 Wheel	2 Wheel	4 Wheel	2 Wheel
2001-2010	4-channel ABS (Figure 7)	4 wheel disc		02-691-403	02-691-209	02-691-403	02-691-209 02-640-169

Peterbilt

Medium Duty (Model 325-335)

Model Year	Brake System Type	Service Brakes	Miscellaneous Notes	4 Wheel	2 Wheel	4 Wheel	2 Wheel
2001-2010	4-channel ABS (Figure 7)	4 wheel disc		02-691-403	02-691-209	02-691-403	02-691-209 02-640-169

Sterling

Medium Duty ("Bullet" CONV45-CONV55)

Model Year	Brake System Type	Service Brakes	Miscellaneous Notes	4 Wheel	2 Wheel	4 Wheel	2 Wheel
2008-2009	3-channel ABS (Figure 6)	4 wheel disc		02-691-305	02-691-109*	02-691-305	02-691-109* 02-640-125*

Medium Duty ("Actera" 5500-7500)

Model Year	Brake System Type	Service Brakes	Miscellaneous Notes	4 Wheel	2 Wheel	4 Wheel	2 Wheel
2001-2009	4-channel ABS (Figure 7)	4 wheel disc		02-691-403	02-691-209	02-691-403	02-691-209 02-640-169

Toyota

Tundra

Model Year	Brake System Type	Service Brakes	Miscellaneous Notes	4 Wheel	2 Wheel	4 Wheel	2 Wheel
2008-2010	4-channel ABS (Figure 7)	4 wheel disc		02-691-403	02-691-209	02-691-403	02-691-209 02-640-169

NOTE: Hydrovac = frame mount vacuum booster

Hydraulic Boost Master Cylinder = Master cylinder driven by hydraulic booster powered by steering pump

■ Best Choice ◆ Front wheel lockup only □ Rear wheel lockup only

Offshore Manufactured

Dodge - Freightliner Sprinter

Vehicle Application

Light Duty (Van & Cab-chassis)

Model Year	Brake System Type	Service Brakes	Miscellaneous Notes	Aerial Lift Bucket		Other Applications	
				4 Wheel	2 Wheel	4 Wheel	2 Wheel
2002-2010	4-channel ABS (Figure 7)	4 wheel disc		02-691-403	02-691-209	02-691-403	02-691-209 02-640-169

General Motors "W" Series Chev Tiltmaster - GMC Forward

Light Duty (W3500-4500) also W5500 through 1998 model year

Model Year	Brake System Type	Service Brakes	Miscellaneous Notes	4 Wheel	2 Wheel	4 Wheel	2 Wheel
1986-1998	Dual (Figure 2)	Disc/Drum-Drum	Vacuum/Hydraulic booster.	02-691-209	02-691-109	02-691-209 02-640-169	02-691-109 02-640-023
2000-2009	4-channel ABS (Figure 7)	F-disc R-drum	Vacuum/Hydraulic booster.	02-691-403	02-691-209	02-691-403	02-691-209 02-640-169

Medium Duty (W5500-W5500HD)

Model Year	Brake System Type	Service Brakes	Miscellaneous Notes	4 Wheel	2 Wheel	4 Wheel	2 Wheel
2000	3-channel ABS (Figure 5)	Disc/Drum-Drum	Air/Hydraulic boost with ABS on the air side.	02-691-303	02-691-209□	02-691-303	02-691-209□ 02-640-169□
2001-2009	4-channel ABS (Figure 7)	4 wheel disc	4-channel ABS Vac/Hyd booster. '05-'07 HD is Hyd/Hyd	02-691-403	02-691-209	02-691-403	02-691-209 02-640-169

Medium Duty (WT5500)

Model Year	Brake System Type	Service Brakes	Miscellaneous Notes	4 Wheel	2 Wheel	4 Wheel	2 Wheel
2000-2004	3-channel ABS (Figure 5)	Disc/Drum-Drum	Air/Hydraulic boost with ABS on the air side.	02-691-303	02-691-209□	02-691-303	02-691-209□ 02-640-169□

Hino

Light Duty (FA)

Model Year	Brake System Type	Service Brakes	Miscellaneous Notes	4 Wheel	2 Wheel	4 Wheel	2 Wheel
2001-2004	3-channel ABS (Figure 5)	4 wheel drum	Vacuum/Hydraulic booster.	02-691-305	02-691-209□	02-691-305	02-691-209□ 02-640-169□

Light Duty (FB)

Model Year	Brake System Type	Service Brakes	Miscellaneous Notes	4 Wheel	2 Wheel	4 Wheel	2 Wheel
2001-2004	3-channel ABS (Figure 5)	4 wheel drum	Air/Hydraulic boost with ABS on the air side.	02-691-303	02-691-209□	02-691-303	02-691-209□ 02-640-169□

Medium Duty (FD-FF)

Model Year	Brake System Type	Service Brakes	Miscellaneous Notes	4 Wheel	2 Wheel	4 Wheel	2 Wheel
2001-2004	3-channel ABS (Figure 5)	4 wheel drum	Air/Hydraulic boost with ABS on the air side.	02-691-303	02-691-209□	02-691-303	02-691-209□ 02-640-169□

Conventional Cab (145-268)

Model Year	Brake System Type	Service Brakes	Miscellaneous Notes	4 Wheel	2 Wheel	4 Wheel	2 Wheel
2005-2010	4-channel ABS (Figure 7)	4 wheel disc	Hydraulic booster.	02-691-403	02-691-209	02-691-403	02-691-209 02-640-169

Isuzu

Light Duty ("NPR", "NQR", "NRR")

Model Year	Brake System Type	Service Brakes	Miscellaneous Notes	4 Wheel	2 Wheel	4 Wheel	2 Wheel
1986-1998	Dual (Figure 2)	Disc/Drum-Drum	Vacuum/Hydraulic.	02-691-209	02-691-109	02-691-209 02-640-169	02-691-109 02-640-023
2000-2010	4-channel ABS (Figure 7)	F-disc/R-drum	Vacuum/Hydraulic.	02-691-403	02-691-209	02-691-403	02-691-209 02-640-169

Medium Duty (Isuzu "FRR")

Model Year	Brake System Type	Service Brakes	Miscellaneous Notes	4 Wheel	2 Wheel	4 Wheel	2 Wheel
1988-1998	Dual (Figure 2)	Drum	Air/Hydraulic.	02-691-209	02-691-109	02-691-209 02-640-169	02-691-109 02-640-023
2000-2004	3-channel ABS (Figure 5)	4 wheel drum	Air/Hydraulic boost with ABS on the air side.	02-691-303	02-691-209□	02-691-303	02-691-209□ 02-640-169□

NOTE: For Isuzu H-Series conventional cabs - See Chevrolet Medium duty section.

■ Best Choice

□ Rear wheel lockup only

Offshore Manufactured

Vehicle Application

Medium Duty (Isuzu "FSR", "FTR", "FVR")

Model Year	Brake System Type	Service Brakes	Miscellaneous Notes	Interlock Applications / Aerial Lift Bucket		Other Applications	
				4 Wheel	2 Wheel	4 Wheel	2 Wheel
1999-2010	4-channel ABS (Figure 7)	4-wheel disc	Hydraulic booster.	02-691-403	02-691-209	02-691-403	02-691-209 02-640-169

Mitsubishi - Fuso Light Duty (FE - FG)

Model Year	Brake System Type	Service Brakes	Miscellaneous Notes	4 Wheel	2 Wheel	4 Wheel	2 Wheel
1991-1998	Dual (Figure 2)	Drum		02-691-209	02-691-109	02-691-209 02-640-169	02-691-209 02-640-023
2000-2010	4-channel ABS (Figure 7)	F-disc/R-drum, 4-wheel disc, or 4-wheel drum	Vacuum/Hydraulic booster.	02-691-403	02-691-209	02-691-403	02-691-209 02-640-169

Medium Duty (FH)

Model Year	Brake System Type	Service Brakes	Miscellaneous Notes	4 Wheel	2 Wheel	4 Wheel	2 Wheel
1996-1998	Dual (Figure 2)	4-wheel drum	Air/Hydraulic boosters.	02-691-201	02-691-101	02-691-201 02-640-169	02-691-101 02-640-023
2000-2004	4-channel ABS (Figure 7)	4-wheel drum	Hydraulic booster.	02-691-403	02-691-209	02-691-403	02-691-209 02-640-169

Medium Duty (FK, FM-MR, FM-HR, FM260)

Model Year	Brake System Type	Service Brakes	Miscellaneous Notes	4 Wheel	2 Wheel	4 Wheel	2 Wheel
1991-1998	Dual (Figure 2)	4-wheel drum		02-691-201	02-691-101	02-691-201 02-640-169	02-691-101 02-640-023
1999-2010	3-channel ABS (Figure 5)	4-wheel drum	3-channel ABS Air/Hydraulic boost w/ABS on air side.	02-691-303	02-691-209□	02-691-303	02-691-209□ 02-640-169□

UD

Light Duty (1200-1400)

Model Year	Brake System Type	Service Brakes	Miscellaneous Notes	4 Wheel	2 Wheel	4 Wheel	2 Wheel
1990-1998	Dual (Figure 2)	4-wheel drum	Vacuum/Hydraulic booster.	02-691-209	02-691-109	02-691-209 02-640-169	02-691-109 02-640-023
2000-2010	4-channel ABS (Figure 7)	F-disc/R-drum, or 4-wheel disc	Vacuum/Hydraulic booster.	02-691-403	02-691-209	02-691-403	02-691-209 02-640-169

Medium Duty (1800CS-2600)

Model Year	Brake System Type	Service Brakes	Miscellaneous Notes	4 Wheel	2 Wheel	4 Wheel	2 Wheel
1990-1998	Dual (Figure 2)	4-wheel drum	Air/Hydraulic boosters. On trucks with optional air-rear parking brake, lock front brakes only.	02-691-201	02-691-101	02-691-201 02-640-169	02-691-101 02-640-023
1999-2010	4-channel ABS (Figure 7)	4-wheel drum	Air/Hydraulic boosters. On trucks with optional air-rear parking brake, lock front brakes only.	02-691-403	02-691-209	02-691-403	02-691-209 02-640-169

■ Best Choice □ Rear wheel lockup only.

NOTE

1999 was a transition year to ABS systems on most imported trucks. If a 1999 model does not have ABS, use the 1998 recommendations. Use the 2000 recommendations for trucks having ABS.

691 Accessories

Remote Reservoir

For use in (BF) applications

MICO offers a remote reservoir for installations where the Power Unit brass breather plug cannot be kept upright and away from dust and dirt or when visual monitoring of fluid level is desired.

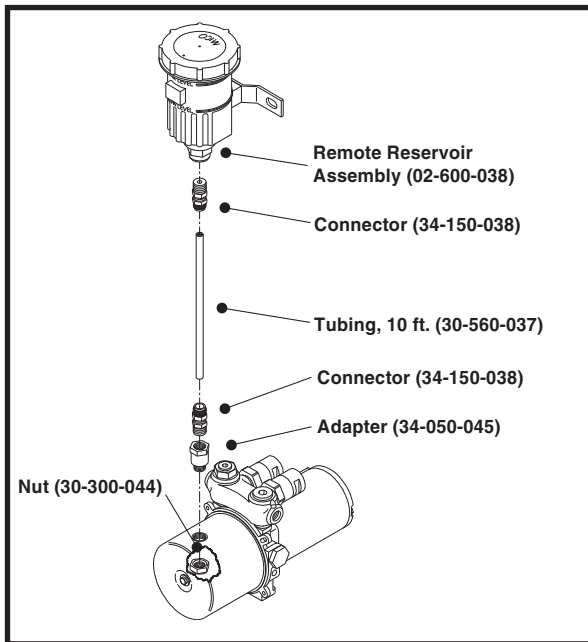

Elbow Fittings and Straight Adapters

Simplify plumbing installation using 90° or 45° elbows and straight adapters available from MICO. These fittings allow more direct routing of brake tubes with fewer bends and are handy when mounting components in close quarters.

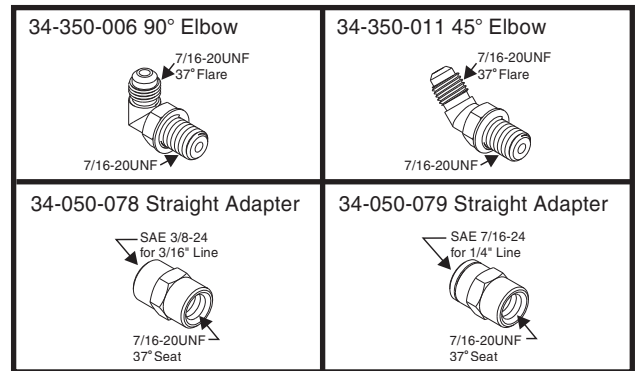

Wire Harness Extension

This 11 ft. supplemental harness simplifies wiring when 691 Control Module is mounted away from Power Unit. Contains waterproof adapters for quick connection of Control Module and Power Unit leads. Part number 32-820-022.

691 Models and Sub-Components

System Model Number	Description	Power Unit	Control Module	Actuator	User Interface	Main Wire Harness
02-691-101	Single (1 3/4 in. bore)	20-410-014	32-585-006	20-460-013	32-585-007	32-820-021
02-691-109	Single (1 1/4 in. bore)	20-410-014	32-585-006	20-460-018	32-585-007	32-820-021
02-691-201	Dual (1 3/4 in. bore)	20-410-014	32-585-006	20-460-012	32-585-007	32-820-021
02-691-209	Dual (1 1/4 in. bore)	20-410-014	32-585-006	20-460-017	32-585-007	32-820-021
** 02-691-223	Dual (1 1/4 in. bore)	20-410-014	32-585-006	20-460-018 (two)	32-585-007	32-820-021
*** 02-691-303	3-Channel	20-410-014	32-585-006	20-460-013 (one) 20-460-017 (one)	32-585-007	32-820-021
**** 02-691-305	3-Channel	20-410-014	32-585-006	02-460-018 (one) 20-460-017 (one)	32-585-007	32-820-021
***** 02-691-403	4-Channel	20-410-014	32-585-006	20-460-017 (two)	32-585-007	32-820-021

** Consists of two 1 1/4 inch diameter single actuators.

*** Consists of one 1 3/4 inch diameter single actuator and one 1 1/4 inch diameter dual actuator.

**** Consists of one 1 1/4 inch diameter single actuator and one 1 1/4 inch diameter dual actuator.

***** Consists of two 1 1/4 inch diameter dual actuators.

⚠ WARNING

1. All MICO locking devices are **supplemental** safety equipment which provide additional brake holding action **when used with existing vehicle parking brake**.
2. The Low Pressure Warning Switch must be used in combination with an audible and/or visual alarm to signal any loss of system pressure. The Low Pressure Warning Switch is explained in the Operating Instructions. **Do not disconnect Low Pressure Warning Switch.** (Does not apply for 691 Brake Lock System).
3. The 691 System must be used in combination with an audible and/or visual alarm to signal any loss of brake system pressure. **Do not disconnect vehicle horn/visual alarm or Control Module alarm.**
4. All lines, fittings and adjacent areas must be cleaned of dirt or road residue before any lines or fittings are disconnected. Special care should be taken so dirt and road residue are not allowed to enter hydraulic brake system. This could contaminate the system and interfere with proper operation of brakes and MICO locking devices.
5. Follow procedures outlined in Vehicle Manufacturer's Service Manual or SAE Standards when making new connections or adding to existing brake systems. Use only steel brake tubing conforming to SAE specifications.
6. Use only proper system fluid conforming to latest SAE or DOT Standards. Improper or contaminated fluid may cause gummy deposits and softening and swelling of other rubber seals in the entire brake system. Such a condition must be corrected immediately.
7. Do not use sealants, tapes, teflon or cement compounds on any connections or fittings. The sealants or compounds can contaminate the hydraulic brake system and interfere with the operation of brake components or MICO locking device.
8. All fittings and connections must be in good condition and tightened to proper torque values as specified in the Installation and Service Instructions.
9. Separate models of MICO locking devices are available for brake fluid and for mineral based hydraulic oil. Select model to conform with the type of fluid in system.
10. Brake hoses, brake lines, MICO locking device, brake components, cylinders, and all fittings must be routinely inspected for leaks, damage or wear. Adequate fluid levels must be maintained. In the event of any loss of fluid, brake system must be carefully inspected for leaks.
11. After installation, bleed system according to vehicle manufacturer's recommendations.
12. Follow INSPECTIONS and TESTS section as outlined in the Operating Instructions.
13. The self-adhesive warning(s) accompanying each MICO locking device must be affixed in cab in view of operator.
14. The Operating Instructions must be placed in cab of vehicle in a place available to operator.

MICO could not possibly know of and give advice with respect to all conceivable applications in which these products might be used and the possible hazards and/or results of each application. MICO has not undertaken any such wide evaluation. Therefore, anyone who uses an application which is not recommended by the manufacturer, first must completely satisfy himself that a danger will not be created by the application selected, or by the particular model of our product that is selected for the application.

MICO has made every attempt to present accurate information in catalogs, brochures and other printed material. MICO can accept no responsibility for errors from unintentional oversights that may exist. Due to a continuous program of product improvement, materials, specifications, and product documentation are subject to change without notice or obligation.

MICO is a registered trademark of MICO, Inc. MICO is registered in the U.S. Patent and Trademark Office as well as in Australia, Indonesia, Japan, Peoples Republic of China, South Korea, and the European Community.



Innovative Braking and Controls Worldwide

MICO, Incorporated

1911 Lee Boulevard
North Mankato, MN U.S.A. 56003-2507

Tel: +1 507 625 6426 **Fax:** +1 507 625 3212

www.mico.com