



Product Bulletin

Integrated Accumulator Charge Valve/Pump Package

DESCRIPTION

This integrated package features a MICO Accumulator Charge Valve and a Haldex W900 Gear Pump to accomplish the accumulator charge function. The function of a dual accumulator charge valve is to control the pressure in redundant accumulators used in two or more brake circuits. When the pressure in either accumulator decays to the specified low limit a charge cycle is initiated. The flow rate at which the accumulators charge is constant throughout the charging cycle. The charging cycle is complete when the pressure in both accumulators reaches the specified high limit. The brake circuits are protected from pressure spikes at startup by an internal pressure relief valve. Excess flow from the valve may be used for steering, cooling or implement functions. A relief valve is required for these functions.



BENEFITS

The package offers greater system reliability by reducing system components. It reduces potential leak points as well as plumbing and mounting hardware. Additional benefits include:

- Energy savings from greater than 90% overall pump efficiency across pressure and speed ranges
- Minimal system transients at the start and end of the accumulator charging cycle due to snap like action of the control section
- A switch port for direct mounting of low accumulator pressure warning switch
- Wide range of pump mounting and shaft configurations available

SPECIFICATIONS

Pump displacement.....	6.0 to 28 cc/rev. (0.37 to 1.7 in ³ /rev.)
Maximum pressure	207 bar (3000 PSI) continuous (higher pressure optional)
Speed	500 to 4000 RPM
Pump rotation	clockwise or counterclockwise
Pump mounting	SAE A and B 2 bolt flange other options available
Shaft	straight, tapered, spline, tang other options available
Pump inlet port	straight thread o-ring boss or flange
Accumulator charge limits	custom ranges 193 bar (2800 PSI) maximum upper limit
Accumulator charge rate	1.9 to 19.0 L/min (0.5 to 5.0 GPM) 4 options
Options	dual or single accumulator

Symbol

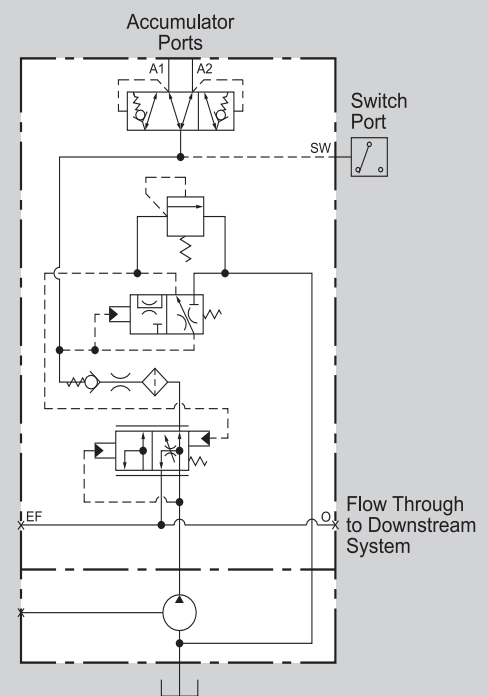

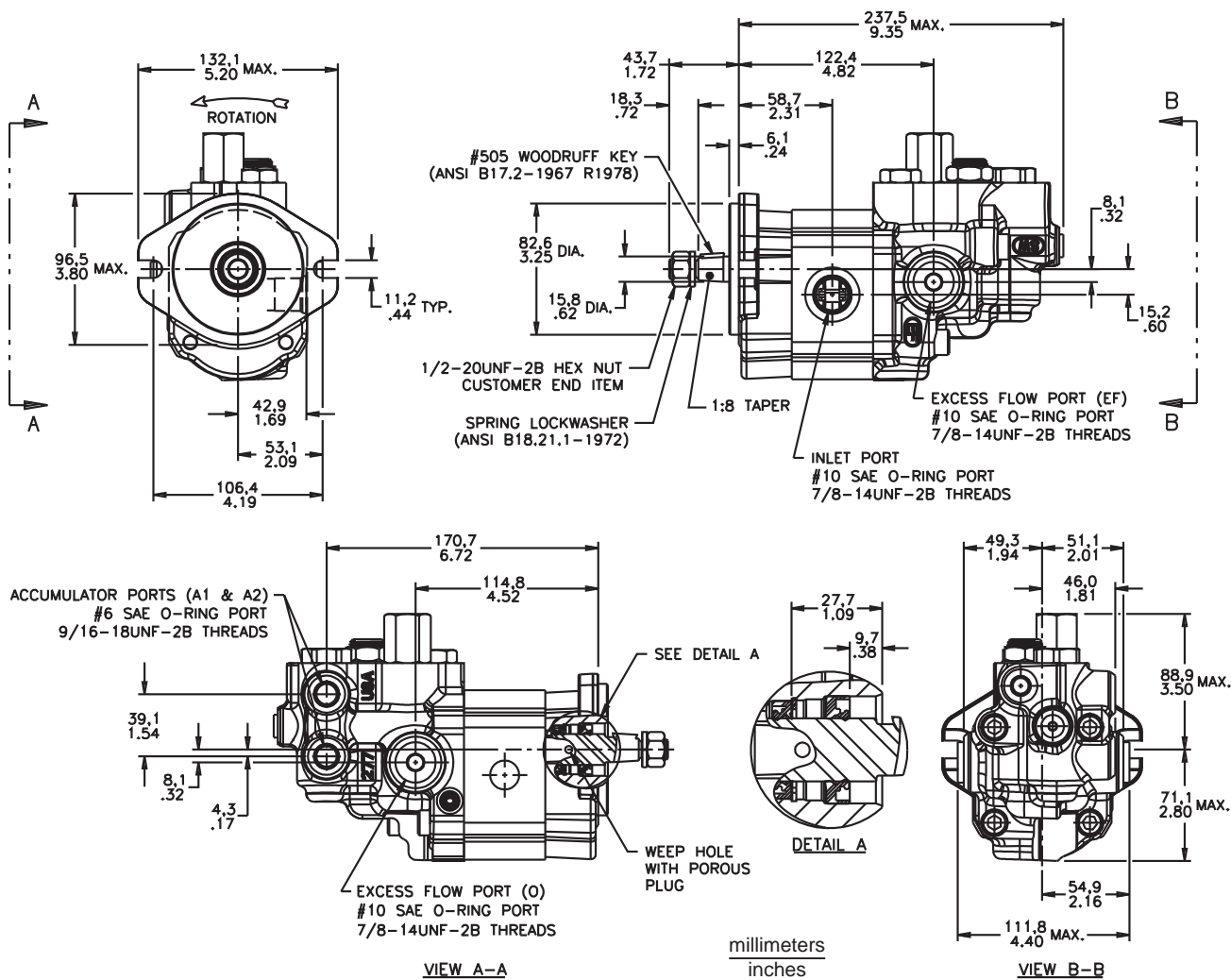

NOTE: Dimensions shown are for a model number which features SAE "A" 2-bolt flange mounting with SAE "A" 1:8 tapered shaft. Other options are available. Contact MICO, Inc. for more information.

MICO is a registered trademark of MICO, Inc. MICO is registered in the U.S. Patent and Trademark Office as well as in Australia, Canada, Indonesia, Japan, Peoples Republic of China, South Korea, and the European Community.



Innovative Braking and Controls Worldwide

MICO, Incorporated

1911 Lee Boulevard
North Mankato, MN U.S.A. 56003-2507

Tel: +1 507 625 6426 Fax: +1 507 625 3212