



Hydraulic Remote Actuators

hydraulically operated, hand control operated, pedal operated, and mechanically operated



*Versatile,
High-performance
Remote Actuators*

Why choose MICO?

MICO, Incorporated designs, manufactures and markets hydraulic components, controls, and brake systems primarily for off-road markets. We have manufacturing facilities in:

- North Mankato, Minnesota U.S.A.
- Ontario, California U.S.A.
- Worcestershire, England
- Empalme, Sonora, Mexico

Many of the world's largest off-highway OEMs value the knowledgeable staff at MICO and work with us to make their products better. Our custom-engineered products are designed with the customer requirements as the primary driver. It is our intent to help customers build their systems with our expertise in hydraulic components, braking systems and controls.

Our goal is to meet or exceed our customers' expectations in every aspect of our business.

Product lines we specialize in include:

- Actuators
- Brake Locks
- Brakes
- Controls
- Cylinders
- Electrohydraulics
- Master Cylinders
- Valves

MICO is proud to be ISO 9001 and ISO 14001 certified and continuously strive for improvement while remaining a quality leader in our field. We have been a successful business for over 60 years. Privately owned, customer driven. We look forward to working with you!



Hydraulic Remote Actuators

MICO® Remote Actuators are designed with the same quality and dependability that goes into every MICO Braking System Product. This is an important consideration when you select any brake system component.

There are several functions the various types of MICO® Remote Actuators are designed to perform.

- Hydraulic remote actuators prevent the transfer of fluid from one system to another system when used with two master cylinders.
- Hand operated remote actuators also prevent fluid transfer between systems, but can be used as the master cylinder, or prime mover as well.
- Pedal operated actuators perform the same functions as the hand operated actuators, except the operator controls these units by foot.
- Mechanically operated actuators allow you to mount your own pedal or lever arrangement to meet the specific needs of your application.

MICO® Pressure Intensifiers are ideal for applications where a low pressure source is available and a small displacement of high pressure hydraulic fluid is required.

System fluids other than DOT 3, 4, 5, or 5.1 brake fluid or mineral based hydraulic oils may require special seals. Consult MICO, Inc. for recommendations.

Catalog Index

Why choose MICO?	2
Hydraulic Remote Actuators	
(hydraulically operated)	4-10
(hand control operated)	11-13
(pedal operated)	14-16
(mechanically operated)	17-20
Pressure Intensifiers	
(hydraulically operated)	21-24
Fluid Reservoirs	25

Applications

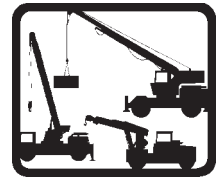

Swing Drive
Equipment



Agricultural
Equipment



Heavy Construction
Equipment



Mining Equipment

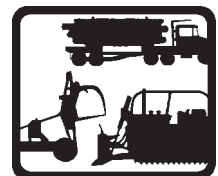

Forestry Equipment



In-Plant & Ware-
house Equipment

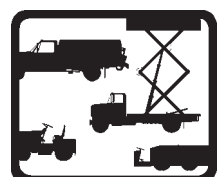

Airport Support
Vehicles



Hydraulic Remote Actuators

(hydraulically operated)

DESCRIPTION

The MICO® Remote Actuators presented in this section are actuated by a remote hydraulic pressure source such as a master cylinder.

When hydraulic pressure is developed by the primary source, pressurized fluid forces the piston assembly in the remote actuator forward. When the stem seals against the rubber seat, a positive check is established at the secondary port. From that point, output pressure and volume are equal to the input pressure and volume.

Since the bores are of the same diameter, input pressure will be the same as output pressure except when moving the piston. The spring preload must be overcome by the primary pressure source.

When energizing the system from the secondary pressure source, the pressure and volume at the outlet port will equal input pressure and volume, less the stem clearance.

FEATURES

- Back to back cups prevent transfer of fluid from one system to the other
- Standard porting for easy tubing connections
- Available with seals for DOT 3, 4, 5 and 5.1 brake fluid or mineral base hydraulic oil

Typical System Schematics

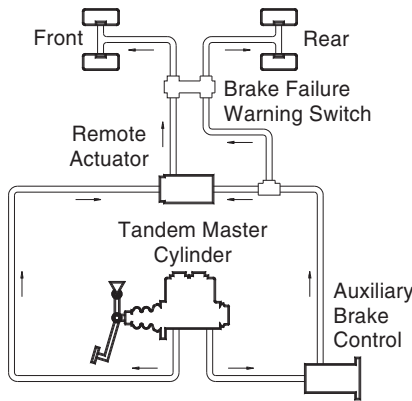

Single Master Cylinder Actuation

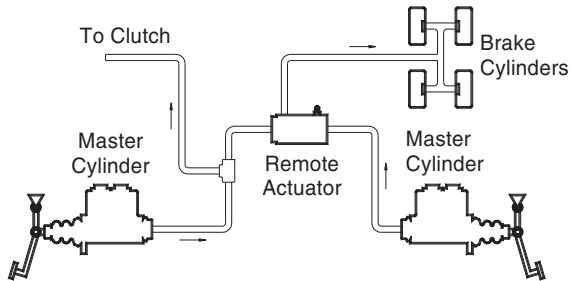

Two Master Cylinder Actuation

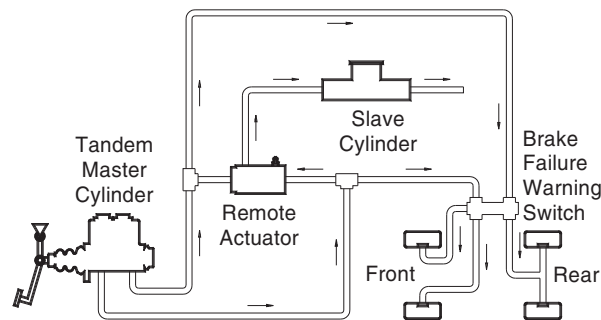

Single Master Cylinder Actuation

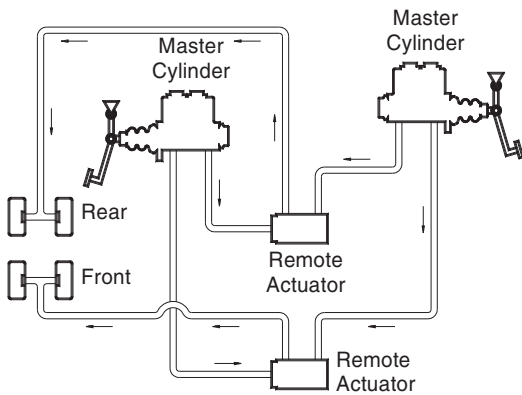

Two Master Cylinder Actuation

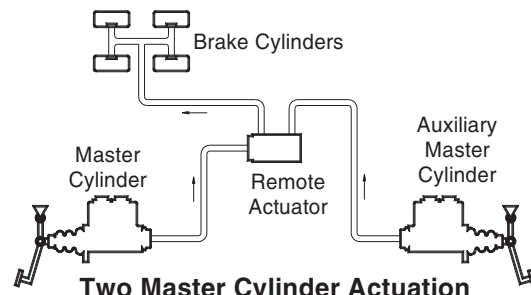

Two Master Cylinder Actuation

Hydraulic Remote Actuators

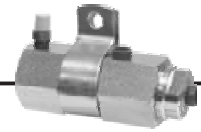

Hydraulically Operated

millimeters
inches

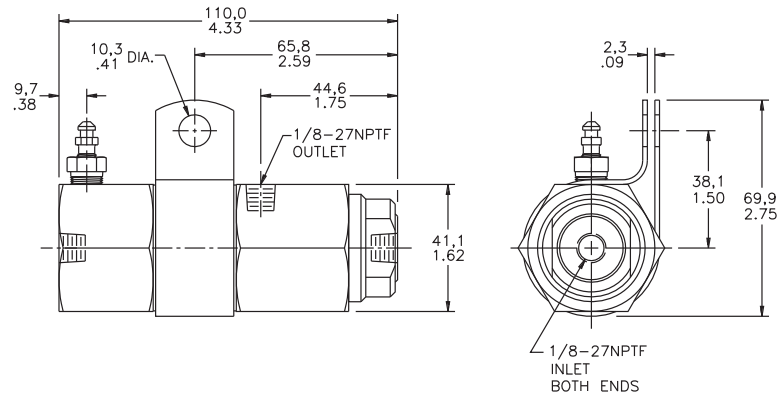

SPECIFICATIONS

Model Number	Fluid Type	Bore Diameter	Total Stroke	Effective Stroke	Output Effective Displacement	Remote Actuating Displacement
02-460-036	BF	1.00 in	0.58 in	0.47 in	0.36 in ³	0.45 in ³

BF = DOT 3, 4, 5 and 5.1 brake fluid.

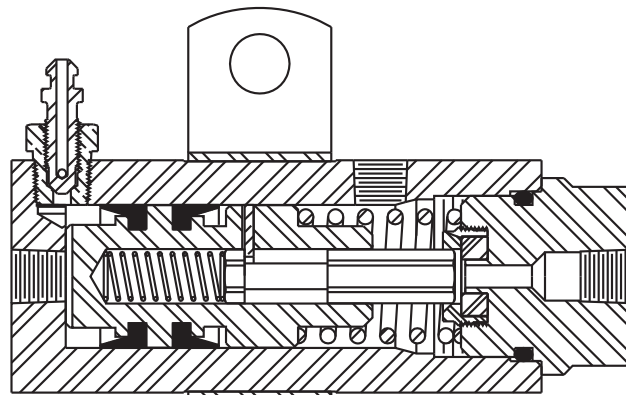

Hydraulic Remote Actuators



Hydraulically Operated

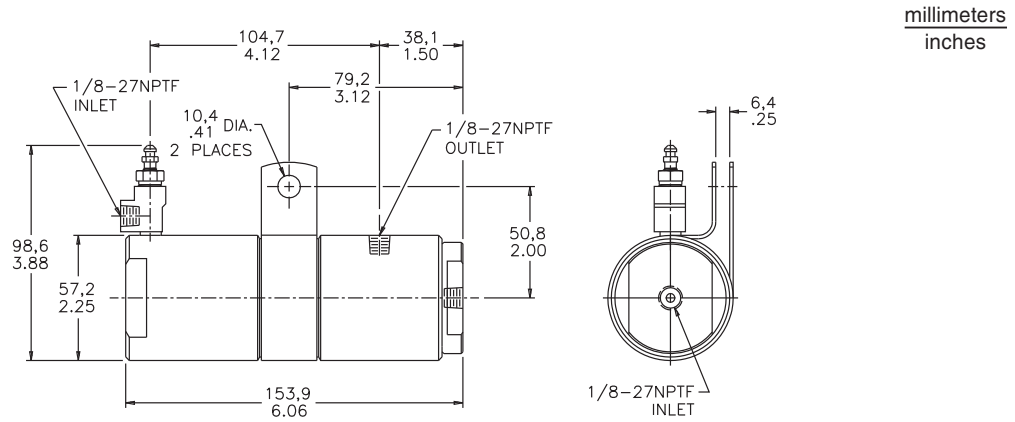

Dimensions may vary slightly by model number.

SPECIFICATIONS

Model Number	Fluid Type	Bore Diameter	Total Stroke	Effective Stroke	Output Effective Displacement	Remote Actuating Displacement
02-460-046	BF	1.50 in	1.12 in	1.00 in	1.77 in ³	1.98 in ³
03-460-086	HO	1.50 in	1.12 in	1.00 in	1.77 in ³	1.98 in ³

HO = mineral base hydraulic oil BF = DOT 3, 4, 5 and 5.1 brake fluid.

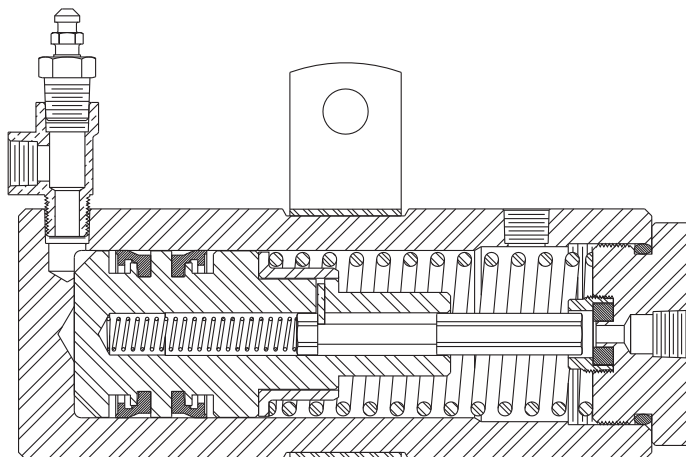

Hydraulic Remote Actuators



Hydraulically Operated

millimeters
inches

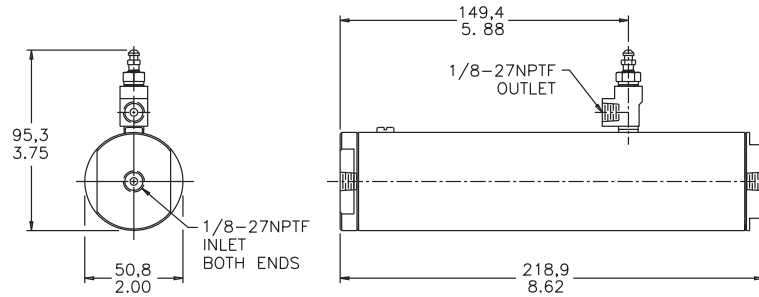

Dimensions may vary slightly by model number.

SPECIFICATIONS

Model Number	Fluid Type	Bore Diameter	Total Stroke	Effective Stroke	Output Effective Displacement	Remote Actuating Displacement
02-460-051	BF	1.50 in	2.12 in	2.0 in	3.5 in ³	3.74 in ³
02-460-052	HO	1.50 in	2.12 in	2.0 in	3.5 in ³	3.74 in ³

HO = mineral base hydraulic oil BF = DOT 3, 4, 5 and 5.1 brake fluid.

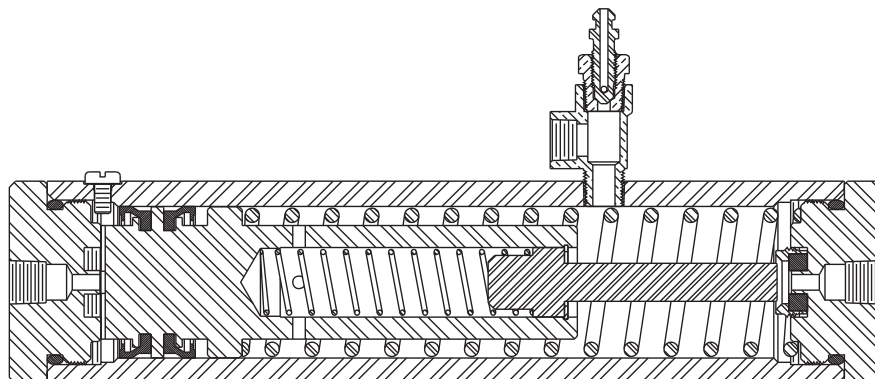



Hydraulic Remote Actuators

(hydraulically operated)

DESCRIPTION

MICO® Actuators of this type are mechanical devices that link the vehicles hydraulics with the brake system. The single actuators are used for connecting to a brake line controlled by a single input and the dual actuators are used for connecting to two brake lines controlled by a single input. Actuators are available in two different bore sizes and are capable of displacing 1.77 in³ and 2.89 in³ per side.

See page 25 for Fluid Reservoirs.

FEATURES

- Dual actuators support two separate fluid lines
- All actuators have SAE #4 o-ring ports
- Actuator pistons are hard coat anodized aluminum
- Heavy duty return springs are an advantage in "inching" applications
- Two bore sizes, 1 1/4 and 1 3/4 inch diameter
- Bleeders and/or brackets can be repositioned
- Reservoir can be remotely mounted for easy accessibility, see page 25

Typical System Schematics

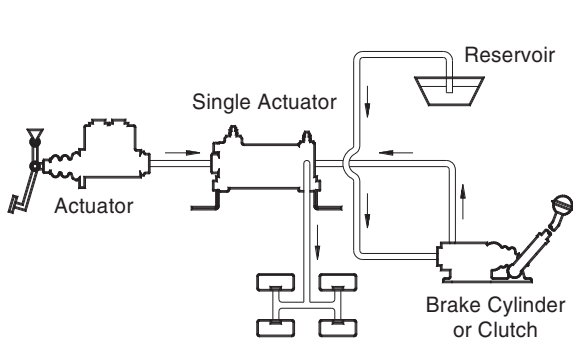

Actuator override for two remote positions

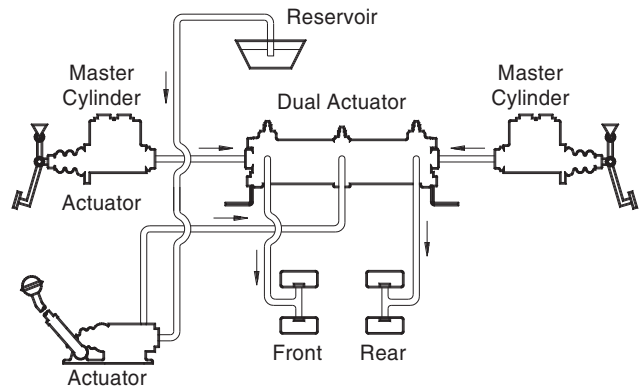

Three position actuator override

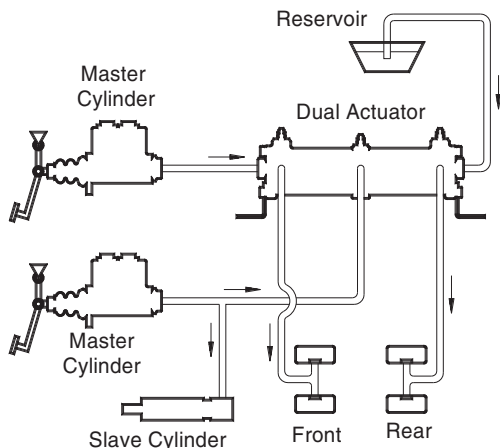

Clutch and inching

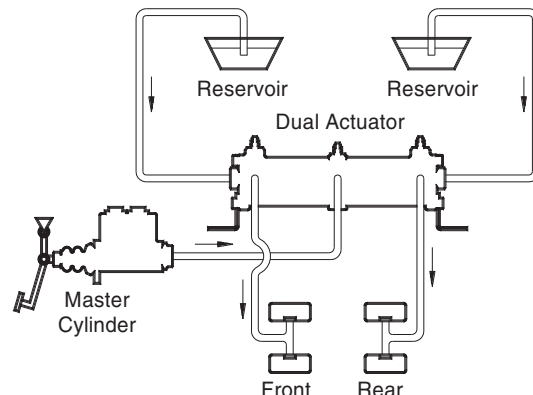

Single system split

Hydraulic Remote Actuators



Hydraulically Operated

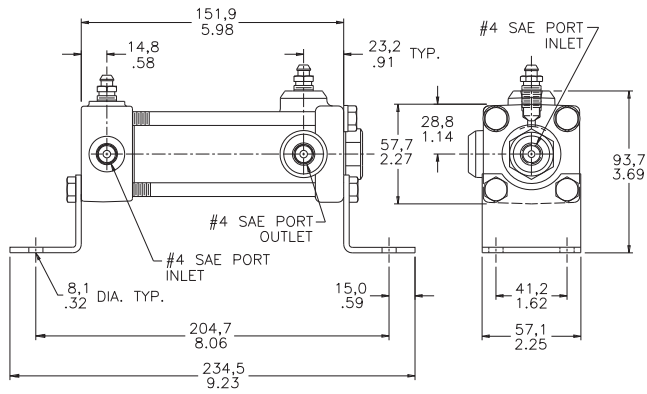

Single Actuator (1 1/4 inch diameter bore)

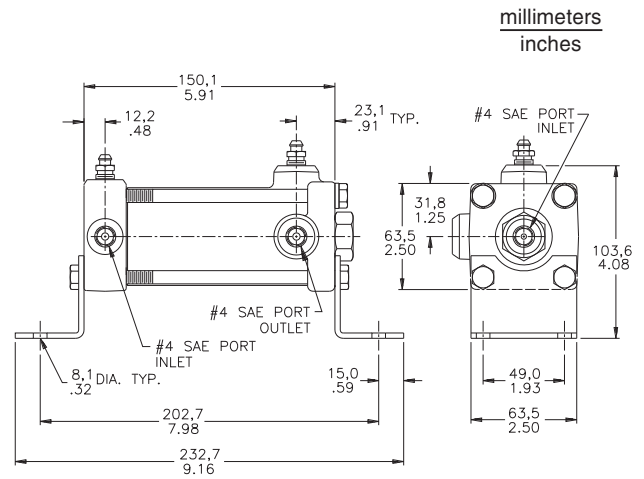

Single Actuator (1 3/4 inch diameter bore)

Dimensions may vary slightly by model number.

SPECIFICATIONS

Model Number	Fluid Type	Description	Bore Diameter	Effective Stroke	Effective Displacement
20-460-013	BF	Single	1.750 in	1.20 in	2.89 in ³
20-460-014	HO	Single	1.750 in	1.20 in	2.89 in ³
20-460-018	BF	Single	1.250 in	1.43 in	1.77 in ³

HO = mineral base hydraulic oil BF = DOT 3, 4, 5 and 5.1 brake fluid.

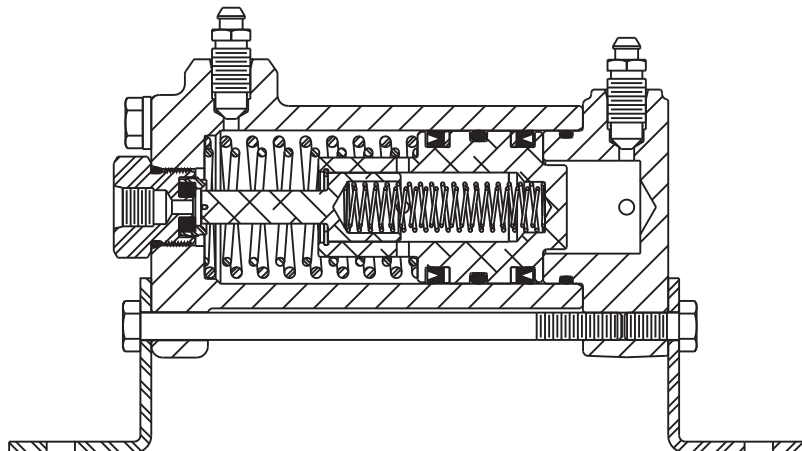

Hydraulic Remote Actuators

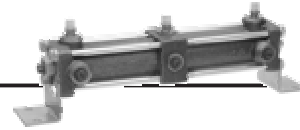

Hydraulically Operated

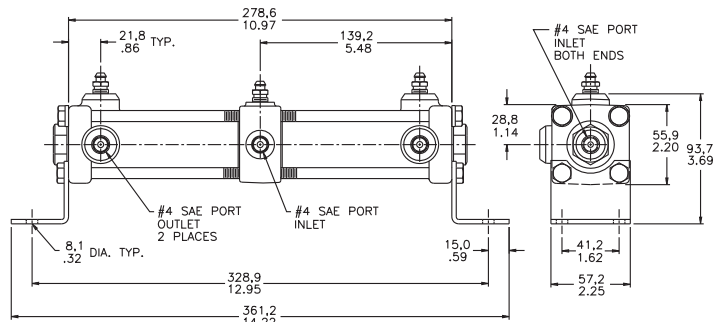

Dual Actuator (1 1/4 inch diameter bore)

millimeters
inches

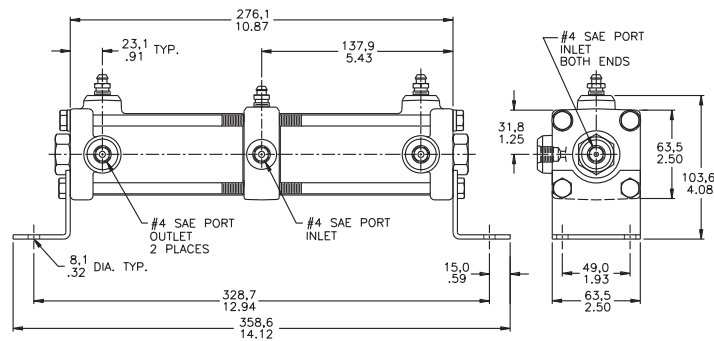

Dual Actuator (1 3/4 inch diameter bore)

Dimensions may vary slightly by model number.

SPECIFICATIONS

Model Number	Fluid Type	Description	Bore Diameter	Effective Stroke	Effective Displacement Per Side
20-460-012	BF	Dual	1.750 in	1.20 in	2.89 in ³
20-460-015	HO	Dual	1.750 in	1.20 in	2.89 in ³
20-460-017	BF	Dual	1.250 in	1.43 in	1.77 in ³

HO = mineral base hydraulic oil BF = DOT 3, 4, 5 and 5.1 brake fluid.

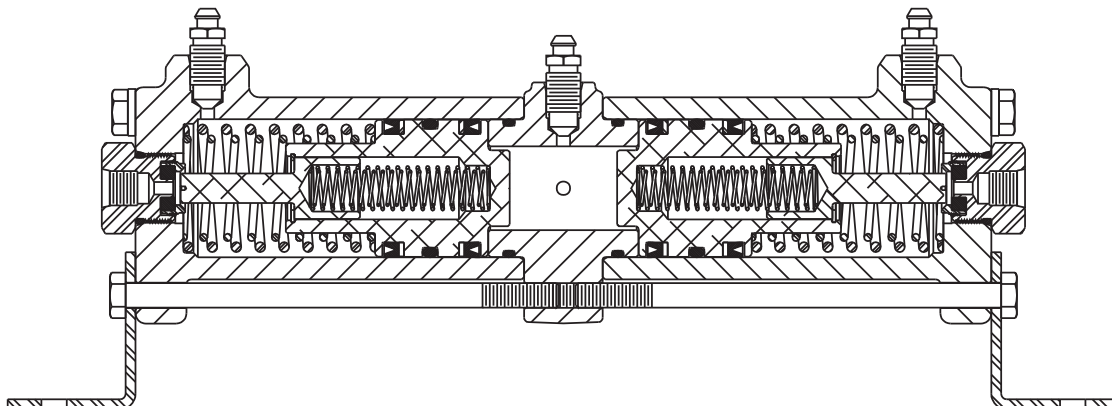



Hydraulic Remote Actuators

(hand control operated)

DESCRIPTION

MICO® Remote Actuators of this type are actuated by a force exerted on the push rod by various types of hand controls.

Initial application pressure moves the floating piston assembly forward. This action seals off fluid flow from the reservoir.

Further application builds up pressure and forces fluid out of the outlet port to the brake or clutch.

When application pressure is released, the floating piston assembly is forced back by the return spring.

See page 25 for Fluid Reservoirs.

FEATURES

- Rugged heavy duty construction
- Reservoir can be remotely mounted for easy accessibility, see page 25
- Available with seals for DOT 3, 4, 5 and 5.1 brake fluid or mineral base hydraulic oil
- Some models feature a ratchet type lock/release mechanism in the handle

Typical System Schematics

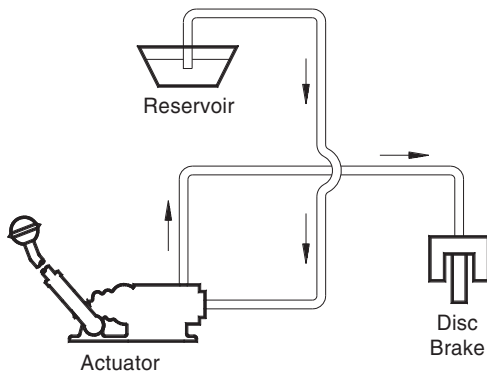

Single Actuator

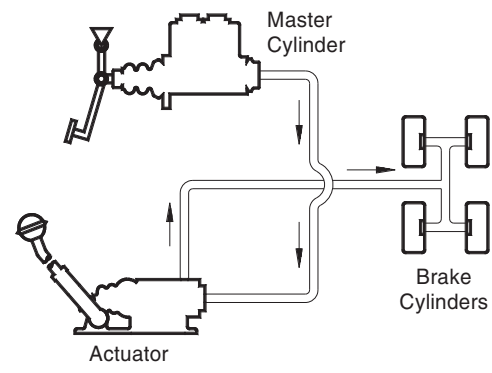

Single Actuator

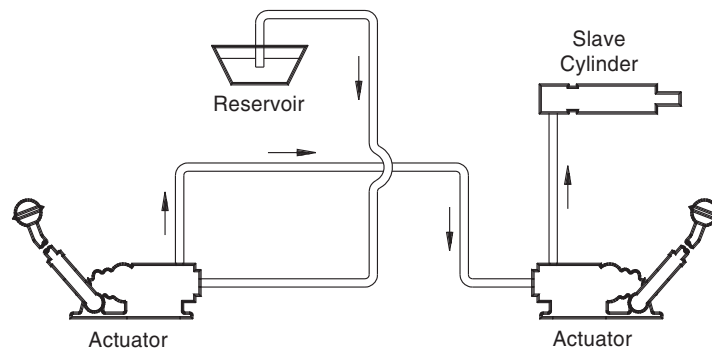

Two Actuators

Hydraulic Remote Actuators

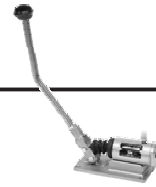

Hand Control Operated

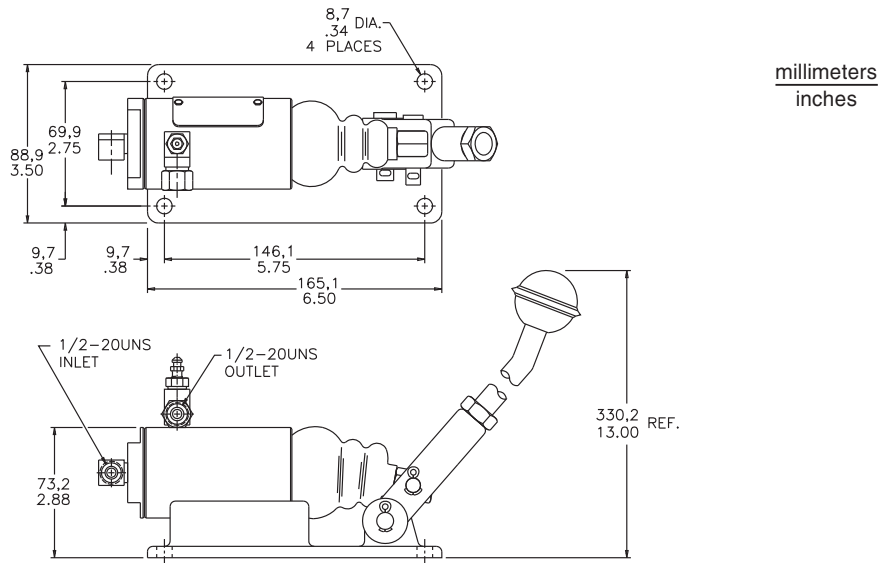

Non-ratchet lever type handle

Dimensions may vary slightly by model number.

SPECIFICATIONS

Model Number	Fluid Type	Bore Diameter	Total Stroke	Effective Stroke	Effective Displacement	Actuator Only
02-460-093	BF	1.125 in	1.25 in	1.19 in	1.18 in ³	20-080-075
03-460-028	HO	1.125 in	1.25 in	1.19 in	1.18 in ³	20-080-076

HO = mineral base hydraulic oil BF = DOT 3, 4, 5 and 5.1 brake fluid.

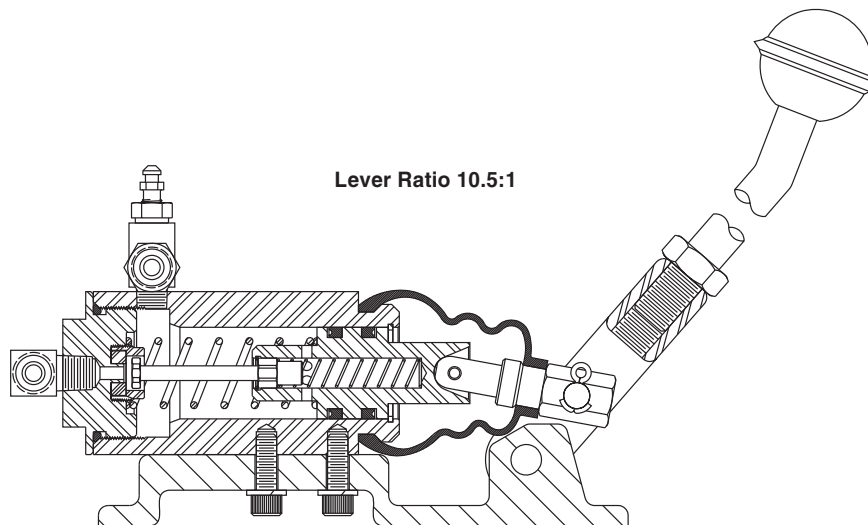

(Non-ratchet lever type handle)
100 lb maximum handle force at 875 maximum outlet pressure

Hydraulic Remote Actuators



Hand Control Operated

millimeters
inches

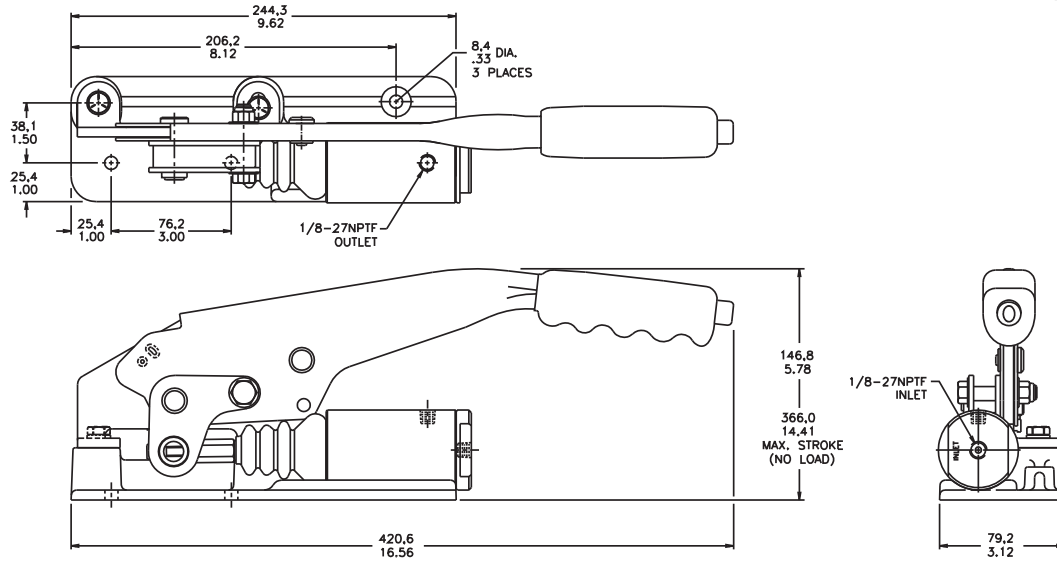

Ratchet lever type handle

Dimensions may vary slightly by model number.

SPECIFICATIONS

Model Number	Fluid Type	Bore Diameter	Total Stroke	Effective Stroke	Effective Displacement	Actuator Only
02-460-147	BF	1.125 in	1.25 in	1.19 in	1.18 in ³	None
02-460-148	HO	1.125 in	1.25 in	1.19 in	1.18 in ³	None

HO = mineral base hydraulic oil BF = DOT 3, 4, 5 and 5.1 brake fluid.

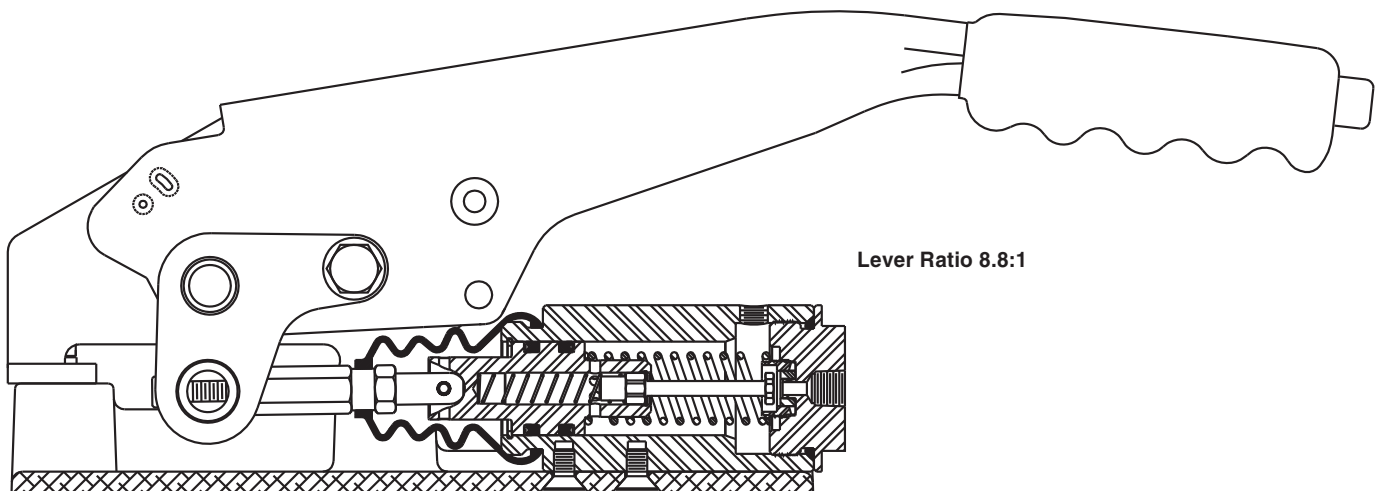

(Ratchet lever type handle with release button)
90 lb maximum lever pull



Hydraulic Remote Actuators

(pedal operated)

DESCRIPTION

MICO® Remote Actuators of this type are actuated by force applied to the push rod by various types of foot pedal controls.

Initial application pressure moves the floating piston assembly forward. This action seals off fluid flow from the reservoir.

Further application builds up pressure and forces fluid out of the outlet port to the brake or clutch.

When application pressure is released, the floating piston assembly is forced back by the return spring.

See page 25 for Fluid Reservoirs.

FEATURES

- Heavy duty industrial design
- Reservoir can be remotely mounted for easy accessibility
- Cups do not pass over replenishing ports
- Ideal for remote application of brakes or clutch
- Available with seals for DOT 3, 4, 5 or 5.1 brake fluid or mineral base hydraulic oil
- Reservoir can be remotely mounted for easy accessibility, see page 25

Typical System Schematics

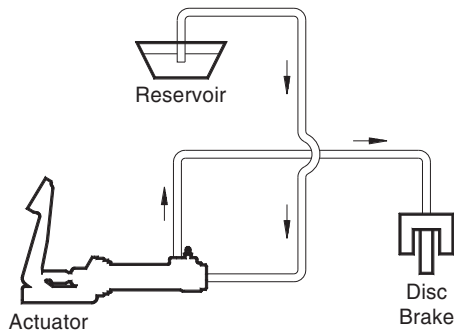

Single Actuator

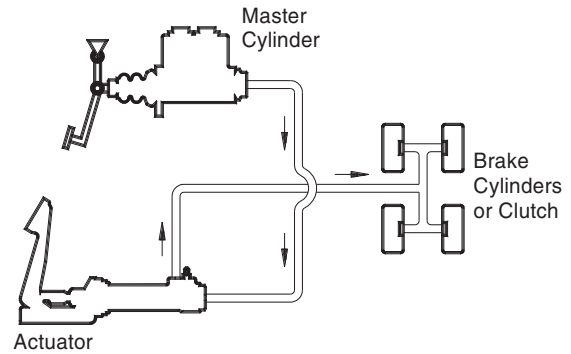

Single Actuator

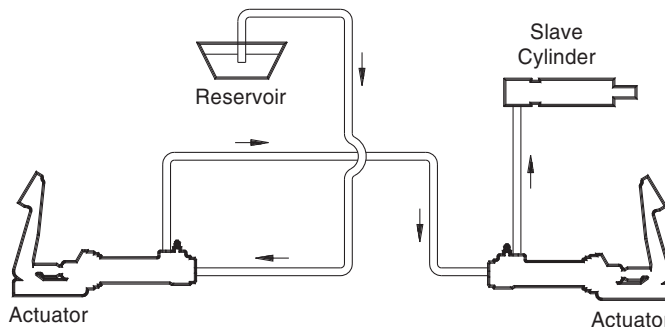

Two Actuators

Hydraulic Remote Actuators

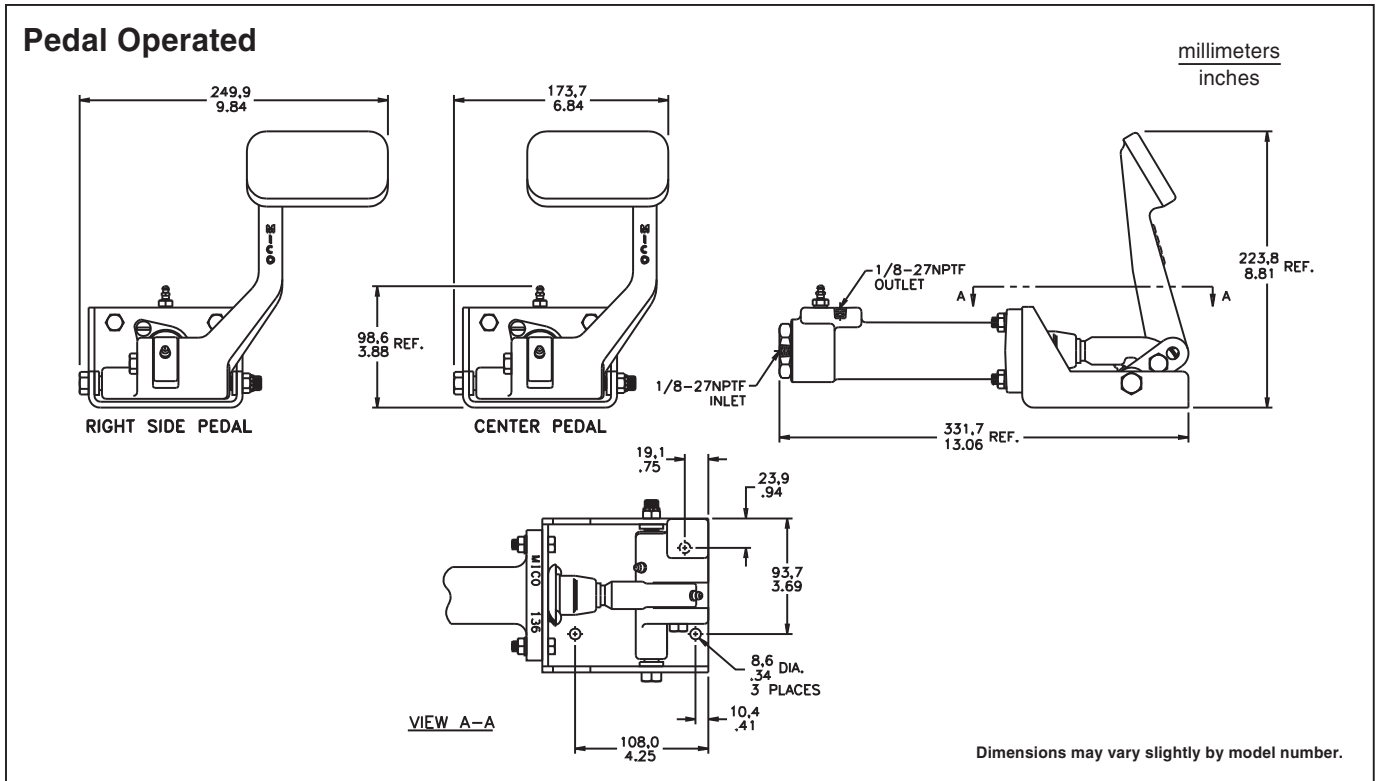
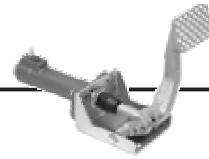

SPECIFICATIONS

Model Number	Fluid Type	Pedal Position	Bore Diameter	Total Stroke	Effective Stroke	Effective Displacement	Actuator Only
03-460-055	BF	Right Side	1.125 in	1.062 in	1.000 in	0.99 in ³	03-460-131
03-460-057	BF	Center	1.125 in	1.062 in	1.000 in	0.99 in ³	03-460-131
03-460-058	HO	Right Side	1.125 in	1.062 in	1.000 in	0.99 in ³	None
03-460-062	HO	Center	1.125 in	1.062 in	1.000 in	0.99 in ³	None

HO = mineral base hydraulic oil BF = DOT 3, 4 5 and 5.1 brake fluid.

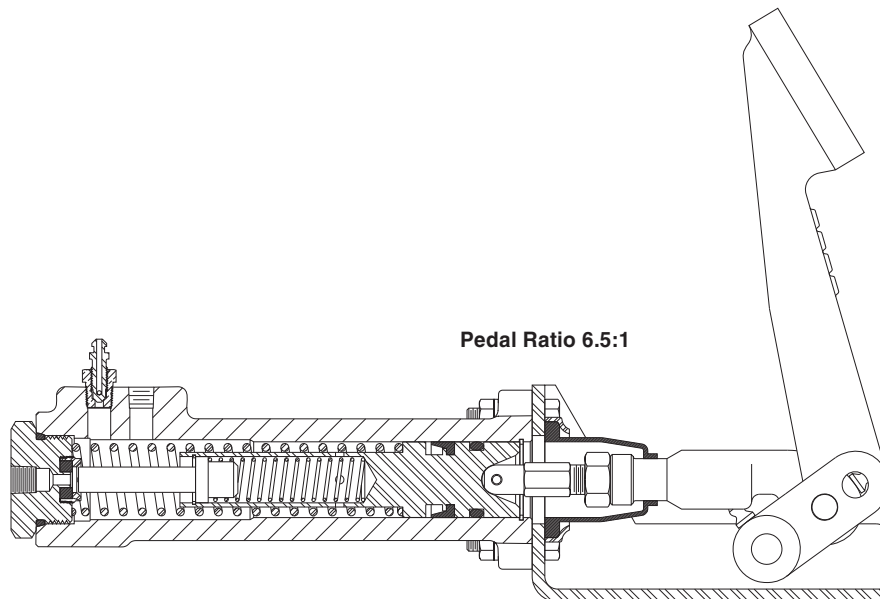

Hydraulic Remote Actuators



Pedal Operated

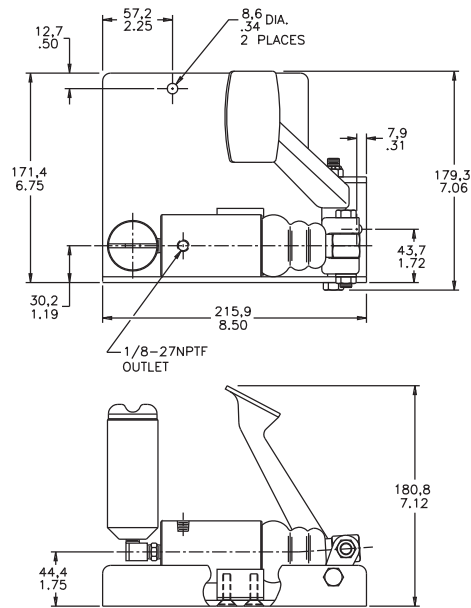

millimeters
inches

Dimensions may vary slightly by model number.

SPECIFICATIONS

Model Number	Fluid Type	Pedal Position	Bore Diameter	Total Stroke	Effective Stroke	Effective Displacement	Actuator Only
* 02-460-127	BF	Right Side	1.125 in	1.250 in	1.187 in	1.18 in ³	20-080-077
* 02-460-128	HO	Right Side	1.125 in	1.250 in	1.187 in	1.18 in ³	20-080-078
03-460-067	BF	Right Side	1.125 in	1.250 in	1.187 in	1.18 in ³	20-080-077
03-460-068	HO	Right Side	1.125 in	1.250 in	1.187 in	1.18 in ³	20-080-078

* Includes 20-920-002 fluid reservoir.

HO = mineral base hydraulic oil BF = DOT 3, 4 5 and 5.1 brake fluid.

RESERVOIR

Model Number	Fluid Type	Capacity
** 20-920-002	BF or HO	3.3 in ³

** Filler cap with baffle and breather.

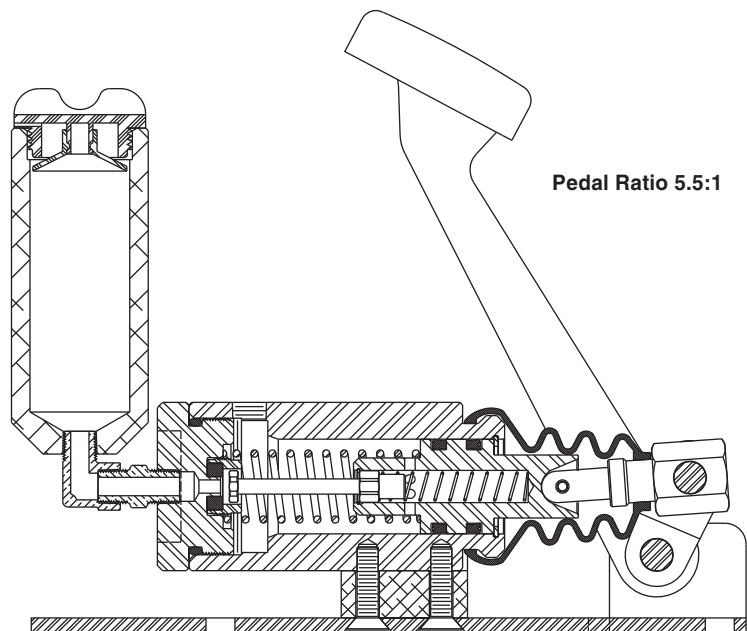



Hydraulic Remote Actuators

(mechanically operated)

DESCRIPTION

MICO® Remote Actuators of this type are actuated by a force exerted on the push rod by various types of mechanical linkage.

Initial application pressure moves the floating piston assembly forward. This action seals off fluid flow from the reservoir.

Further application builds up pressure and forces fluid out of the outlet port to the brake or clutch.

When application pressure is released, the floating piston assembly is forced back by the return spring.

See page 25 for Fluid Reservoirs.

FEATURES

- Rugged heavy-duty construction
- Reservoir can be remotely mounted for easy accessibility
- Case hardened piston for extended service life
- Ideal for remote application of brakes or clutch
- Available with seals for brake fluid or hydraulic oil
- Reservoir can be remotely mounted for easy accessibility, see page 25

Typical System Schematics

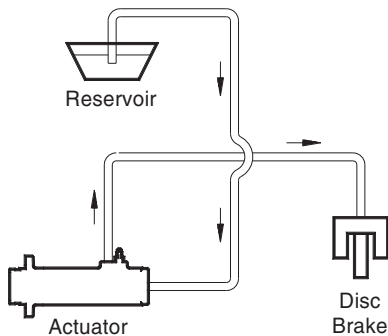

Single Actuator

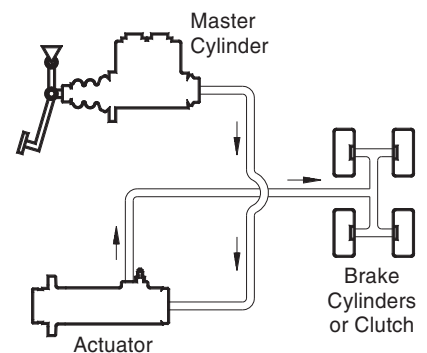

Single Actuator

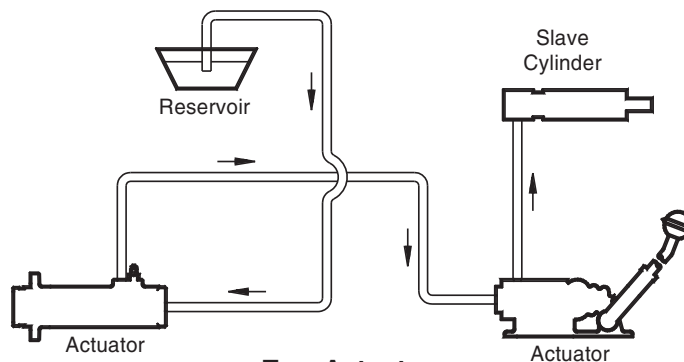

Two Actuators

Hydraulic Remote Actuators

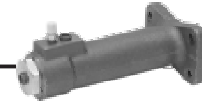

Mechanically Operated

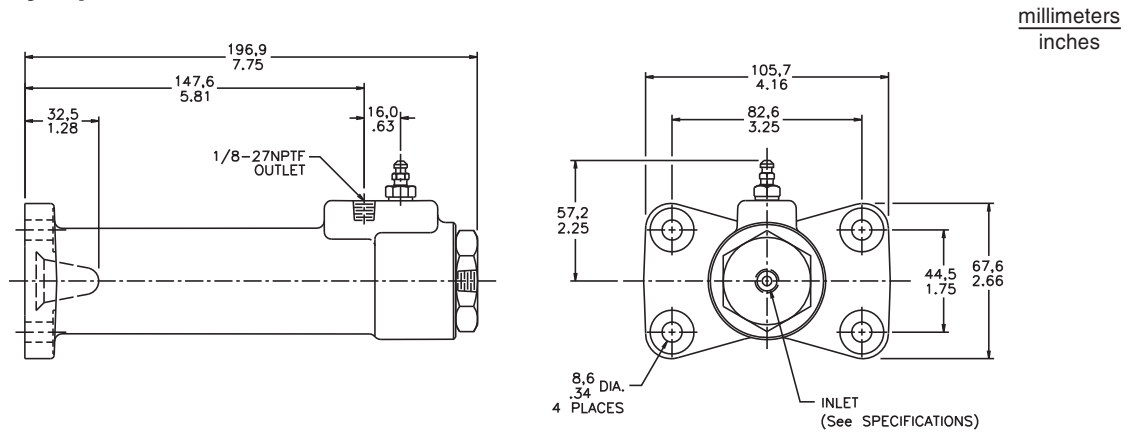

Dimensions may vary slightly by model number.

SPECIFICATIONS

Model Number	Fluid Type	Bore Diameter	Total Stroke	Effective Stroke	Effective Displacement	Inlet Port
02-460-066	BF	1.125 in	1.593 in	1.437 in	1.43 in ³	1/8-27NPTF
02-460-072	HO	1.125 in	1.593 in	1.437 in	1.43 in ³	1/8-27NPTF
02-460-152	HO	1.125 in	1.593 in	1.437 in	1.43 in ³	1/4-18NPTF

HO = mineral base hydraulic oil BF = DOT 3, 4 5 and 5.1 brake fluid.

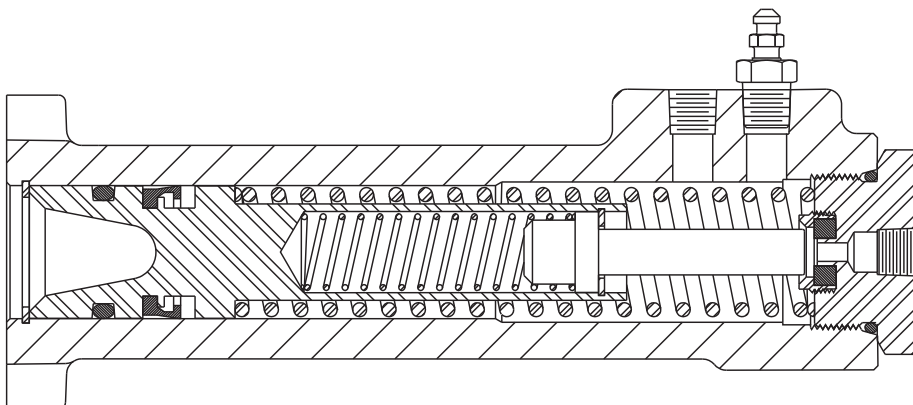

Hydraulic Remote Actuators

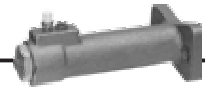

Mechanically Operated

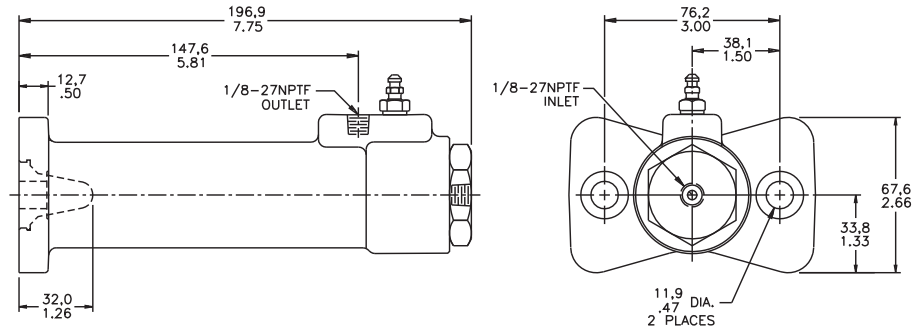

millimeters
inches

Dimensions may vary slightly by model number.

SPECIFICATIONS

Model Number	Fluid Type	Bore Diameter	Total Stroke	Effective Stroke	Effective Displacement
02-460-068	HO	1.125 in	1.593 in	1.437 in	1.43 in ³
12-460-002	BF	1.125 in	1.593 in	1.437 in	1.43 in ³

HO = mineral base hydraulic oil BF = DOT 3, 4 5 and 5.1 brake fluid.

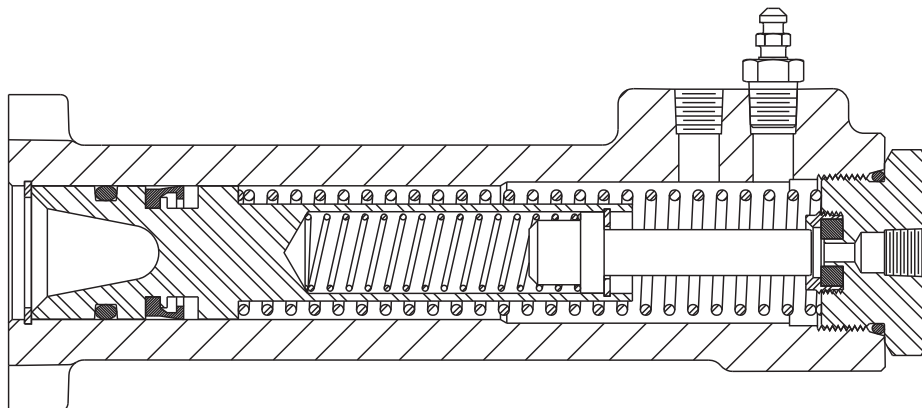

Hydraulic Remote Actuators

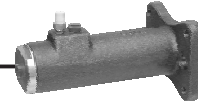

Mechanically Operated

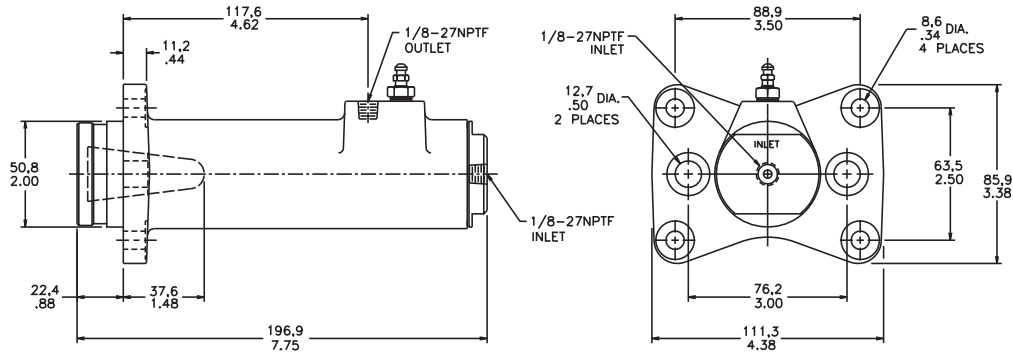

millimeters
inches

Dimensions may vary slightly by model number.

SPECIFICATIONS

Model Number	Fluid Type	Bore Diameter	Total Stroke	Effective Stroke	Effective Displacement
02-460-061	BF	1.500 in	1.593 in	1.437 in	2.54 in ³
03-460-054	HO	1.500 in	1.593 in	1.437 in	2.54 in ³

HO = mineral base hydraulic oil BF = DOT 3, 4 5 and 5.1 brake fluid.

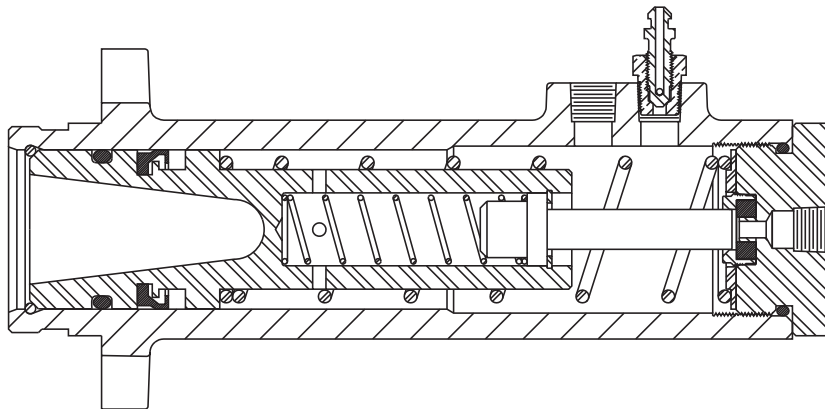



Pressure Intensifiers

DESCRIPTION

There are MICO® Intensifier models available that act as fluid separators. Different fluids can be used in the assist section than in the cylinder section.

In mechanically linked intensifiers of this type the piston in the assist section is forced forward. This action moves the piston assembly in the cylinder section forward, thus preventing fluid flow from the reservoir. With additional pressure the fluid in the cylinder section is forced out the outlet port to a disc brake or other application.

See page 25 for Fluid Reservoirs.

FEATURES

- For use when a low pneumatic or hydraulic pressure source is available
- For use when a relatively small displacement of high pressure hydraulic fluid is required
- Intensifiers available in output to input pressure ratios of 2:1, 5:1 and 9:1, also 1:1 for use as a remote actuator of fluid separator
- Ideal for disc brake applications and various industrial applications
- Reservoir can be remotely mounted for easy accessibility, see page 25

Typical System Schematics

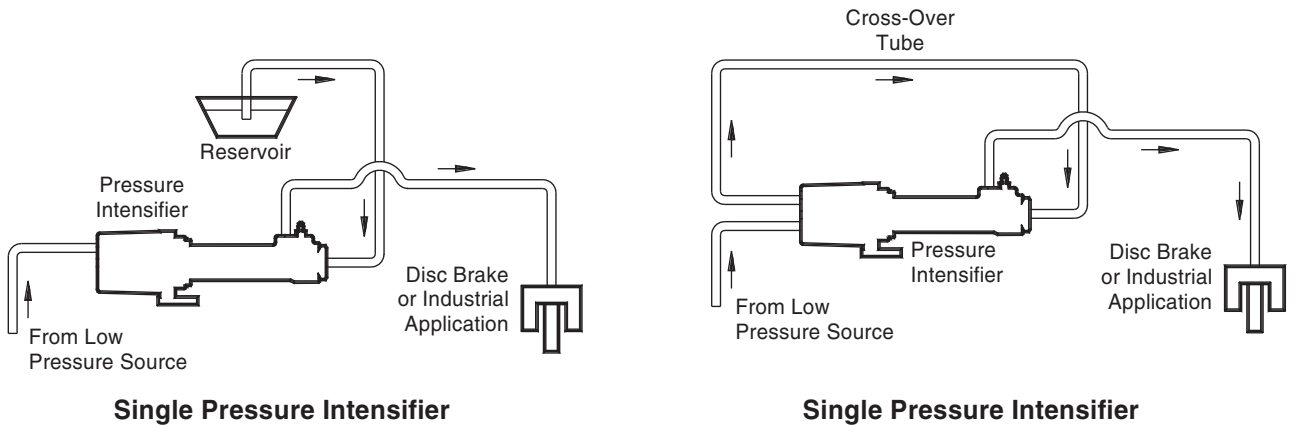

Pressure Intensifiers

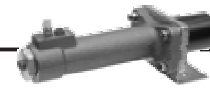

Hydraulically Operated

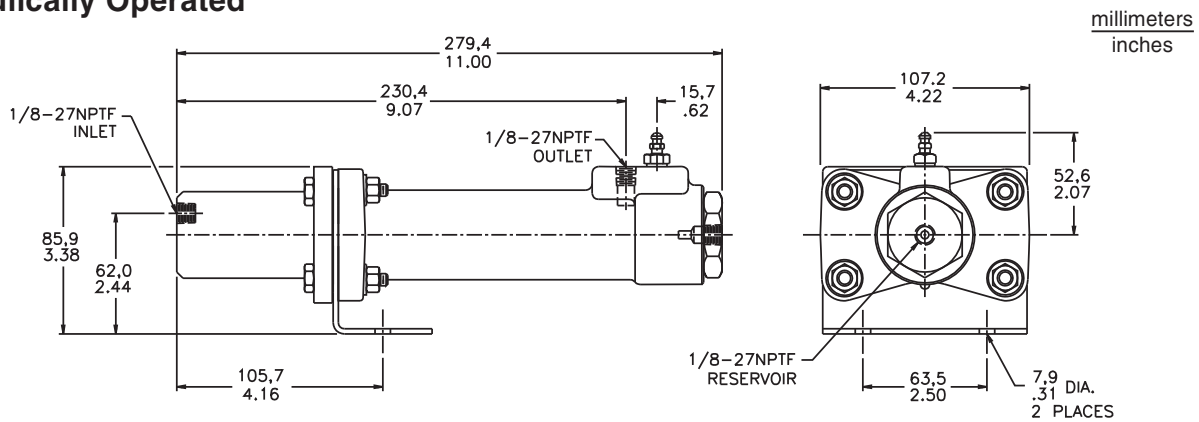

Dimensions may vary slightly by model number.

SPECIFICATIONS

Model Number	Fluid Type		Ratio Approximately	Effective Stroke	Maximum Output	Maximum Output Pressure	Maximum Input Pressure
	Inlet	Outlet					
* 02-465-029	HO	BF	1:1	1.44 in	1.44 in ³	2000 PSI	2000 PSI
02-465-031	HO	BF	2:1	1.44 in	1.44 in ³	2000 PSI	1000 PSI
02-465-032	HO	HO	2:1	1.44 in	1.44 in ³	2000 PSI	1000 PSI

HO = mineral base hydraulic oil BF = DOT 3, 4 5 and 5.1 brake fluid.

* For use as a remote actuator or fluid separator

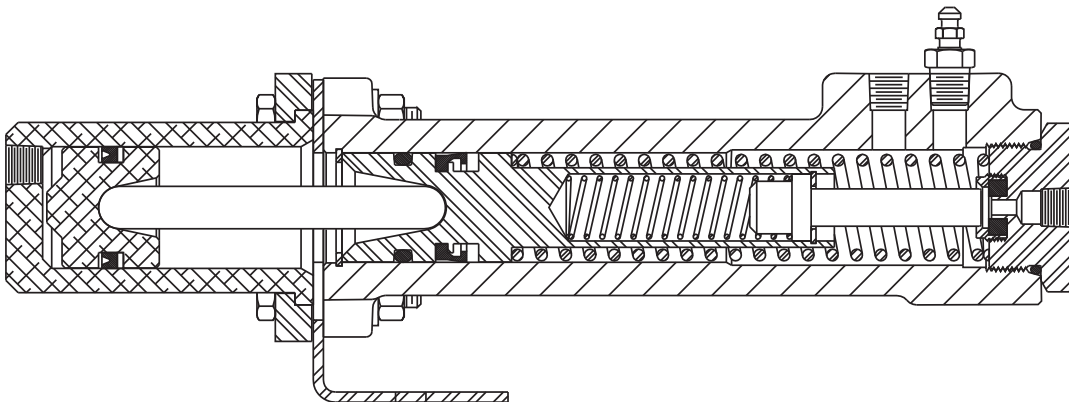

Pressure Intensifiers

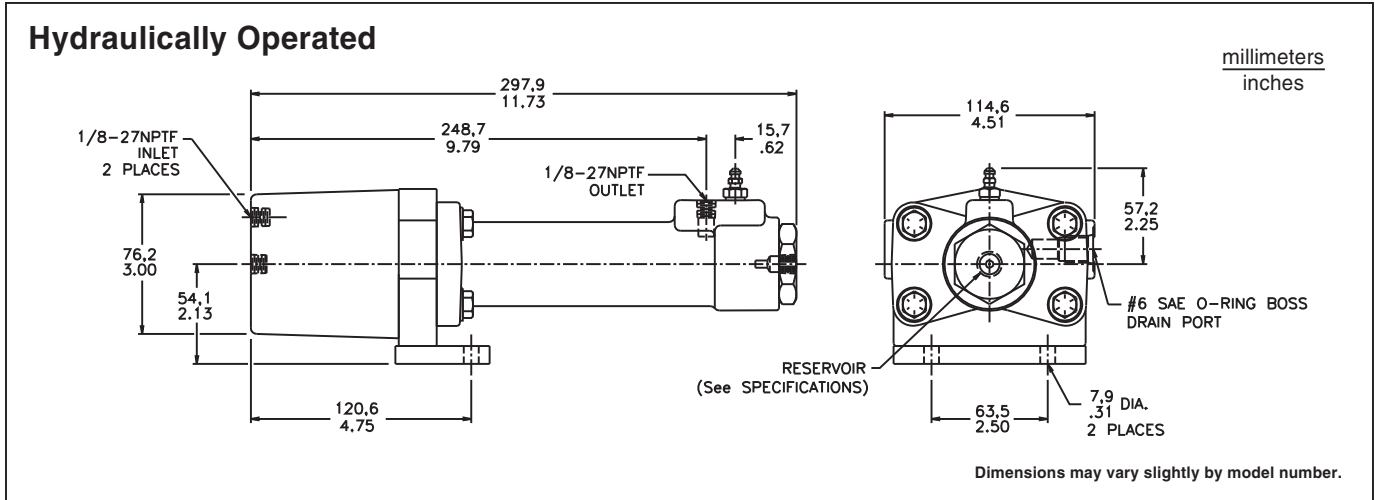

SPECIFICATIONS

Model Number	Fluid Type		Ratio Approximately	Effective Stroke	Maximum Output	Maximum Output Pressure	Maximum Input Pressure	Reservoir Port
	Inlet	Outlet						
03-465-020	HO	HO	5:1	1.44 in	1.44 in ³	2000 PSI	400 PSI	1/4-18NPTF
03-465-022	HO	HO	5:1	1.44 in	1.44 in ³	2000 PSI	400 PSI	1/8-27NPTF

HO = mineral base hydraulic oil BF = DOT 3, 4.5 and 5.1 brake fluid.

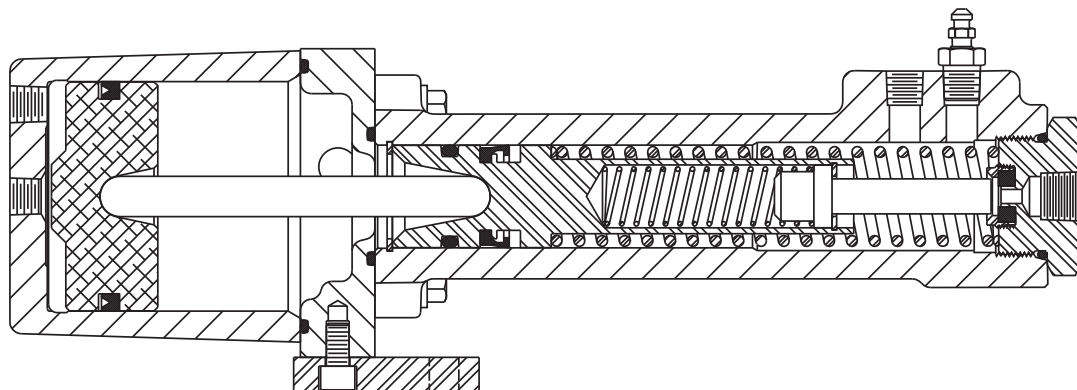

Pressure Intensifiers

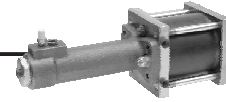

Hydraulically Operated

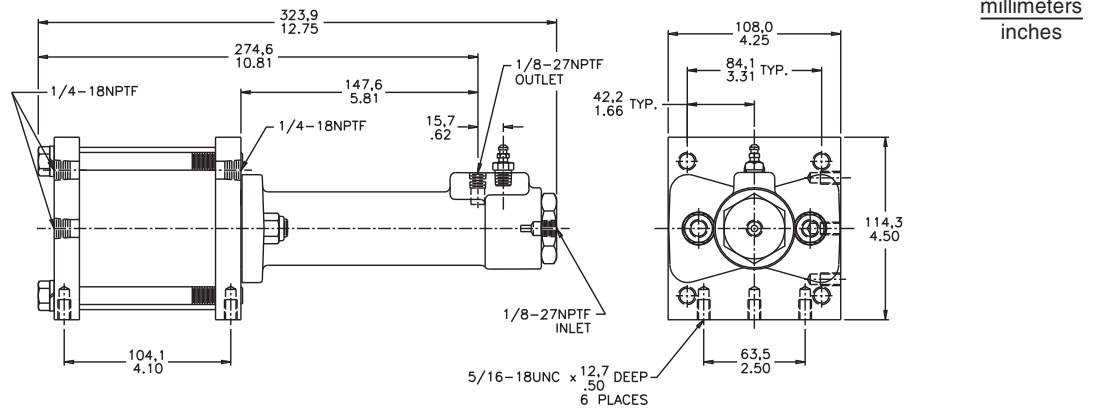

SPECIFICATIONS

Model Number	Fluid Type		Ratio Approximately	Effective Stroke	Maximum Output	Maximum Output Pressure	Maximum Input Pressure
	Inlet	Outlet					
03-465-134	HO	BF	9:1	1.91 in	1.90 in ³	2000 PSI	225 PSI
03-465-140	HO	HO	9:1	1.91 in	1.90 in ³	2000 PSI	225 PSI

HO = mineral base hydraulic oil BF = DOT 3, 4 5 and 5.1 brake fluid.

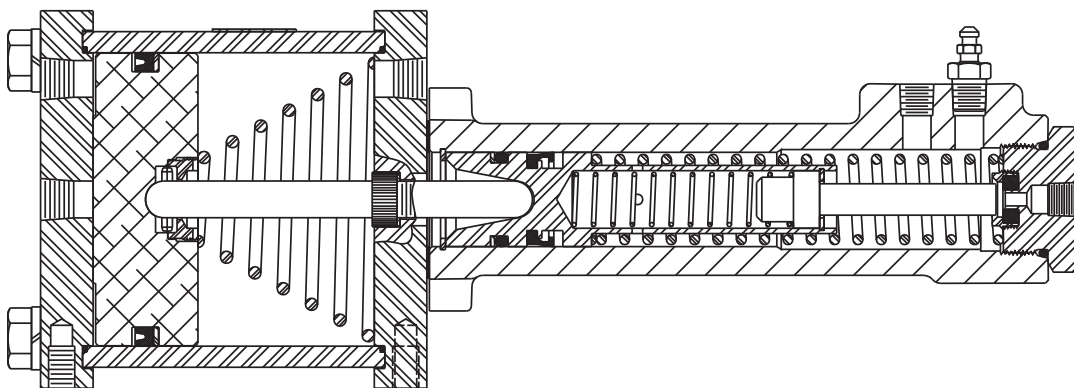



Fluid Reservoirs



Polyallomer Reservoir

- Translucent for easy view of fluid level
- Diaphragm seals out environmental contaminants
- Adaptable outlet fittings
- Sediment trap inherent to design
- Easy screw on and off filler cap
- 238 cm³ (14.5 in³) usable fluid capacity
- Designs available for use with hydraulic oil or brake fluid
- For direct or remote mounting

Metal Reservoir

- Rugged anodized aluminum housing
- Easy screw on and off filler cap with baffle and breather
- 54 cm³ (3.3 in³) usable fluid capacity
- Compact design for ease of mounting
- Adaptable outlet fittings
- For use with hydraulic oil or brake fluid
- For direct or remote mounting

SPECIFICATIONS

Polyallomer Reservoirs

Model Number	Fluid Type	Outlet Fitting	Mounting Bracket	Diaphragm Part Number
20-920-500	HO	9/16-18UNF-2A	Yes	32-490-009
20-920-520	HO	9/16-18UNF-2A	No	32-490-009
* 20-920-502	HO	9/16-18UNF-2A	Yes	none
20-920-512	HO	1/4-18NPTF (internal)	Yes	32-490-009
20-920-514	HO	1/4-18NPTF (internal)	No	32-490-009
20-920-505	BF	9/16-18UNF-2A	Yes	32-490-010
20-920-509	BF	1/4-18NPTF (internal)	Yes	32-490-010
20-920-515	BF	1/4-18NPTF (internal)	No	32-490-010

* Non-vented, o-ring cover seal - no diaphragm.

HO = mineral base hydraulic oil.

BF = DOT 3, 4, 5 and 5.1 brake fluid.

(Contact MICO regarding phosphate ester fluids.)

SPECIFICATIONS

Metal Reservoirs

Model Number	Fluid Type	Mounting Bracket
*** 20-920-002	BF or HO	No
** 20-920-006	BF or HO	Yes
20-920-009	BF or HO	Yes

** Includes two 1/4-27NPTF x 1/4 tube fittings.

*** Includes 1/8-27NPTF male 90° elbow fitting.

HO = mineral base hydraulic oil.

BF = DOT 3, 4, 5 and 5.1 brake fluid.

(Contact MICO regarding phosphate ester fluids.)

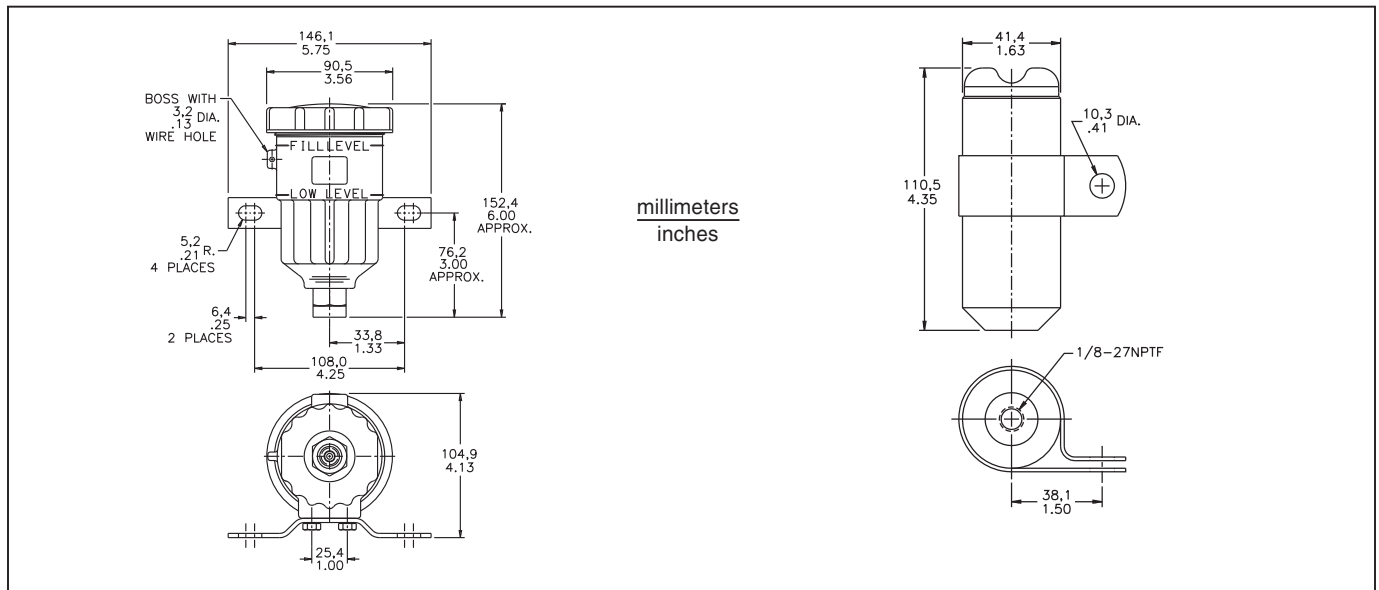

NOTES

MICO has made every attempt to present accurate information in catalogs, brochures, and other printed material. MICO can accept no responsibility for errors from unintentional oversights that may exist. Due to a continuous program of product improvement, both materials and specifications are subject to change without notice or obligation. Refer to www.mico.com for the most recent versions of our literature. If you have any further questions, please call MICO.



Innovative Braking and Controls Worldwide

MICO, Incorporated

1911 Lee Boulevard
North Mankato, MN U.S.A. 56003-2507
Tel: +1 507 625 6426 Fax: +1 507 625 3212

MICO Europe Ltd.

Goodwood Road / Pershore
Worcestershire Wr10 2RY England
Tel: +44(0)1386 555562 Fax: +44(0)1386 553955

Web Site: www.mico.com

MICO is a registered trademark of MICO, Inc. MICO is a registered in the U.S. Patent and Trademark Office as well as in Australia, Indonesia, Japan, Peoples Republic of China, South Korea, and the European Community.

PRODUCT LINE:

Brakes

Caliper Disc Brakes
Multiple Disc Brakes

Brake Locks

Electric
Mechanical

Controls

Electronic Controls
Hydraulic Throttle Controls
Pedal Controls
Switches
Transducers/Sensors

Cylinders

Drive Axle Brake Actuators
Slave Cylinders
Wheel Cylinders

Master Cylinders

Boosted Cylinders
Hydraulically and Air Actuated
Straight Bore Cylinders
Two-Stage Cylinders

Valves

Accumulator Charging
Electrohydraulic Brake
Park Brake
Pressure Modulating

Miscellaneous Components

In-line Residual Check Valves
Pump with Integrated Valves
Reservoirs