



Multiple Disc Brakes

posi-torque winch brakes, pressure override brakes,
wheel mount brakes, and driveline brakes



*Spring Apply Hydraulic
Release Multiple
Disc Brakes*

Why choose MICO?

MICO, Incorporated designs, manufactures and markets hydraulic components, controls, and brake systems primarily for off-road markets. We have manufacturing facilities in:

- North Mankato, Minnesota U.S.A.
- Ontario, California U.S.A.
- Worcestershire, England
- Empalme, Sonora, Mexico

Many of the world's largest off-highway OEMs value the knowledgeable staff at MICO and work with us to make their products better. Our custom-engineered products are designed with the customer requirements as the primary driver. It is our intent to help customers build their systems with our expertise in hydraulic components, braking systems and controls.

Our goal is to meet or exceed our customers' expectations in every aspect of our business.

Product lines we specialize in include:

- Actuators
- Brake Locks
- Brakes
- Controls
- Cylinders
- Electrohydraulics
- Master Cylinders
- Valves

MICO is proud to be ISO 9001 and ISO 14001 certified and continuously strive for improvement while remaining a quality leader in our field. We have been a successful business for over 60 years. Privately owned, customer driven. We look forward to working with you!



Spring Apply, Hydraulic Release, Multiple Disc Brakes

Safe, sure controlled braking . . . precise control of swing drives or other vehicles and equipment with swivel joints . . . positive load positioning and "run-away" protection for winches . . . virtual elimination of slippage in hydraulic motors . . . These and many other brake related problems have been solved by using a superior, quality built MICO® Multiple Disc Brake in the application.

These precisely engineered brakes are totally enclosed units applied by built-in springs and "held-off" by hydraulic pressure. Maximum torque is produced when hydraulic pressure is absent, either intentionally or due to system failure.

Many MICO brake designs have features developed specifically to solve problems encountered with other brake designs . . . Such as piston breakage, piston cocking, spring, spline or bearing failure and low torque and high torque pressure drag.

How to use this Catalog

This catalog is designed to introduce you to a selection of MICO® Multiple Disc Brakes. Each section includes features, specifications, dimensional drawings and ordering information using the catalog code.

The catalog coding describes mounting, shaft, torque and available options. The catalog code system offers considerable versatility and flexibility, enabling you to select the product for your specific application. Complete the proper online Application Data Sheet (80-500-008, 80-500-009, 80-500-010, 80-500-013)

at www.mico.com. The MICO Applications Department will analyze your specifications and recommend a multiple disc brake most suitable to the requirements.

Also included in this catalog are engineering design considerations for Multiple Disc Brake applications.

Minimum quantity orders apply to some brake combinations. Not all possible brake combinations are currently in production.

Catalog Index

Why choose MICO	2	Compact Wheel Mount Brakes	
How to use this Catalog.	3	** Motor Input	36
MICO Advantages	4	Closed Input	38
Multiple Disc Brake Applications	5	Driveline Multiple Disc Brakes.	40
Order Number Explanation	6	Driveline Multiple Disc Brakes, Through Mount	42
General Brake Information	7	Driveline Multiple Disc Brakes, Through Mount Compact	44
Multiple Disc Brakes (modular) Introduction	8	Input Face Dimensional Information	46
SAE A - Mount	10		
SAE C - Mount	12		
SAE D - Mount	14		
Multiple Disc Brakes (narrow) Introduction	16		
** SAE B - Mount	18		
Multiple Disc Brakes (compact) Introduction.	20		
SAE B - Mount	22		
Closed Output Motor Brakes	24		
Posi-Torque Winch Brakes Introduction	25		
SAE C - Mount	26		
* Pressure Override Brakes			
SAE B - Mount	28		
SAE C - Mount	30		
Large Wheel Mount Brakes			
Motor Input	32		
Closed Input.	34		

* MICO® Pressure Override Brakes provide secondary actuation when used for service braking.

** May be ordered with optional pressure override feature.

Applications

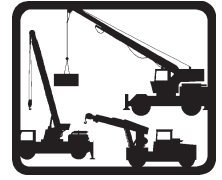

Swing Drive Equipment



Agricultural Equipment

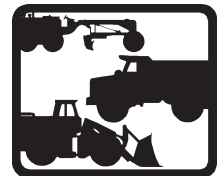

Heavy Construction Equipment

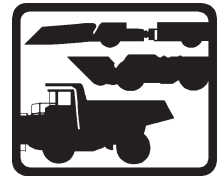

Mining Equipment

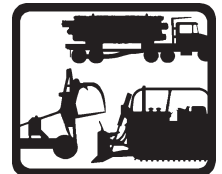

Forestry Equipment



In-Plant & Warehouse Equipment



Airport Support Vehicles

Representation and Service

In addition to the numerous design improvements over competitive models, you also get MICO representation and service which is second to none.

Direct Access to MICO Engineers

Involving the customer directly in product design and testing ensures that customer requirements are met. Our engineering staff has a very strong background in spring apply, hydraulically released brakes. As new technology becomes available, it is integrated into MICO products and when technology is not available, MICO Engineers develop it.

Simplified Disassembly and Assembly

Features such as inboard oil seal, one piece piston separators, longer torque pins and modular design concepts on many models help to simplify disassembly and assembly procedures.

Large Diameter Discs

Larger disc diameters on many models give MICO Brakes higher torque, better heat dissipation and fewer operating parts.

Extensive Testing

Testing on MICO® Multiple Disc Brakes include high pressure cycle, temperature, horizontal and vertical mount heat generation, spring life and performance, static torque, dynamic torque and leak testing.

Compact Modular Designs

Compact modular designs reduce problems encountered in many installations. Most models can be installed into restricted space with little or no additional adjustment, alignment or special brackets.



Advantages

Interchangeable with Other Fail-safe Type Brakes

MICO® Multiple Disc Brakes are interchangeable with other fail-safe type brakes using SAE and industry standards as a guide. In most cases engineering changes are not required, therefore, these brakes are economical to use.

Unique Balanced Piston Design

Some models feature a piston design that virtually eliminates areas of localized stress by more uniformly distributing the pressure generated load.



Quality & Reliability equal fewer field problems.

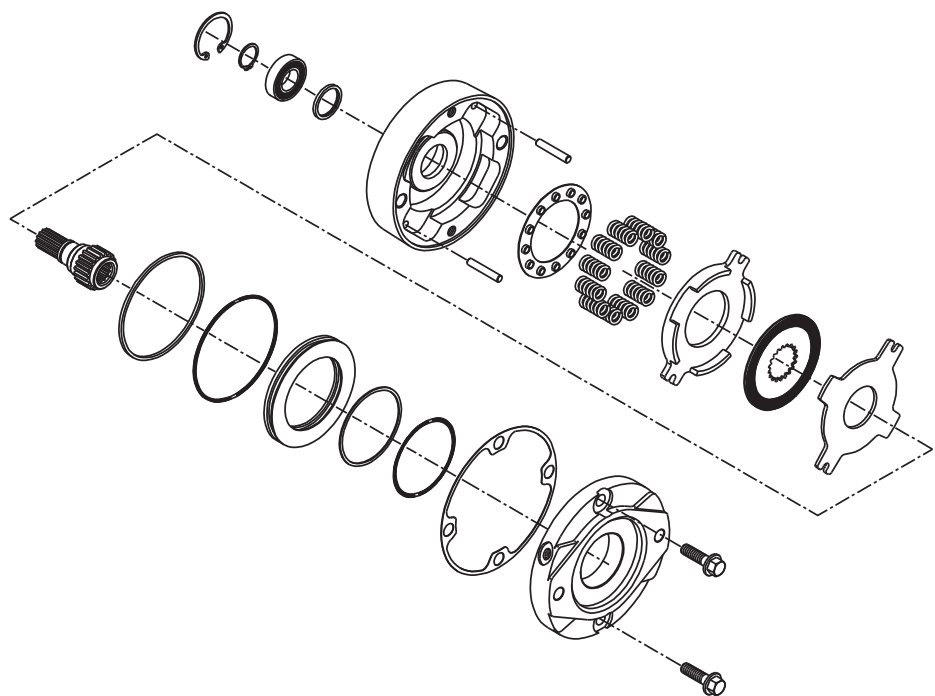



Multiple Disc Brakes

(spring apply, hydraulic release)

MICO engineers are innovators in the design of spring apply, hydraulic release multiple disc brakes, wheel brakes, closed-output motor brakes, posi-torque winch brakes and more. The engineers are committed to improving the product while reducing cost. Simple, straight forward designs result in rugged brake products. These products require less maintenance because they are designed with fewer moving parts. They are truly superior in reliability and performance.

MICO® Multiple Disc Brakes are designed for use with heavy-duty machinery and off-highway vehicles in the construction, material handling, agriculture, mining,

sanitation, utilities and timber industries. They are also used in a multitude of winching applications. Brakes of this type reduce maintenance and downtime by preventing contaminants, which cause brake lining wear, from entering the brake. They will provide consistent braking torque, positive hold, and long life in rugged environments.

Typical Multiple Disc Brake Applications

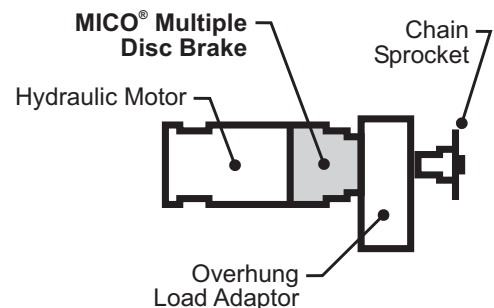
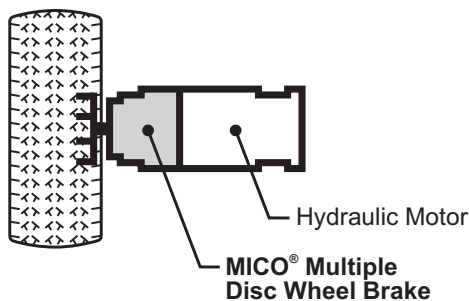
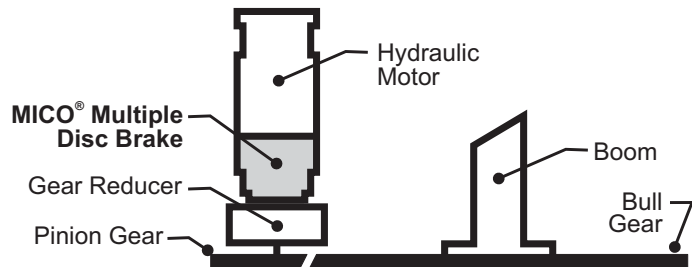
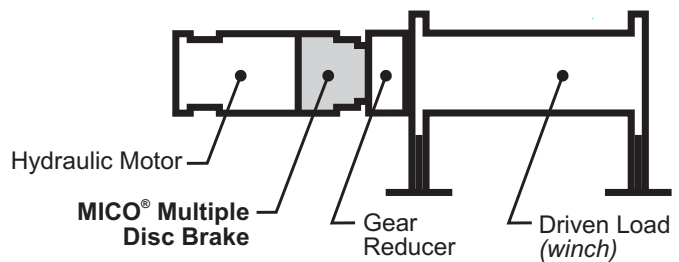

Catalog Code Explanation

The catalog code numbering system allows you to construct the brake by combining the variables that meet your needs.

Catalog code number example: 3A-060618-M.

A production number will be assigned by our Engineering Department upon receipt of your order. **Production order number example:** 13-538-004.

NOTE

For brake combinations that are not currently established, but possible, quotation and assignment of part number must be predicated by receipt, review, and acceptance of applicable multiple disc brake data sheet.

Options Explanation

Z = OIL COOLED OPTION, designated as code Z, allows flow-through or sump oil cooling for brakes which may be required to handle limited dynamic inputs. Wet brakes are also used in applications where the package is exposed to severe duty or to adverse environmental conditions such as marine winches or mining vehicles. Products that are to be used strictly wet are noted as such. Oils containing slippery or antiwear additives, such as graphite or molybdenum disulfide or extreme pressure (EP) type lubricants, may allow the brake to slip at torque levels below the rated values and should be avoided.

Specifications (Modular Design)

- Flow through - 3.8 L/min (1.0 GPM) to a maximum of 26.5 L/min (7.0 GPM)
- Case pressure should not exceed 1.03 bar (15 PSI)
- Inlet ports - SAE No. 6, 9/16-18 o-ring boss
- Outlet ports - SAE No. 6, 9/16-18 o-ring boss
- Brakes are shipped dry and the customer is responsible for adding proper type and volume of cooling oil
- Contact MICO for specific model information such as inlet/outlet port locations and sump oil fluid volume.

S = SPEED SENSOR OPTION, noted as suffix S, allows a customer supplied magnetic pickup to simply screw into the brake housing. The magnetic pickup generates an output frequency that is proportional to the rotational speed of the brake shaft.

Specifications

- Direct mounting of Flow-Tech or Motorola® Tach Drive Pickup
- Speed sensing range 0 - 4000 RPM
- Speed sensor ports - 3/8-18 straight thread or 3/4-16UNF (other sizes available upon request, consult MICO)
- Available number of notched teeth on speed sensor pickup rotor:
 - C-Mount Modular: 11, 15, 18, 40, 55 & 70 teeth
 - B-Mount Narrow: 40 & 70 teeth
- Contact MICO for specific model information such as speed sensor port locations

D = DOUBLE BEARING OPTION, is recommended only for special applications. In applications involving overhung loads, such as a sprocket or drum, a double bearing brake usually lacks the load capacity required. In these instances the use of a load adaptor is recommended.

V = VITON® (or equivalent fluorocarbon) SEALS, designated as code V, can be used in applications where standard (nitrile) o-rings and seals are incompatible.

General Brake Information

1. **Brake torque** values listed are dry static torque ratings except for the C-Mount Posi-Torque Brakes (page 26), Compact Wheel Mount Brakes (page 36), and Driveline Multiple Disc Brakes (pages 40-45).
 - a. For brakes with Z option (oil-cooled) actual torque is 67% of the dry torque listed.
 - b. Static torque may vary $\pm 10\%$ from specified values.
2. **Initial release pressure** is the point where the amount of hydraulic pressure to relieve the spring force on the rotor stack has zero brake torque with no running clearance.
3. **Full release pressure** is the amount of hydraulic pressure required to achieve full running clearance of the rotor stack.
4. Maximum continuous hydraulic input pressure is 206.8 bar (3000 PSI) unless otherwise specified.
5. All splined shafts are 30° involute, flat root, side fit per ANSI B92.1-1970 specifications unless otherwise specified.
6. All mounting flange dimensions conform to SAE Standard J744 unless otherwise specified.
7. Standard (nitrile) o-rings and seals are compatible with mineral based hydraulic fluids. For applications with non-mineral based fluids or extreme temperatures, other o-ring materials are available.
8. Brakes include mounting face gaskets and/or o-rings. Some motors and gear-boxes allow for the use of o-rings to seal the mounting faces on either side of the brake. Do not use the o-ring and face gasket together to seal a mounting face.
9. When mounting a brake use a minimum of SAE grade 5 bolts. Tighten to appropriate torque specifications for grade used. Make sure the compression load in the joint does not cause the material under the bolt to yield. Hardened flat washers may be needed.

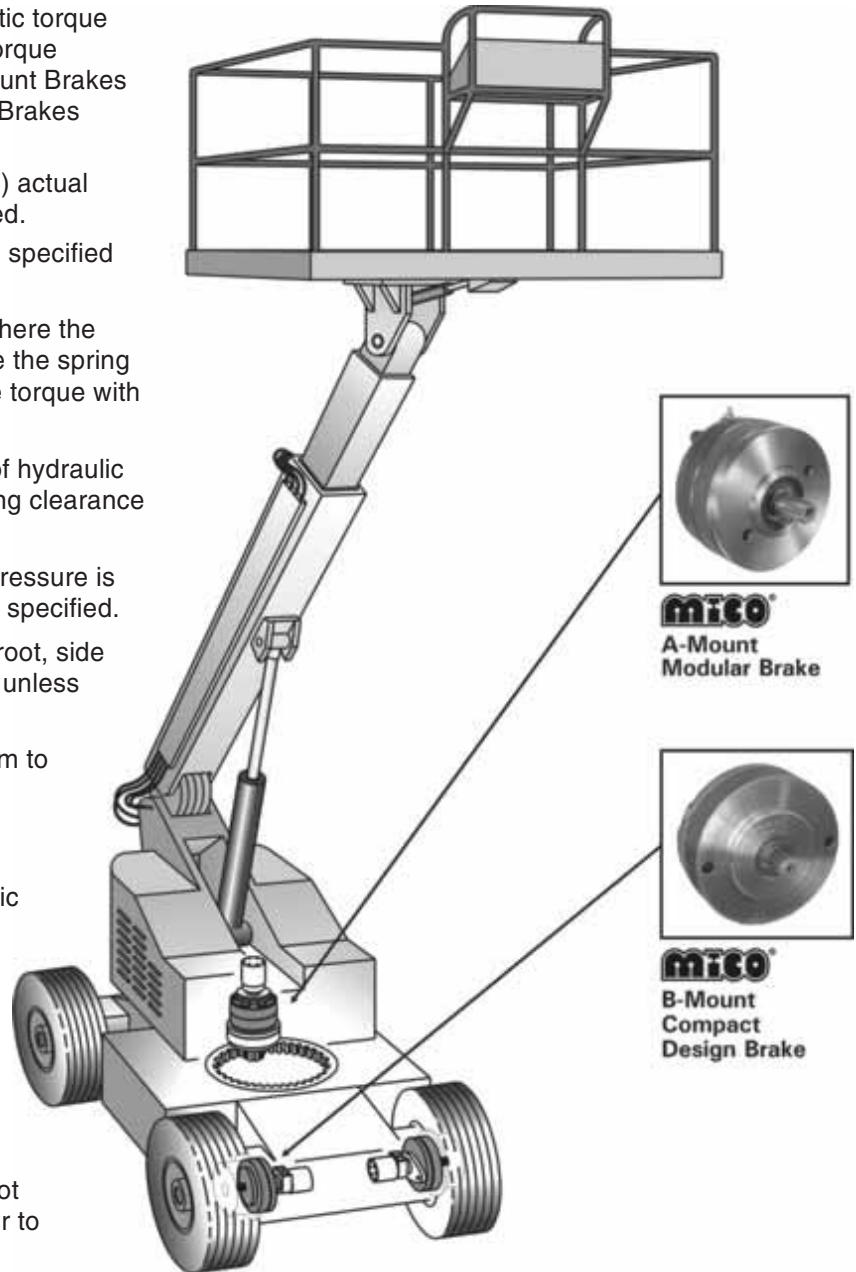

⚠ CAUTION

- A. If hydrostatic bench testing is performed on a brake assembly, release pressure must not exceed 68.9 bar (1000 PSI) unless additional mounting bolts are used for supplemental clamping.
- B. Pressures above 206.8 bar (3000 PSI) caused by spikes in the hydraulic system can shorten brake life and must be avoided.
- C. Most brakes are designed for limited side load capability at output end. Use of an overhung load adaptor is recommended for most applications. Contact MICO for further information.



Multiple Disc Brakes, Modular Design

Features

- Large diameter spline shafts virtually eliminate spline battering
- Versatile modular design
- Spring loaded, hydraulically released
- Sealed environment - isolation from contaminants
- Nitrile case seals
- High strength ductile iron construction
- Standard SAE mounting flanges

Benefits

- Eliminates problems found in competitive brake designs, such as piston breakage, piston cocking, spring failure, bearing failure and low and high torque pressure drag
- Designed primarily for use on hydraulic drive systems, can replace most fail-safe type brakes in use today, and do it economically
- Engineering changes to replace fail-safe designs are not required in most cases

Operation

MICO® Modular Multiple Disc Brakes are spring apply, hydraulic release brakes. Powerful chrome-silicon die springs automatically apply the brake's disc pack when hydraulic pressure drops, giving safe, sure braking.

Cover, Spring Plate and Pressure Plate constructed of heavy duty ductile iron.

Powerful Chrome Silicon Die Springs automatically apply the brake's disc packs when hydraulic pressure drops.

Balanced Piston Design virtually eliminates areas of localized stress by uniformly distributing the pressure generated load.

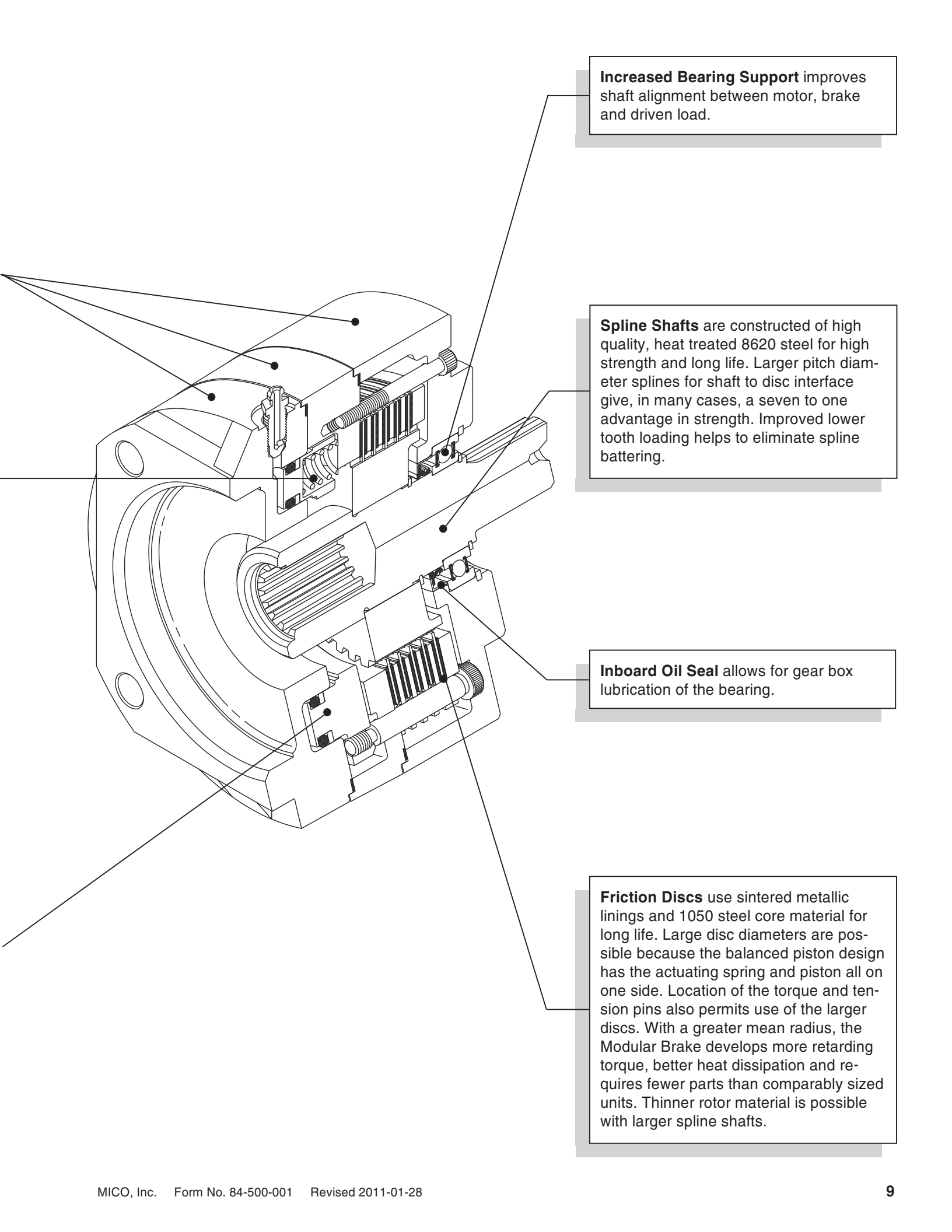

Increased Bearing Support improves shaft alignment between motor, brake and driven load.

Spline Shafts are constructed of high quality, heat treated 8620 steel for high strength and long life. Larger pitch diameter splines for shaft to disc interface give, in many cases, a seven to one advantage in strength. Improved lower tooth loading helps to eliminate spline battering.

Inboard Oil Seal allows for gear box lubrication of the bearing.

Friction Discs use sintered metallic linings and 1050 steel core material for long life. Large disc diameters are possible because the balanced piston design has the actuating spring and piston all on one side. Location of the torque and tension pins also permits use of the larger discs. With a greater mean radius, the Modular Brake develops more retarding torque, better heat dissipation and requires fewer parts than comparably sized units. Thinner rotor material is possible with larger spline shafts.



A-Mount Brakes, Modular Design



FEATURES

- Low release pressures - ideal for use with closed-loop hydrostatic systems
- Rugged heavy-duty construction with torques to 1017 N·m (9000 lb·in)
- Heat treated 8620 shafts for high strength and long life
- Unique balanced piston design

13-538-008
(3A-060640-M)

For detailed information on other model numbers go to
www.mico.com/service/it/drawing.php

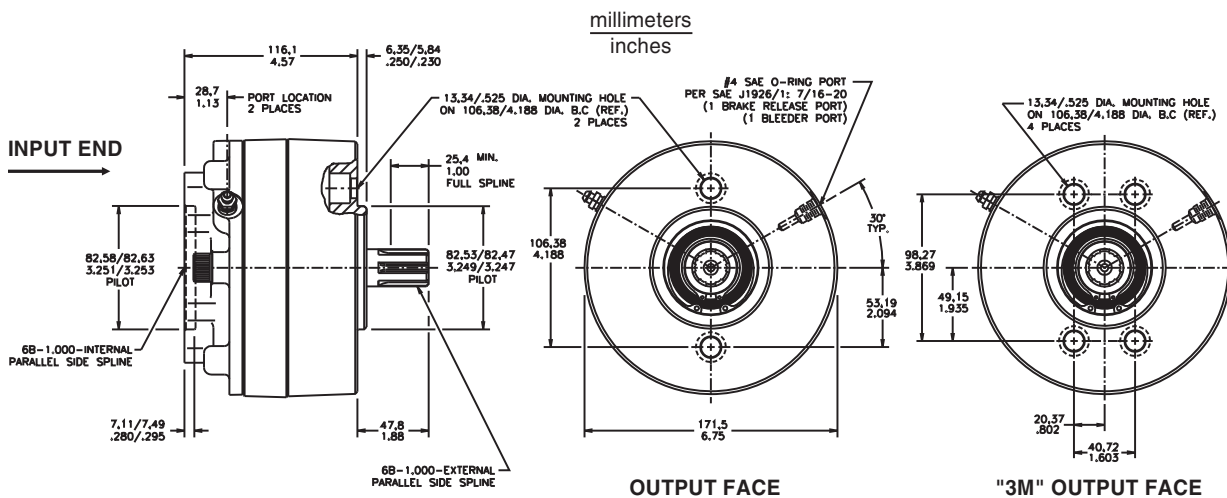

SPECIFICATIONS

Torque range at 0 bar (0 PSI)
back pressure 203 - 1017 N·m
(1800 - 9000 lb·in)

Release pressure range 8.3 - 26.9 bar (120 - 390 PSI)

Maximum operating pressure 206.8 bar (3000 PSI)

Maximum energy input 216,960 joule (160,000 ft·lb)
(one stop, no damage)

Volume of oil to release brake 8.2 cm³ (0.5 in³)

Maximum operating temperature 132 °C (270 °F)

Maximum speed 4000 RPM

Approximate weight 11 kg (24 lb)

Fluid type Mineral base hydraulic oil

CATALOG CODE (See NOTE on the top of page 6)

Not all of the brake combinations are possible due to certain design limitations.

NOTE: Dry design only, not for wet applications.



OUTPUT FACE

- 3A - SAE A-Mount
2-Bolt
- 3M - 4-Bolt A-Mount

OUTPUT SPLINE / INPUT SPLINE

	SAE Designation
06/06	06 = 25.4 mm (1.00 in) Diameter 6B
10/10	10 = 25.4 mm (1.00 in) Diameter Keyed
14/14	14 = 14T 12/24
25/25	25 = 31.8 mm (1.25 in) Diameter Keyed

For other configurations, consult a MICO Applications Specialist.

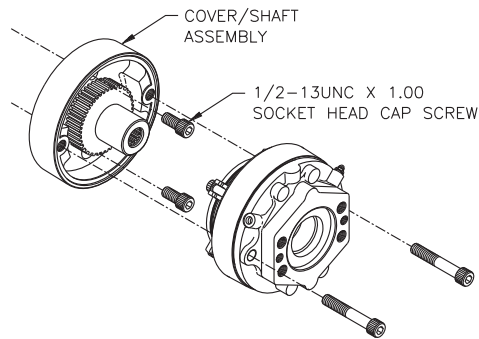

Mounting Instructions

Install cover/shaft assembly on gearbox using either two or four 1/2-13UNC x 1.00 inch long socket head cap screws (not included), depending on brake model being used. See Mounting Instructions (Form No. 81-538-002) included with each brake.

OPTIONS

(Available separately or in combination)
D - Double Bearing
S - Speed Sensor

INPUT FACE

M - 4-Bolt and SAE A-Mount 2-Bolt

TORQUE

Code	Torque Rating		Initial Release Pressure		Full Release Pressure	
	N-m	(lb-in)	bar	(PSI)	bar	(PSI)
90 *	1017	(9000)	22.8	(330)	26.9	(390)
70 *	791	(7000)	17.2	(250)	20.7	(300)
56 *	633	(5600)	14.5	(210)	17.2	(250)
48 *	542	(4800)	11.7	(170)	13.8	(200)
40	452	(4000) †	14.5	(210)	17.2	(250)
39	441	(3900)	10.3	(150)	12.4	(180)
35	396	(3500) †	11.7	(170)	13.8	(200)
34	384	(3400)	9.0	(130)	10.3	(150)
29	328	(2900) †	10.3	(150)	12.4	(180)
25	283	(2500) †	9.0	(130)	10.3	(150)
24	271	(2400)	6.9	(100)	8.3	(120)
18	203	(1800) †	6.9	(100)	8.3	(120)

* For use with input and output spline codes 14 and 25 only.
† Models available with speed sensor port.
Other torques and/or release pressures are available upon request.

Input Face

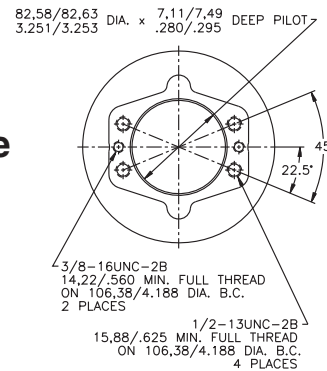

M - 4-Bolt and SAE A-Mount 2-Bolt

CATALOG CODE	MODEL NUMBER	CATALOG CODE	MODEL NUMBER
3A-060618-M	13-538-004	3A-141418-M	13-538-016
3A-060624-M	13-538-052	3A-141424-M	13-538-036
3A-060625-M	13-538-230	3A-141435-M	13-538-384
3A-060629-M	13-538-054	3A-141439-M	13-538-050
3A-060639-M	13-538-058	3A-141448-M	13-538-300
3A-060635-M	13-538-006	3A-141456-M	13-538-056
3A-060640-M	13-538-008	3A-141470-M	13-538-290
3A-060656-M	13-538-232	3A-141490-M	13-538-320
3A-100625-M	13-538-294	3A-141490-MD	13-538-034
3A-100640-M	13-538-044	3A-252518-M	13-538-178
3A-101018-M	13-538-010	3A-252524-M	13-538-376
3A-101025-M	13-538-196	3A-252525-M	13-538-022
3A-101029-M	13-538-024	3A-252529-M	13-538-274
3A-101035-M	13-538-026	3A-252535-M	13-538-370
3A-101040-M	13-538-012	3A-252540-M	13-538-242

CATALOG CODE	MODEL NUMBER	CATALOG CODE	MODEL NUMBER
3A-252548-M	13-538-272	3M-141456-M	13-538-234
3A-252556-M	13-538-028	3M-141470-M	13-538-236
3A-252590-M	13-538-060	3M-141470-MD	13-538-202
3M-060625-M	13-538-244	3M-141490-M	13-538-038
3M-060640-M	13-538-064	3M-252529-M	13-538-318
3M-101040-M	13-538-040	3M-252535-M	13-538-182
3M-141440-M	13-538-020	3M-252540-M	13-538-042
3M-141440-MD	13-538-032	3M-252556-M	13-538-382
3M-141448-M	13-538-046	3M-252590-M	13-538-048



C-Mount Brakes, Modular Design



FEATURES

- More retarding torque than competitive models
- Numerous mounting configurations available
- Low release pressures, ideal for use with closed-loop hydrostatic systems
- Rugged heavy-duty construction
- Heat treated 8620 shafts for high strength and long life
- Compact modular package simplifies mounting
- Unique balanced piston design

13-547-078
(3C-141455-CZ)

For detailed information on other model numbers go to
www.mico.com/servicelit/drawing.php

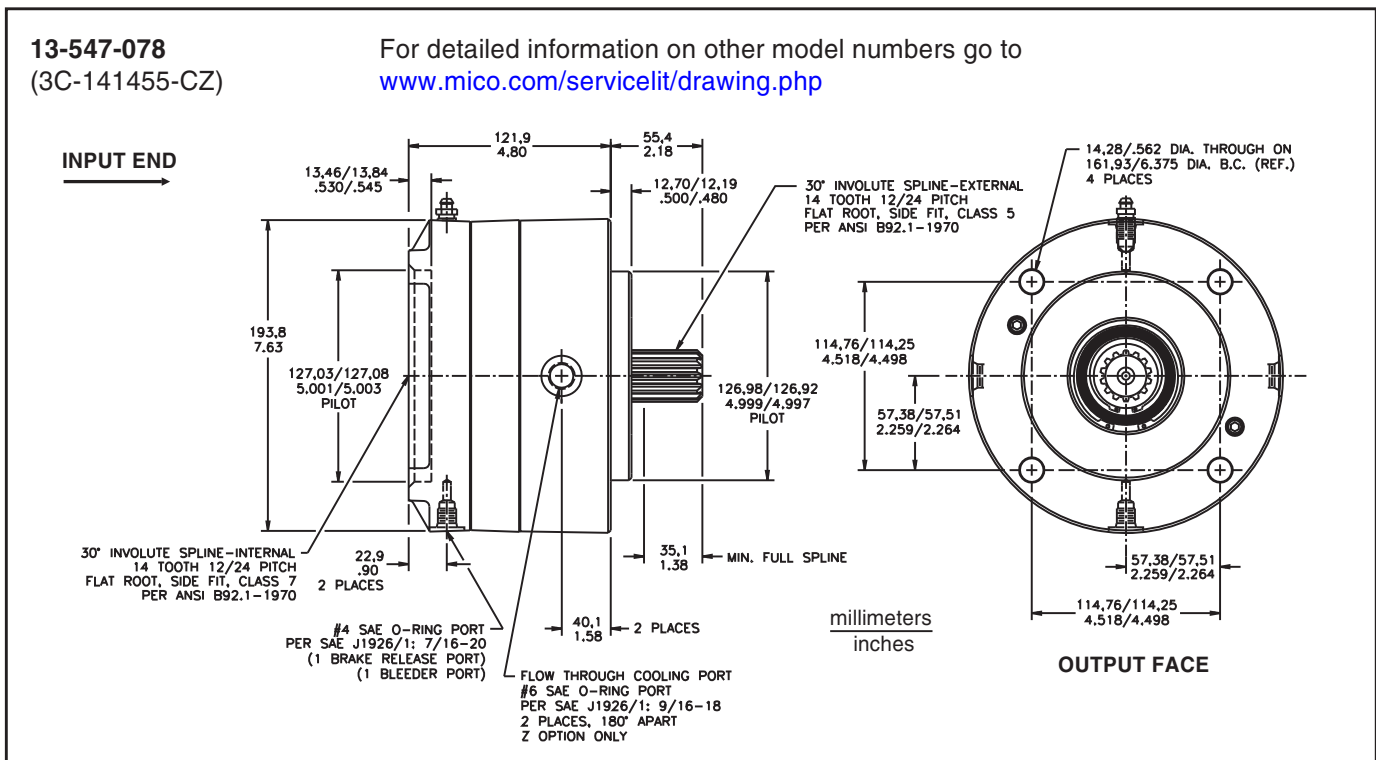

SPECIFICATIONS

Torque range at 0 bar (0 PSI)
back pressure 509 - 1356 N-m (2200 - 12,000 lb-in)
Release pressure range 10.3 - 21.4 bar (150 - 310 PSI)
Maximum operating pressure 206.8 bar (3000 PSI)
Maximum speed 4000 RPM
Volume of oil
to release brake 16.4 cm³ (1.0 in³)
Maximum operating temperature 132 °C (270 °F)
Maximum energy input 542,400 joule (400,000 ft-lb)
(one stop, no damage)

Approximate weight 18 kg (40 lb)
Fluid type Mineral base hydraulic oil

CATALOG CODE (See NOTE on the top of page 6)

Not all of the brake combinations are possible due to certain design limitations.

NOTE: On oil cooled models (Z option) actual torque is 67% of value shown on torque code chart. Recommended sump oil fluid volume when mounted: Horizontal - 118.3 mL (4 oz), Vertical - Contact MICO.



OUTPUT FACE

3C - SAE C-Mount
4-Bolt

OUTPUT SPLINE / INPUT SPLINE

	SAE Designation
04/00	00 = Used with "R" input face only
04/14	04 = 14T 12/24 (internal)
14/00	06 = 25.4mm (1.00 in) Diameter 6B
14/06	13 = 13T 8/16
14/13	13 = 13T 16/32
14/14	14 = 14T 12/24
14/17	17 = 17T 12/24
17/14	21 = 21T 16/32
17/17	25 = 31.8 mm (1.25 in) Diameter Keyed
21/00	
21/21	
25/14	

For other configurations, consult a MICO Applications Specialist.

OPTIONS

(Available separately or in combination)
D - Double Bearing
S - Speed Sensor
V - Fluorocarbon seals
Z - Oil Cooled - see note above

INPUT FACE

B - SAE B-Mount 2-Bolt
C - SAE C-Mount 4-Bolt
C2 - SAE C-Mount 2-Bolt Through
C24 - 2-Bolt and 4-Bolt C-Mount
D - SAE D-Mount
K4 - Eaton Standard 4000
M - 4-Bolt and SAE A-Mount 2-Bolt
R - Closed

See Page 46 for Input Face Dimensions.

TORQUE

Code	Torque Rating		Initial Release Pressure		Full Release Pressure	
	N-m	(lb-in)	bar	(PSI)	bar	(PSI)
98	1107	(9800)	14.5	(210)	20.0	(290)
85	960	(8500)	11.0	(160)	15.2	(220)
80	904	(8000)	12.4	(180)	17.2	(250)
70	791	(7000)	11.0	(160)	14.5	(210)
66	746	(6600)	9.0	(130)	12.4	(180)
55	622	(5500)	9.0	(130)	11.7	(170)
54	610	(5400)	7.6	(110)	11.0	(160)
45	508	(4500)	7.6	(110)	10.3	(150)
30	339	(3000)	4.1	(60)	6.2	(90)
28	316	(2800)	4.1	(60)	6.2	(90)
25	283	(2500)	6.9	(100)	9.0	(130)
24	271	(2400)	5.5	(80)	7.6	(110)
22	249	(2200)	2.8	(40)	4.1	(60)
16	1808	(16,000)	19.3	(280)	28.3	(410)
12	1356	(12,000)	14.5	(210)	21.4	(310)
10	1130	(10,000)	12.4	(180)	17.2	(250)

Other torques and/or release pressures are available upon request.

ASSIGNED NUMBERS

CATALOG CODE	MODEL NUMBER	CATALOG CODE	MODEL NUMBER
3C-040080-RZ	13-547-532	3C-141424-CZ	13-547-486
3C-041412-C	13-547-282	3C-141425-C	13-547-054
3C-041445-C	13-547-454	3C-141428-C	13-547-058
3C-041445-C2D	13-547-502	3C-141430-C	13-547-064
3C-041498-C	13-547-324	3C-141430-C24Z	13-547-544
3C-140012-R	13-547-272	3C-141445-C	13-547-072
3C-140012-RZ	13-547-420	3C-141445-CZ	13-547-362
3C-140016-RZ	13-547-510	3C-141445-C2Z	13-547-522
3C-140098-R	13-547-268	3C-141445-C24	13-547-424
3C-140612-MZ	13-547-370	3C-141445-K4	13-547-384
3C-140628-M	13-547-002	3C-141445-M	13-547-352
3C-140645-M	13-547-264	3C-141454-C	13-547-074
3C-140655-M	13-547-232	3C-141455-B	13-547-354
3C-140655-MZ	13-547-006	3C-141455-BZ	13-547-298
3C-140685-M	13-547-246	3C-141455-C	13-547-076
3C-140698-M	13-547-190	3C-141455-CD	13-547-344
3C-141324-B	13-547-252	3C-141455-CS	13-547-452
3C-141328-B	13-547-306	3C-141455-CZ	13-547-078
3C-141345-D	13-547-422	3C-141455-C24	13-547-492
3C-141355-B	13-547-290	3C-141455-M	13-547-364
3C-141380-D	13-547-410	3C-141466-C	13-547-082
3C-141398-D	13-547-016	3C-141466-CZ	13-547-474
3C-141398-DZ	13-547-434	3C-141466-C24	13-547-358
3C-141410-C	13-547-482	3C-141466-M	13-547-204
3C-141410-CZ	13-547-024	3C-141466-MZ	13-547-226
3C-141410-K4	13-547-164	3C-141470-C	13-547-084
3C-141410-M	13-547-026	3C-141470-CZ	13-547-086
3C-141412-C	13-547-030	3C-141480-B	13-547-342
3C-141412-CD	13-547-316	3C-141480-BZ	13-547-472
3C-141412-CDZ	13-547-288	3C-141480-C	13-547-090
3C-141412-CZ	13-547-034	3C-141445-C2	13-547-208
3C-141412-C24Z	13-547-022	3C-141480-K4	13-547-094
3C-141412-K4	13-547-296	3C-141480-K4Z	13-547-254
3C-141412-K4Z	13-547-036	3C-141480-M	13-547-096
3C-141412-M	13-547-038	3C-141485-C	13-547-098
3C-141422-C	13-547-046	3C-141498-C	13-547-102

CATALOG CODE	MODEL NUMBER	CATALOG CODE	MODEL NUMBER
3C-141498-C2	13-547-104	3C-171785-C	13-547-278
3C-141498-CS	13-547-106	3C-171785-CZ	13-547-126
3C-141498-CV	13-547-450	3C-171798-C	13-547-212
3C-141498-CZ	13-547-108	3C-212145-C	13-547-332
3C-141498-C24	13-547-396	3C-212145-CZ	13-547-526
3C-141498-C24Z	13-547-048	3C-212166-C	13-547-130
3C-141498-K4	13-547-110	3C-212180-C	13-547-132
3C-141498-M	13-547-116	3C-212185-C	13-547-220
3C-141498-MD	13-547-378	3C-212198-C	13-547-134
3C-141712-C	13-547-118	3C-251498-K4	13-547-334
3C-141724-CZ	13-547-464		
3C-141754-C	13-547-214		
3C-141755-C	13-547-120		
3C-141785-C	13-547-182		
C3-141798-C	13-547-294		
3C-171485-C	13-547-122		
3C-171712-C	13-547-462		
3C-171780-C	13-547-124		



D-Mount Brakes, Modular Design



FEATURES

- Oil cooled or dry design applications
- Simple four-bolt mounting configuration
- Low-release pressures, ideal for use with closed-loop hydrostatic systems
- Rugged heavy-duty construction
- Heat treated 8620 shafts for high strength and long life
- Unique balanced piston design

13-552-006
(3D-131312-DZ)

For detailed information on other model numbers go to
www.mico.com/servicelit/drawing.php

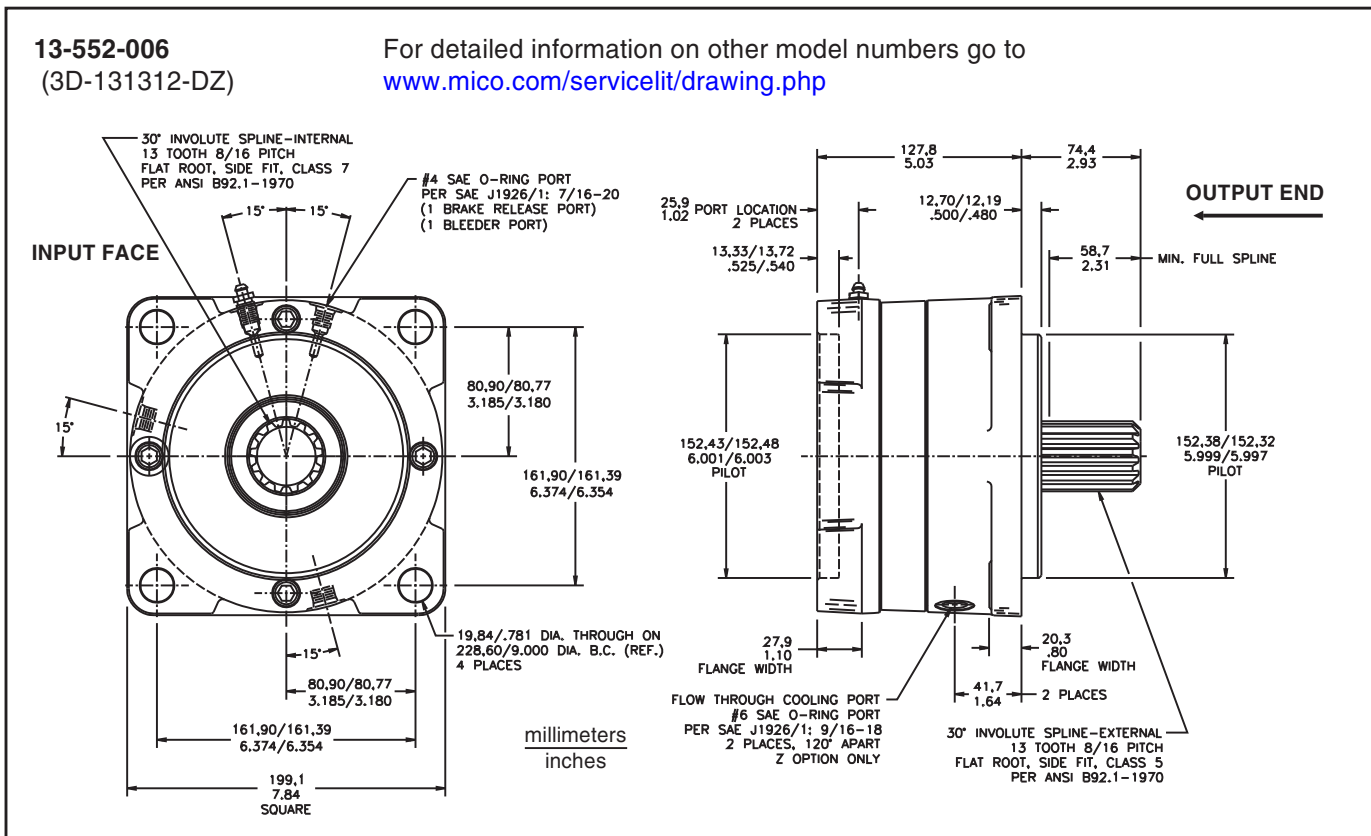

SPECIFICATIONS

Torque range at 0 bar (0 PSI)
back pressure 621 - 2712 N-m (5500 - 24,000 lb-in)
Release pressure range 7.6 - 26.9 bar (110 - 470 PSI)
Maximum operating pressure 206.8 bar (3000 PSI)
Maximum speed 4000 RPM
Volume of oil
to release brake 16.4 cm³ (1.0 in³)

Maximum energy input 610,200 joule (450,000 ft-lb)
(one stop, no damage)
Fluid type Mineral base hydraulic oil
Maximum operating temperature 132 °C (270 °F)
Approximate weight 24 kg (52 lb)

CATALOG CODE (See NOTE on the top of page 6)

Not all of the brake combinations are possible due to certain design limitations.

NOTE: On oil cooled models (Z option) actual torque is 67% of value shown on torque code chart. Recommended sump oil fluid volume when mounted: Horizontal - 147.9 mL (5 oz), Vertical - Contact MICO.



OUTPUT FACE

3D - SAE D-Mount
4-Bolt

OUTPUT SPLINE / INPUT SPLINE

13/00	SAE and DIN 5480 Designation
13/13	00 = Used with "R" input face only
13/14	13 = 13T 8/16
13/15	14 = 14T 12/24
13/16	15 = 15T 8/16
13/16	16 = 16T 8/16
13/21	21 = N45 x 2 x 21 x 9H
75/75	75 = 44.5 mm (1.75 in) Diameter Keyed

OPTIONS

Z - Oil Cooled - see note above

INPUT FACE

C - SAE C-Mount
D - SAE D-Mount
E - SAE E-Mount
R - Closed Face

TORQUE

Code	Torque Rating		Initial Release Pressure		Full Release Pressure	
	N-m	(lb-in)	bar	(PSI)	bar	(PSI)
80	904	(8000)	9.0	(130)	11.7	(170)
55	621	(5500)	5.5	(80)	7.6	(110)
24	2712	(24,000)	22.8	(330)	32.4	(470)
20	2260	(20,000)	18.6	(270)	26.2	(380)
16	1808	(16,000)	14.5	(210)	20.7	(300)
12	1356	(12,000)	11.0	(160)	15.9	(230)
10	1130	(10,000)	10.3	(150)	13.8	(200)

For other configurations, consult a MICO Applications Specialist.

Other torques and/or release pressures are available upon request.

ASSIGNED NUMBERS

CATALOG CODE	MODEL NUMBER	CATALOG CODE	MODEL NUMBER
3D-130020-RZ	13-552-068	3D-131380-DZ	13-552-036
3D-130024-R	13-552-076	3D-131380-E	13-552-044
3D-131310-D	13-552-040	3D-131416-C	13-552-094
3D-131310-E	13-552-042	3D-131424-CZ	13-552-102
3D-131312-D	13-552-002	3D-131480-C	13-552-038
3D-131312-DZ	13-552-006	3D-131512-E	13-552-078
3D-131316-C	13-552-016	3D-131512-EZ	13-552-104
3D-131316-D	13-552-008	3D-131516-E	13-552-090
3D-131320-D	13-552-060	3D-131524-EZ	13-552-106
3D-131324-D	13-552-070	3D-131624-C	13-552-080
3D-131324-DZ	13-552-086	3D-132112-D	13-552-054
3D-131355-D	13-552-012	3D-757512-DZ	13-552-028
3D-131380-D	13-552-033		

Input Faces

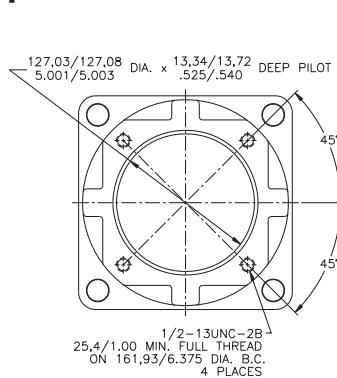

C - SAE C-Mount

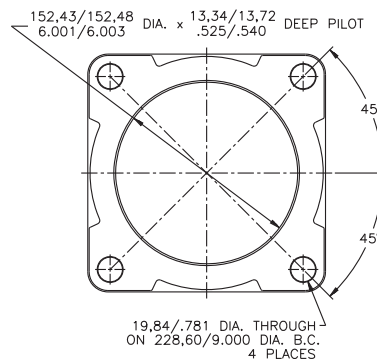

D - SAE D-Mount

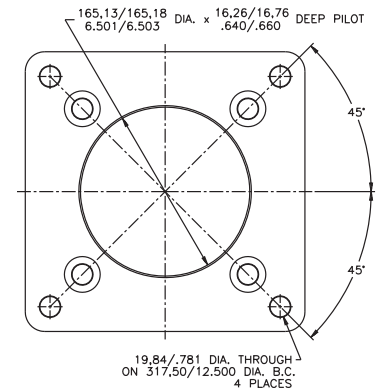

E - SAE E-Mount



Multiple Disc Brakes, Narrow Design

Features

- Complete self-contained package
- Standard SAE mounting flanges
- Spring loaded, hydraulically released
- High-strength ductile iron construction
- Sealed environment - isolation from contaminants

Benefits

- Thick discs eliminate tooth wear-out and brake "freewheeling," resulting in longer life between parts replacement
- Large inlet port helps avoid sluggish response if air is entrapped in the oil
- One piece separator design helps eliminate breaking and bending moments on piston, resulting in minimal loss because of good contact on plates
- Longer dowel pins simplify assembly and keep rotor in place, reducing risk of shearing teeth from rotor

Operation

Braking using this version is provided by a pack of rotating friction discs splined to the shaft and stationary separator plates restrained by pins in the housing. Force is transmitted to the disc pack through the return plate by a series of preloaded springs. The brakes are released by hydraulic pressure applied to the piston to compress the springs. They are self-applying since any function which reduces the hydraulic pressure below the release pressure will start to initiate a brake application. Zero pressure produces maximum brake torque.

Cover Bolts are high-strength SAE grade 8 flanged type, which allow for higher brake release pressure shocks without subsequent cover bolt damage.

O-ring and Back-up Ring combination on all models.

Housings are constructed of high quality ductile iron castings for strength and durability.

Piston Separator design allows for easier disassembly and assembly. This one piece powdered metal design as opposed to a split piston design, helps eliminate breaking and bending moments on piston.

Chrome Silicon Die Springs provide higher torque capabilities where space is limited, resulting in longer service life.

Spline Shafts are constructed of high-quality, heat-treated 8620 steel for high strength and long life. The precision ground one-piece spline shafts reduce vibration.

Rotary Shaft Seal at output end to prevent oil and other contaminants from entering brake.

Friction Discs use sintered metallic linings and high strength 1050 steel core material for long life.



B-Mount Brakes, Narrow Design



FEATURES

- Complete self-contained dry design package
- Standard SAE mounting flanges
- High-strength ductile iron castings for strength and durability
- Sintered bronze or non-metallic friction plates for high strength and long lining life
- Sealed environment - isolated from contaminants
- Optional pressure override models available for limited service braking

02-556-326
(LMB-131321-B)

For detailed information on other model numbers go to
www.mico.com/servicelit/drawing.php

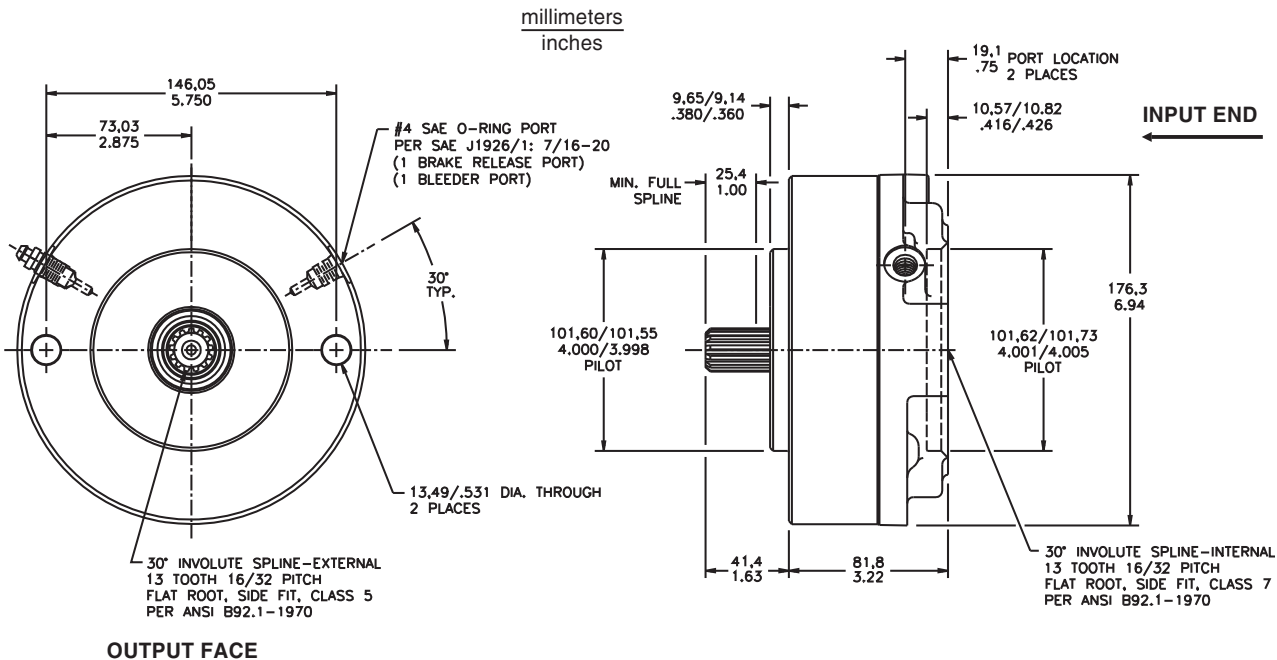

SPECIFICATIONS

Torque range at 0 bar (0 PSI)
 back pressure 113 - 542 N-m (700 - 6000 lb-in)
 Release pressure range 8.3 - 23.8 bar (120 - 345 PSI)
 Maximum operating pressure 206.8 bar (3000 PSI)
 Maximum speed 4000 RPM
 Volume of oil
 to release brake 8.2 cm³ (0.5 in³) (new linings)
 14.8 cm³ (0.9 in³) (maximum)
 Maximum energy input 339,000 joule (250,000 ft-lb)
 (one stop, no damage)

Fluid type Mineral base hydraulic oil
 Maximum operating temperature 132 °C (270 °F)
 Approximate weight 10.9 kg (24 lb)

Optional pressure override section
 Service torque rating 305 N-m @ 69.0 bar
 (2700 lb-in @ 1000 PSI)
 Maximum input pressure 69.0 bar (1000 PSI)

CATALOG CODE (See NOTE on the top of page 6)

Not all of the brake combinations are possible due to certain design limitations.

NOTE: On oil cooled models (Z option) actual torque is 67% of value shown on torque code chart. Recommended sump oil fluid volume when mounted: Horizontal - 88.7 mL (3 oz), Vertical - Contact MICO.



SERIES

LM - MICO

OUTPUT FACE

B - SAE B-Mount 2-Bolt

OUTPUT SPLINE / INPUT SPLINE

	SAE Designation
06/06	06 = 25.4 mm (1.00 in) Diameter 6B
13/06	12 = 12T 12/24 used with L2 input face only
13/12	13 = 13T 16/32
13/13	14 = 14T 12/24
14/13	15 = 15T 16/32
15/12	
15/15	

For other configurations, consult a MICO Applications Specialist.

OPTIONS

(Available separately or in combination)

- P - Pressure Override
- S - Speed Sensor
- Z - Oil Cooled - see note above

INPUT FACE

- B - SAE B-Mount 2-Bolt
- L2 - Eaton Bearingless 2000
- M - Modified SAE A-Mount 2 or 4-Bolt
- N - NEMA

See Page 47 for Input Face Dimensions

TORQUE

Code	Torque Rating	Initial Release Pressure		Full Release Pressure	
		bar	(PSI)	bar	(PSI)
60	678 (6000)	23.1	(335)	27.6	(400)
51	576 (5100)	20.0	(290)	23.4	(340)
50	565 (5000)	22.1	(320)	27.6	(400)
48	542 (4800)	17.9	(260)	21.4	(310)
40	452 (4000)	15.2	(220)	17.9	(260)
35	396 (3500)	20.0	(290)	23.8	(345)
30	339 (3000)	16.5	(240)	20.0	(290)
29	328 (2900)	11.0	(160)	15.9	(230)
28	316 (2800)	15.9	(230)	19.3	(280)
24	271 (2400)	12.4	(180)	15.2	(220)
21	237 (2100)	12.4	(180)	14.5	(210)
19	215 (1900)	11.7	(170)	13.8	(200)
17	192 (1700)	9.7	(140)	11.7	(170)
16	181 (1600)	7.9	(115)	9.3	(135)
15	170 (1500)	7.2	(105)	7.9	(115)
14	158 (1400)	8.3	(120)	10.0	(145)
12	136 (1200)	13.8	(200)	16.2	(235)
11	124 (1100)	9.3	(135)	11.0	(160)
10	113 (1000)	11.7	(170)	13.8	(200)
08	90 (800)	7.2	(105)	7.9	(115)
07	79 (700)	3.4	(50)	4.1	(60)

NOTE: MICO recommends that all applications for pressure override brakes have a completed Data Sheet submitted to the MICO Application Department. Complete the online Application Data Sheet (80-500-010) at www.mico.com/datasheets/DataSheetCover.pdf.

Other torques and/or release pressures are available upon request.

ASSIGNED NUMBERS

CATALOG CODE	MODEL NUMBER	CATALOG CODE	MODEL NUMBER
LMB-060651-B	02-556-420	LMB-131317-B	02-556-332
LMB-130614-M	02-556-304	LMB-131321-B	02-556-326
LMB-130616-MP	02-556-434	LMB-131324-B	02-556-360
LMB-130621-M	02-556-328	LMB-131328-B	02-556-324
LMB-130628-M	02-556-378	LMB-131329-BS	02-556-418
LMB-130635-M	02-556-336	LMB-131330-B	02-556-320
LMB-130640-M	02-556-358	LMB-131335-B	02-556-334
LMB-131219-L2	02-556-348	LMB-131340-B	02-556-376
LMB-131228-L2	02-556-350	LMB-141360-M	02-556-422
LMB-131240-L2	02-556-352	LMB-151240-L2	02-556-428
LMB-131308-N	02-556-406	LMB-151250-L2	02-556-454
LMB-131310-B	02-556-322	LMB-151507-B	02-556-432
LMB-131311-NS	02-556-390	LMB-151528-B	02-556-404
LMB-131312-B	02-556-330	LMB-151535-B	02-556-340
LMB-131314-B	02-556-318	LMB-151540-B	02-556-392
LMB-131315-BP	02-556-398		



Multiple Disc Brakes, Compact Design

Features

- Non-metallic lining material
- Extreme compact design
- Low release pressures
- Full system pressure capacity
- Low actuation volume

Integrated return plate/separators help prevent piston cocking.

Benefits

- Design allows for pressure spikes of up to 275.8 bar (4000 PSI) without affecting cycle life
- One repair kit for all serviceable parts
- Non-metallic lining material contributes to high torque and low release pressure

Operation

Braking is provided by stationary friction plates and a rotating disc splined to the shaft. Force is transmitted to the disc pack through the return plate by a series of preloaded springs. The brake is released by hydraulic pressure applied to the piston to compress the springs. The brake is self-applying since any function which reduces the hydraulic system pressure of the brake will start to initiate a brake application. Zero pressure produces maximum brake torque.

High quality ductile iron casting material for strength and durability.

Gasket design and high-strength bolts provide high pressure capability and long life.

8620 alloy steel shafts are heat treated for strength and shock resistance.

High performance non-metallic lining materials contribute to high torque, low release pressure.

Chrome silicon die springs for long life and high torque.

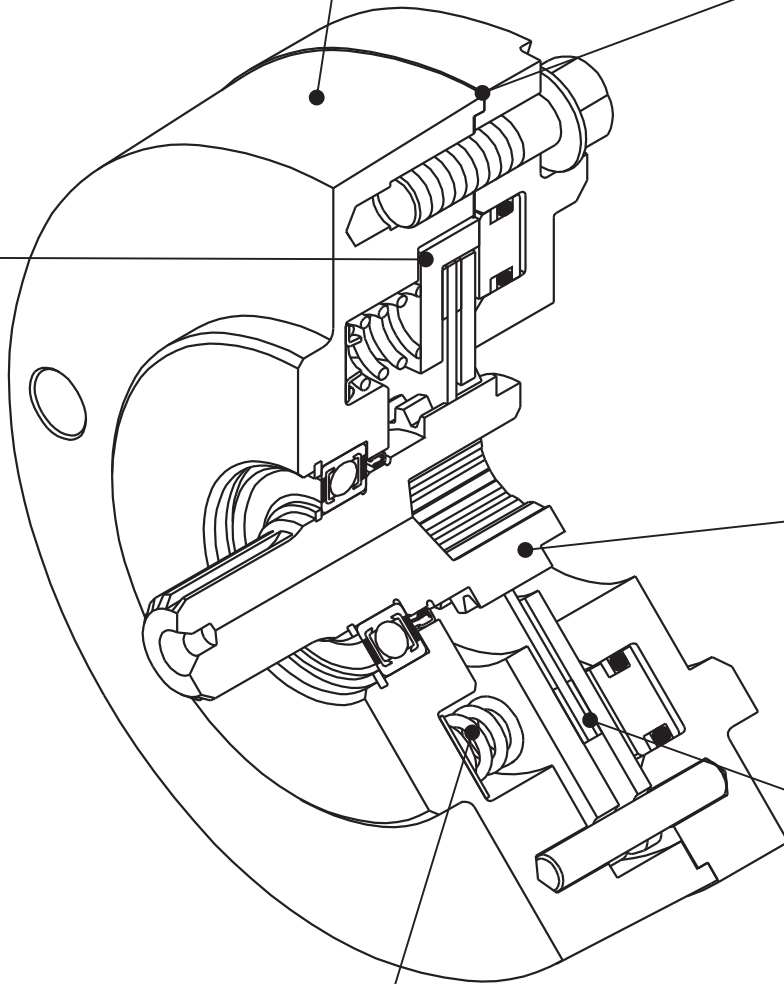



B-Mount Multiple Disc Brakes, Compact Design



FEATURES

- Non-metallic lining material
- Extremely compact package length
- Low release pressures - ideal for use with closed-loop hydraulic systems
- Full system pressure capacity
- Low actuation volume needed

13-100-002
(GB-131312-B)

For detailed information on other model numbers go to
www.mico.com/servicelit/drawing.php

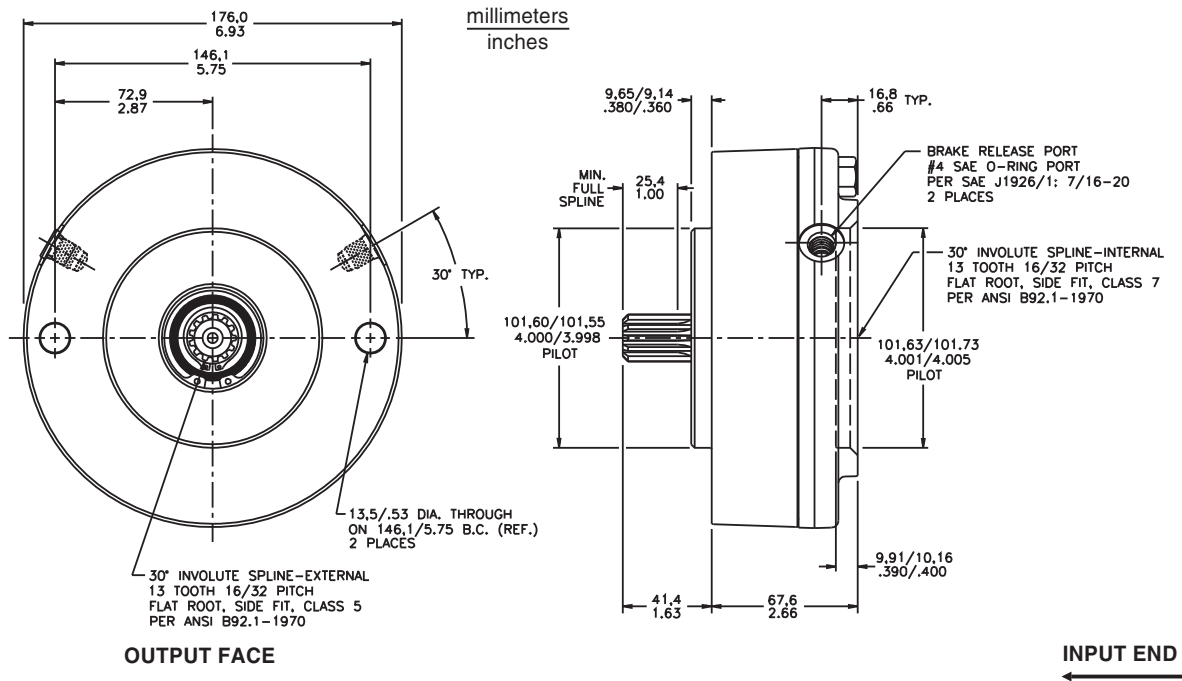

SPECIFICATIONS

Torque range at 0 bar (0 PSI)
back pressure 136 - 452 N-m (1200 - 6000 lb-in)
Release pressure range 6.9 - 20.0 bar (100 - 290 PSI) initial
7.9 - 23.4 bar (115 - 340 PSI) full
Maximum operating pressure 206.8 bar (3000 PSI) continuous
Maximum speed 4000 RPM shaft speed capability specified
is for brake in released condition.
Energy absorption during apply cycle must
be carefully examined for each application.

Volume of oil to release brake 8.2 cm³ (0.5 in³) minimum
14.8 cm³ (0.9 in³) maximum
Maximum energy input 231,000 joule (170,385 ft-lb)
Spline shaft 30° involute, flat root side fit
per ANSI B92.1 - 1970
Fluid type Mineral base hydraulic oil
Maximum operating temperature 132 °C / 270 °F
Approximate weight 10.3 kg (19 lb)

CATALOG CODE (See NOTE on the top of page 6)

Not all of the brake combinations are possible due to certain design limitations.

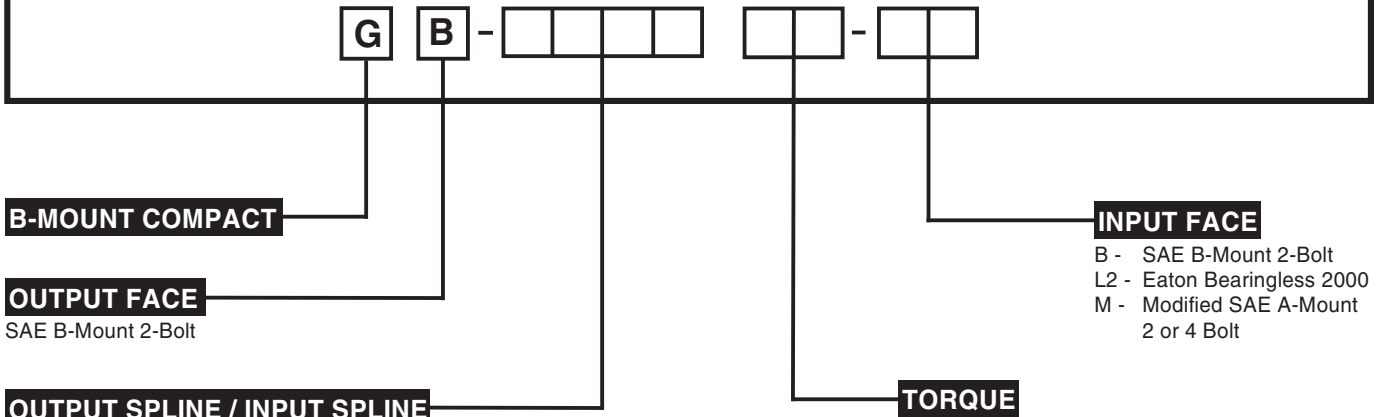

OUTPUT SPLINE / INPUT SPLINE

Code	SAE Designation
06/06	06 = 25.4 mm (1.00 in) Diameter 6B
13/06	12 = 12T 12/24 used with L2 input face only
13/13	13 = 13T 16/32
14/12	14 = 14T 12/24
14/14	15 = 15T 16/32
15/12	

For other configurations, consult a MICO Applications Specialist.

TORQUE

Code	Torque Rating		Initial Release Pressure		Full Release Pressure	
	N-m	(lb-in)	bar	(PSI)	bar	(PSI)
60*	678	(6000)	26.2	(380)	30.3	(440)
51	576	(5100)	22.1	(320)	25.2	(365)
50	565	(5000)	21.4	(310)	26.2	(380)
48	542	(4800)	20.7	(300)	23.8	(345)
40	452	(4000)	20.0	(290)	23.4	(340)
35	396	(3500)	16.5	(240)	19.3	(280)
28	316	(2800)	13.8	(200)	16.2	(235)
24	271	(2400)	13.1	(190)	14.8	(215)
21	237	(2100)	11.3	(165)	13.1	(190)
16	181	(1600)	8.6	(125)	10.0	(145)
14	158	(1400)	7.6	(110)	8.6	(125)
12	136	(1200)	6.9	(100)	7.9	(115)

* For use with input and output spline code 14 only.

Other torques and/or release pressures are available upon request.

ASSIGNED NUMBERS

CATALOG CODE	MODEL NUMBER	CATALOG CODE	MODEL NUMBER
GB-060628-B	13-100-046	GB-131335-B	13-100-012
GB-060635-B	13-100-054	GB-131340-B	13-100-014
GB-130648-M	13-100-040	GB-131351-M	13-100-018
GB-131312-B	13-100-002	GB-141260-L2	13-100-044
GB-131314-B	13-100-004	GB-141460-M	13-100-020
GB-131316-B	13-100-006	GB-151250-L2	13-100-048
GB-131321-B	13-100-024		
GB-131324-B	13-100-022		
GB-131328-B	13-100-010		

Input Faces

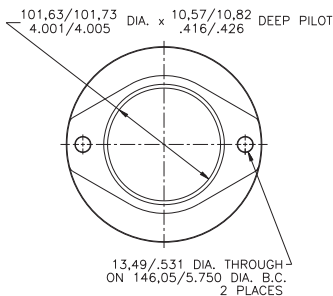

B - SAE B-Mount 2-Bolt

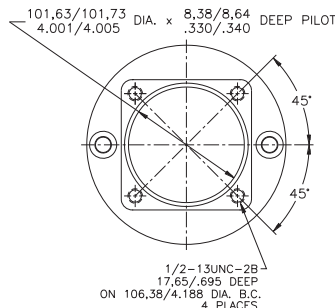

L2 - Eaton Bearingless 2000

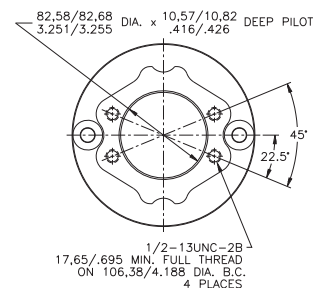

M - Modified SAE A-Mount 2-Bolt or 4-Bolt



Closed Output Motor Brakes

CATALOG CODE (See NOTE on the top of page 6)

Not all of the brake combinations are possible due to certain design limitations.

NOTE: Dry design only, not for wet applications.



FEATURES

- Mates with Parker Nichols & Sauer Danfoss through-shaft motors
- Low cost with high torque capacity

THROUGH-SHAFT BRAKE PRODUCT CODE

MN -Parker Nichols Series 110A
(also former Nichols Series 100, 110, 120, 130)
MS - Sauer Danfoss

INPUT SPLINE

13 - 13T 16/32
For other configurations, consult a MICO Applications Specialist.

INPUT FACE

M35 - Sauer Danfoss 5.75 inch B.C.
M46 - Sauer Danfoss 6.125 inch B.C.

TORQUE

Code	Torque Rating		Initial Release Pressure		Full Release Pressure	
	N-m	(lb-in)	bar	(PSI)	bar	(PSI)
56	633	(5600)	20.0	(290)	25.5	(370)
42	475	(4200)	15.9	(230)	20.7	(300)
35	396	(3500)	12.4	(180)	16.5	(240)
25	282	(2500)	8.3	(120)	10.3	(150)

Other torques and/or release pressures are available upon request.

02-550-116
(MN-1356)

For detailed information on other model numbers go to www.mico.com/servicelit/drawing.php

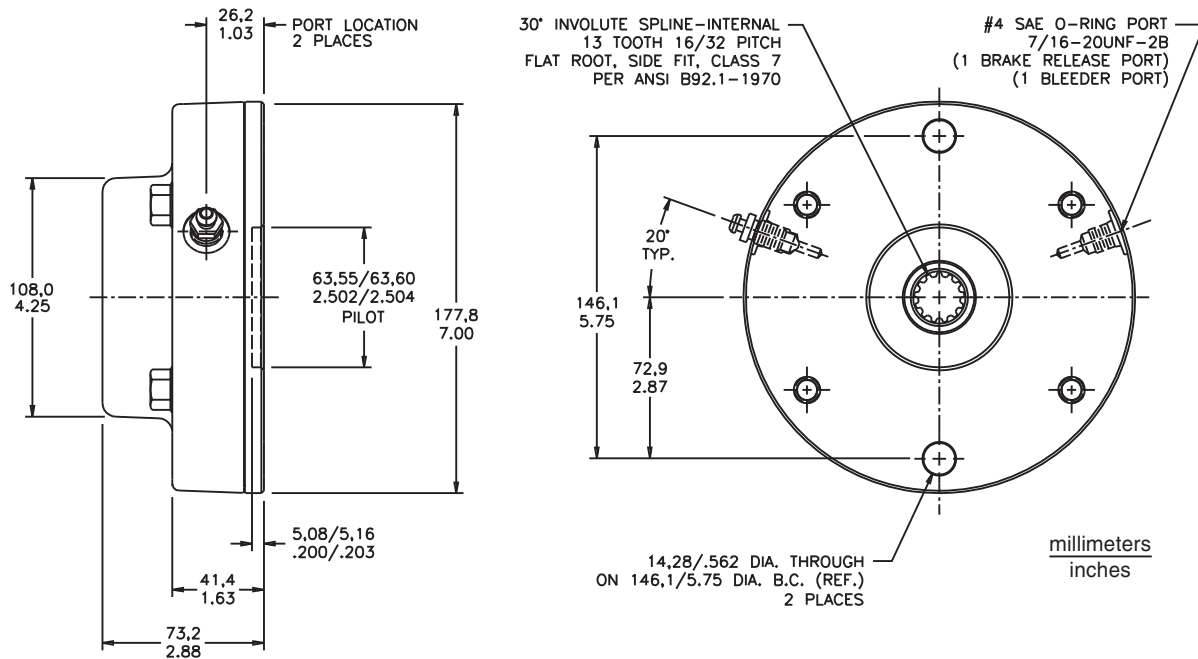

SPECIFICATIONS

Torque rating at 0 bar (0 PSI)
back pressure 283 - 633 N-m (2500 - 5600 lb-in)
Release pressure range 10.3 - 25.5 bar (150 - 370 PSI)
Maximum operating pressure 206.8 bar (3000 PSI)
Maximum speed 1000 RPM (MN)
4000 RPM (MS)

Volume of oil
to release brake 7.4 cm³ (0.45 in³)
Maximum operating temperature 132 °C (270 °F)
Approximate Weight 8.2 kg (18 lb)
Fluid type Mineral base hydraulic oil
Maximum energy input 135,600 joule (100,000 ft-lb)

ASSIGNED NUMBERS

CATALOG CODE	MODEL NUMBER
MN-1325	02-550-120
MN-1335	02-550-122
MN-1342	02-550-114
MN-1356	02-550-116
MS-1325-M35	02-550-124
MS-1325-M46	02-550-118



Posi-Torque Winch Brakes

The compact size of these MICO® Posi-Torque Winch Brakes permit easy installation into restricted space without requiring special adjustment, alignment, shims or brackets. Large diameter friction discs are possible because of the location of the tension pins. With these large discs the posi-torque brake develops more retarding torque than comparable sized units. The balanced piston design keeps critical components in tension when the brake is engaged. This helps eliminate bending or fracturing due to stress.

If winching is the application, a MICO® Spring Apply, Hydraulic Release, Multiple Disc Brake with posi-torque option is the ideal choice. This brake is designed primarily for use on a hydraulically driven winch system. It combines the benefits of allowing one-way winching, positive load positioning and “run-away” protection all in a single, compact package.

Quality pays in performance and reliability

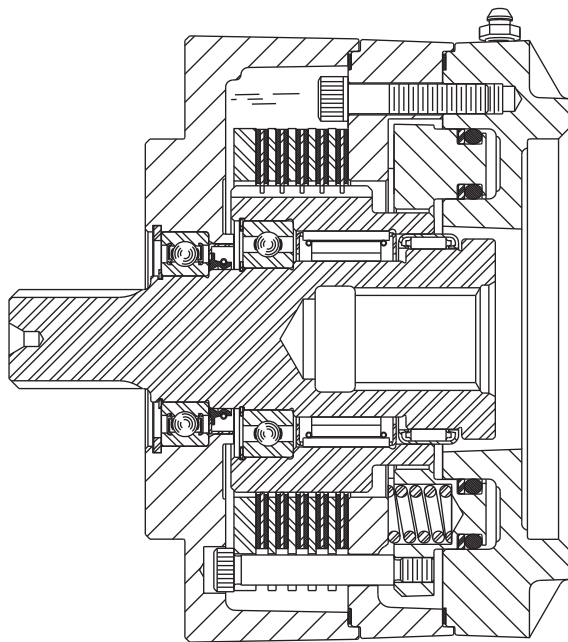

LUBRICATION

Oils containing slippery or antiwear additives, such as graphite or molybdenum disulfide or extreme pressure (EP) type lubricants, may allow the brake to slip at torque levels below the rated values and should be avoided.

MICO recommends a good grade of ATF, SAE 10 or SAE 20 oil, or Mobil DTE; also oils meeting MIL.7808 or MIL.23699.

MICO, Inc. Form No. 84-500-001 Revised 2011-01-28

Benefits

THE BRAKE "FREEWHEELS" IN THE LIFT DIRECTION

The MICO® Posi-Torque Brake is engaged while the load is being raised. The brake's internal over-riding clutch "freewheels" allowing travel in only one direction.

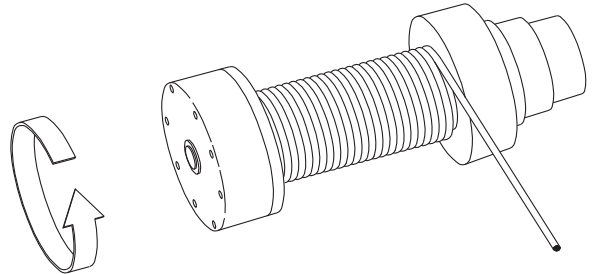

A ONE-WAY POSITIVE POSITIONING WINCH BRAKE

Once the winch stops lifting, the Posi-Torque Brake automatically holds the load in the desired position. Positive load positioning is immediately available because the brake is always engaged. There is no lag time or drift.

SAFE, RUNAWAY PROTECTION WHEN LOWERING THE LOAD

When lowering a load, hydraulic pressure disengages the Posi-Torque Brake. The load can be “powered” down using the winch’s hydraulic motor for safe, slow descent. If hydraulic pressure drops and the load begins to runaway from the motor, the MICO® Posi-Torque Brake automatically engages to bring the load to a safe controlled stop.

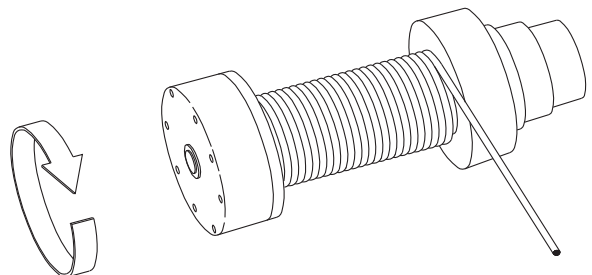



C-Mount Posi-Torque Brakes, Modular Design



FEATURES

- Wet design brake
- Nitrile case seals
- Positions the load at the instant the winch stops
- Compact size for easy installation
- Large-diameter discs
- Metallic linings for long life
- Hardened high-strength steel shafts
- Balanced piston design

13-602-006
(3CWC-141480-CCC)

For detailed information on other model numbers go to
www.mico.com/servicelit/drawing.php

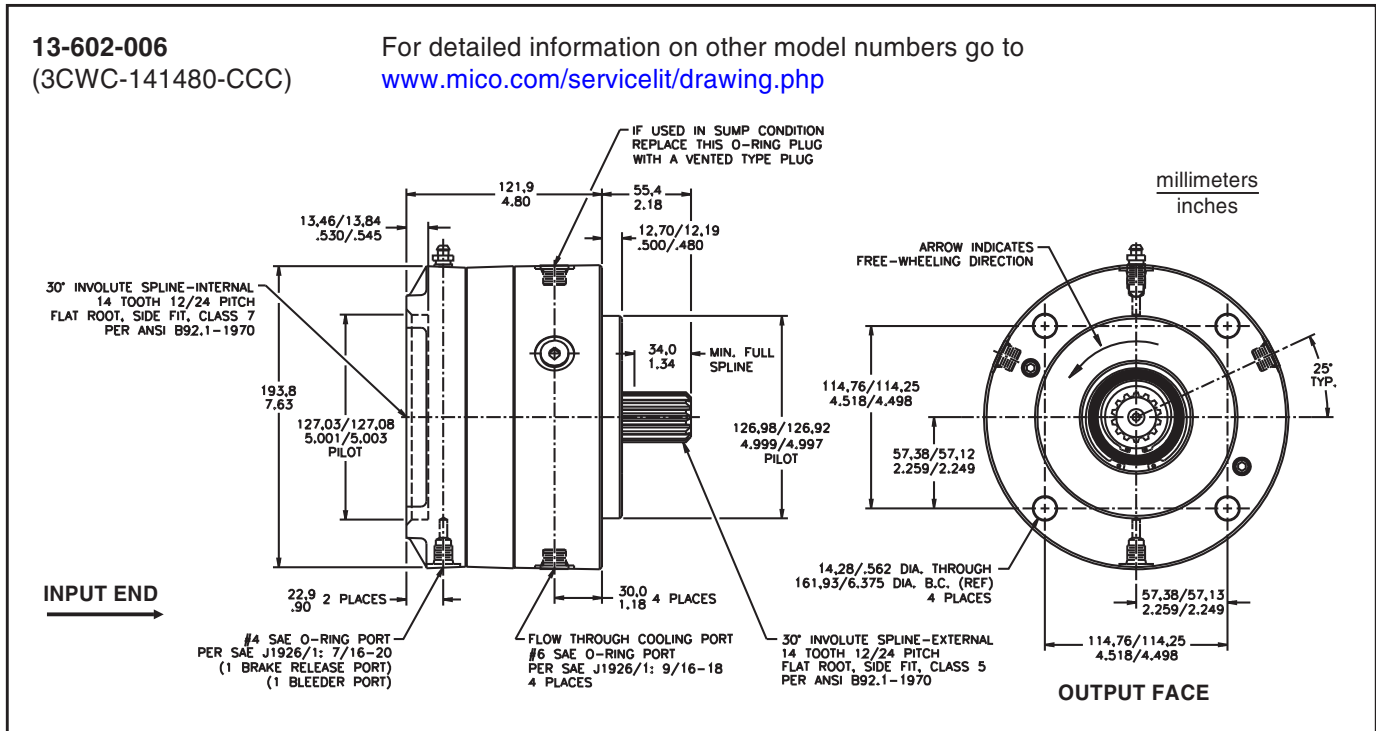

SPECIFICATIONS

Torque range at 0 bar (0 PSI)
back pressure Oil cooled operation
452 - 904 N-m (4000 - 8000 lb-in)

Release pressure range 13.1 - 25.5 bar (190 - 370 PSI)

Maximum operating pressure 206.8 bar (3000 PSI)

Maximum speed
(Non-freewheeling direction) (Flow through) 4000 RPM
(Sump) 3000 RPM
(Freewheeling direction) (Flow through) 4000 RPM
(Sump) 4000 RPM

Optimal flow through cooling 3.8 - 26.5 L/min (1 - 7 GPM)

Maximum case pressure 2.1 bar (30 PSI)

Sump cooling fluid volume 177.4 mL (6 oz)

Volume of oil
to release brake 16.4 cm³ (1.0 in³)

Maximum energy input 542,400 joule (400,000 ft-lb)
(one stop, no damage)

Fluid type Mineral base hydraulic oil

Maximum operating temperature 132 °C (270 °F)

Approximate weight 19 kg (42 lb)

CATALOG CODE (See NOTE on the top of page 6)

Not all of the brake combinations are possible due to certain design limitations.

NOTE: Wet design only, not intended for dry applications. To be installed in horizontal position only.



**3CW - C-MOUNT
POSI-TORQUE
WINCH BRAKE**

OUTPUT FACE

C - SAE C-Mount
4-Bolt

OUTPUT SPLINE / INPUT SPLINE

04/14 SAE Designation
14/14 04 = 14T 12/24 (internal)
 14 = 14T 12/24

For other configurations, consult a MICO Applications Specialist.

**FREEWHEELING
DIRECTION CODE**

(As you face the output end of brake)
CC - Counter Clockwise
CW - Clockwise

INPUT FACE

C - SAE C-Mount 4-Bolt
C24 - 2-Bolt and 4-Bolt C-Mount
K4 - Eaton Standard 4000
M - 4-Bolt and SAE A-Mount 2-Bolt

See Page 47 for Input Face Dimensions

TORQUE

Code	Torque Rating		Initial Release Pressure		Full Release Pressure	
	N-m	(lb-in)	bar	(PSI)	bar	(PSI)
80	904	(8000)	18.6	(270)	25.5	(370)
75	848	(7500)	17.2	(250)	22.7	(330)
70	791	(7000)	15.8	(230)	21.4	(310)
65	734	(6500)	15.2	(220)	20.7	(300)
40	452	(4000)	9.6	(140)	13.1	(190)

NOTE: Torque is coded as wet use.

Other torques and/or release pressures are available upon request.

ASSIGNED NUMBERS

CATALOG CODE	MODEL NUMBER
3CWC-041440-CCW	13-602-046
3CWC-041475-CCW	13-602-002
3CWC-141440-CCC	13-602-022
3CWC-141440-C24CC	13-602-030
3CWC-141440-C24CW	13-602-032
3CWC-141465-CCC	13-602-010
3CWC-141465-CCW	13-602-012
3CWC-141465-MCC	13-602-024
3CWC-141465-MCW	13-602-020
3CWC-141475-CCW	13-602-034
3CWC-141480-CCC	13-602-006
3CWC-141480-CCW	13-602-008
3CWC-141480-MCC	13-602-018

CATALOG CODE (See NOTE on the top of page 6)

Not all of the brake combinations are possible due to certain design limitations.

NOTE: On oil-cooled models (Z option) actual torque is 67% of value shown on torque code chart.

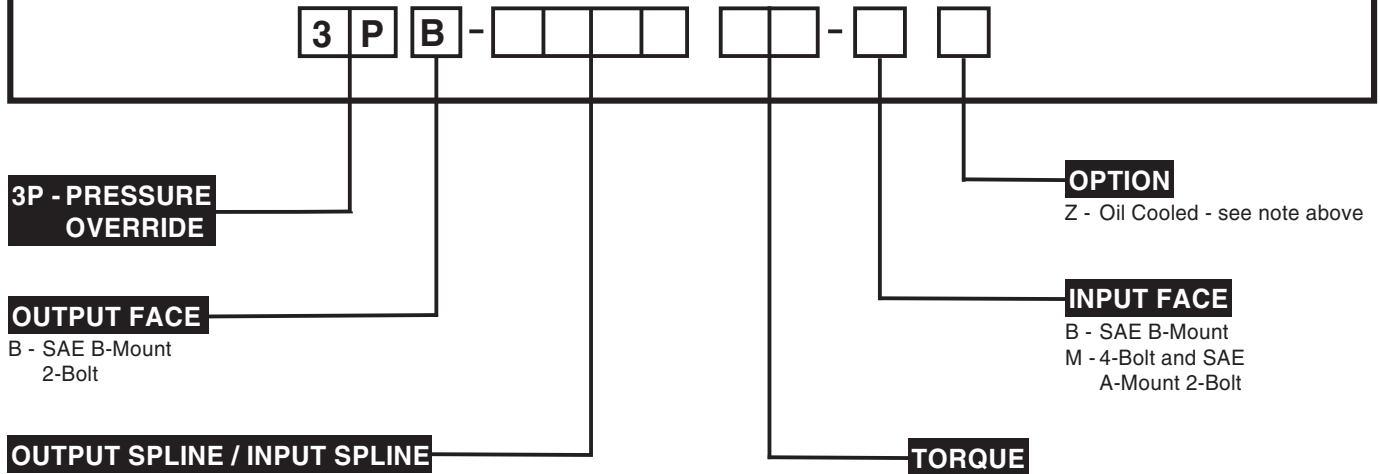

**3P - PRESSURE
OVERRIDE**

OUTPUT FACE

B - SAE B-Mount
2-Bolt

OUTPUT SPLINE / INPUT SPLINE

	SAE Designation
13/06	06 = 25.4 mm (1.00 in) Diameter 6B
13/13	13 = 13T 16/32
15/15	15 = 15T 16/32

For other configurations, consult a MICO Applications Specialist.

NOTE: MICO recommends that all applications for pressure override brakes have a completed Data Sheet submitted to the MICO Application Department. Complete the online Application Data Sheet (80-500-010) at www.mico.com/datasheets/DataSheetCover.pdf.

OPTION

Z - Oil Cooled - see note above

INPUT FACE

B - SAE B-Mount
M - 4-Bolt and SAE
A-Mount 2-Bolt

TORQUE

Code	Torque Rating	Initial Release Pressure	Full Release Pressure
	N-m (lb-in)	bar (PSI)	bar (PSI)
60 *	678 (6000)	20.0 (290)	24.1 (350)
52 *	588 (5200)	17.2 (250)	20.7 (300)
40	452 (4000)	13.8 (200)	16.5 (240)
35	396 (3500)	12.4 (180)	14.5 (210)
28	316 (2800)	9.6 (140)	11.7 (170)
24	271 (2400)	8.3 (120)	10.3 (150)
19	215 (1900)	7.6 (110)	9.0 (130)
16	181 (1600)	6.2 (90)	7.6 (110)
12	136 (1200)	4.8 (70)	5.5 (80)

* Maximum dry service brake torque is 4000 lb-in. The 5200 lb-in, and 6000 lb-in torque is used only for coding of 3500 lb-in & 4000 lb-in oil-cooled brakes.

Other torques and/or release pressures are available upon request.

ASSIGNED NUMBERS

CATALOG CODE	MODEL NUMBER
3PB-130612-M	13-592-044
3PB-130619-MZ	13-592-046
3PB-130635-M	13-592-002
3PB-130640-M	13-592-004
3PB-130640-MZ	13-592-024
3PB-131328-B	13-592-036

CATALOG CODE	MODEL NUMBER
3PB-131335-B	13-592-010
3PB-131340-B	13-592-042
3PB-131340-MZ	13-592-022
3PB-131352-BZ	13-592-048
3PB-151552-BZ	13-592-050

Input Faces

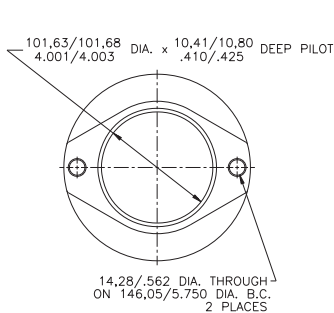

B - SAE B-Mount

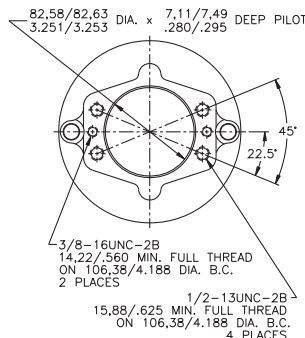

M - 4-Bolt and SAE A-Mount 2-Bolt



C-Mount Pressure Override Brakes, Modular Design



FEATURES

- Secondary system for service braking with fail-safe backup
- Standard SAE mounting flanges
- Service brake can be modulated with automotive type master cylinder or hydraulic valve
- Oil cooled option for added capacity
- Nitrile case seals
- Compact modular design

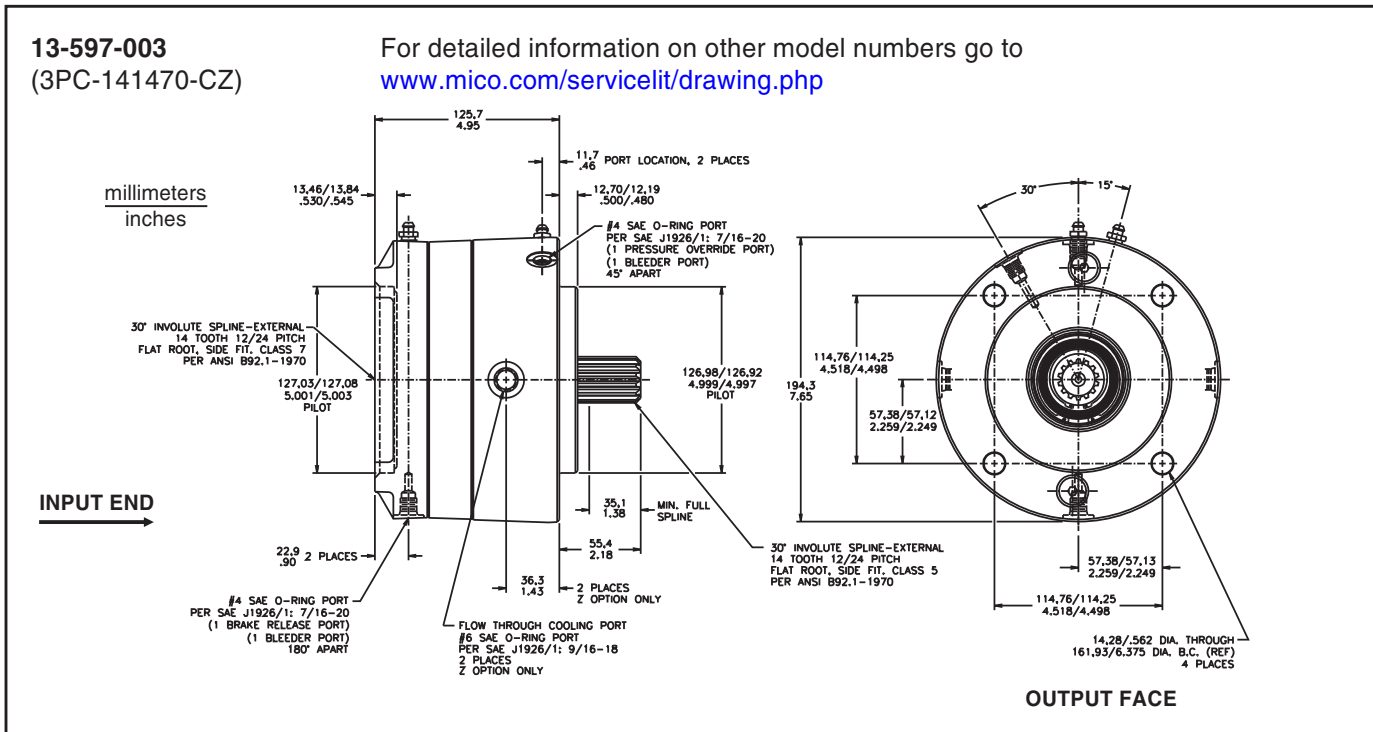

SPECIFICATIONS

FAIL-SAFE BRAKE

Torque range at 0 bar (0 PSI)
 back pressure 407 - 1469 N-m (3600 - 13,000 lb-in)
 Release pressure range 9.7 - 25.5 bar (140 - 370 PSI)
 Maximum continuous pressure 206.8 bar (3000 PSI)
 Maximum speed 4000 RPM
 (See note below)

Volume of oil
 to release brake 16.4 cm³ (1.0 in³)
 Fluid type Mineral base hydraulic oil
 Maximum operating temperature 132 °C (270 °F)
 Approximate weight 20 kg (44 lb)
 Optimal flow through cooling
 (wet design) 3.8 - 26.5 L/min (1 - 7 GPM)
 Maximum case pressure 2.1 bar (30 PSI)
 Sump cooling fluid volume (wet design)
 (horizontal) 118.3 mL (4 fl oz)
 (vertical) Contact MICO

SERVICE BRAKE

Maximum torque (dry design) 1062 N-m (9400 lb-in)
 (wet design) 700.6 N-m (6200 lb-in)
 Calculated torque (dry design) T = 10.10 x (PSI - 70)
 (wet design) T = 6.66 x (PSI - 70)
 Maximum operating pressure 69.0 bar (1000 PSI)
 Maximum energy input
 (wet or dry design). 406,800 joule (300,000 ft-lb)
 (one stop, no damage)
 Maximum energy input rate
 (dry design) 101,700 joule/s (75,000 ft-lb/s)
 (one stop, no damage)
 (wet design) 203,400 joule/s (150,000 ft-lb/s)
 (one stop, no damage)
 Piston volume 5.2 cm³ (0.32 in³)
 Fluid type Mineral base hydraulic oil

NOTE: Due to energy capacity limitations, maximum speed at time of service apply is dependent on product application.

CATALOG CODE (See NOTE on the top of page 6)

Not all of the brake combinations are possible due to certain design limitations.

NOTE: On oil-cooled models (Z option) actual torque is 67% of value shown on torque code chart.



**3P - PRESSURE
OVERRIDE**

OUTPUT FACE

C - SAE C-Mount
4-Bolt

OUTPUT SPLINE / INPUT SPLINE

	SAE Designation
14/00	00 = used with "R" only
14/06	06 = 25.4 mm (1.00 in) Diameter 6B
14/13	13 = 13T 8/16
14/14	14 = 14T 12/24
23/23	23 = 23T 16/32

For other configurations, consult a MICO Applications Specialist.

OPTION

(Available separately or in combination)
S - Speed Sensor
Z - Oil Cooled - see note above

INPUT FACE

C - SAE C-Mount Standard
C2 - SAE C-Mount 2-Bolt
C24 - 2-Bolt and 4-Bolt C-Mount
D - SAE D-Mount
K4 - Eaton Standard 4000
M - 4-Bolt and SAE A-Mount 2-Bolt
R - Closed Face

See Page 48 for Input Face Dimensions

NOTE: MICO recommends that all applications for pressure override brakes have a completed Data Sheet submitted to the MICO Application Department. Complete the online Application Data Sheet (80-500-010) at www.mico.com/datasheets/DataSheetCover.pdf.

TORQUE

Code	Torque Rating		Initial Release Pressure		Full Release Pressure	
	N-m	(lb-in)	bar	(PSI)	bar	(PSI)
98	1107	(9800)	18.6	(270)	25.5	(370)
80	904	(8000)	15.2	(220)	20.7	(300)
70	791	(7000)	13.8	(200)	19.3	(280)
57	644	(5700)	12.4	(180)	19.3	(280)
55	622	(5500)	11.0	(160)	15.2	(220)
45	508	(4500)	8.3	(120)	11.7	(170)
36	407	(3600)	6.9	(100)	9.6	(140)
13	1469	(13,000)	24.1	(350)	32.8	(475)

Other torques and/or release pressures are available upon request.

ASSIGNED NUMBERS

CATALOG CODE	MODEL NUMBER
3PC-140080-R	13-597-032
3PC-140645-M	13-597-034
3PC-140670-MZ	13-597-044
3PC-140680-M	13-597-026
3PC-141313-DZ	13-597-052
3PC-141398-DZ	13-597-046
3PC-141436-C	13-597-014
3PC-141436-C24	13-597-042
3PC-141436-M	13-597-040
3PC-141445-C24Z	13-597-030
3PC-141445-K4	13-597-072
3PC-141455-C	13-597-002
3PC-141455-CZ	13-597-016
3PC-141457-CZ	13-597-050
3PC-141470-C	13-597-004
3PC-141470-CZ	13-597-008
3PC-141470-C24Z	13-597-054
3PC-141480-C	13-597-018
3PC-141480-CZ	13-597-024
3PC-141498-C	13-597-010
3PC-141498-CZ	13-597-022
3PC-141498-C24Z	13-597-056
3PC-232380-CZ	13-597-070



Large Wheel Mount Brakes, Motor Input

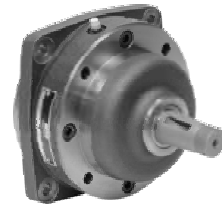

FEATURES

- Provision for direct mounting of brake to wheels
- Heat-treated 8620 shafts
- Complete self-contained, dry-design package
- Full system pressure capability

13-587-001
(WH-501415-M)

For detailed information on other model numbers go to
www.mico.com/servicelit/drawing.php

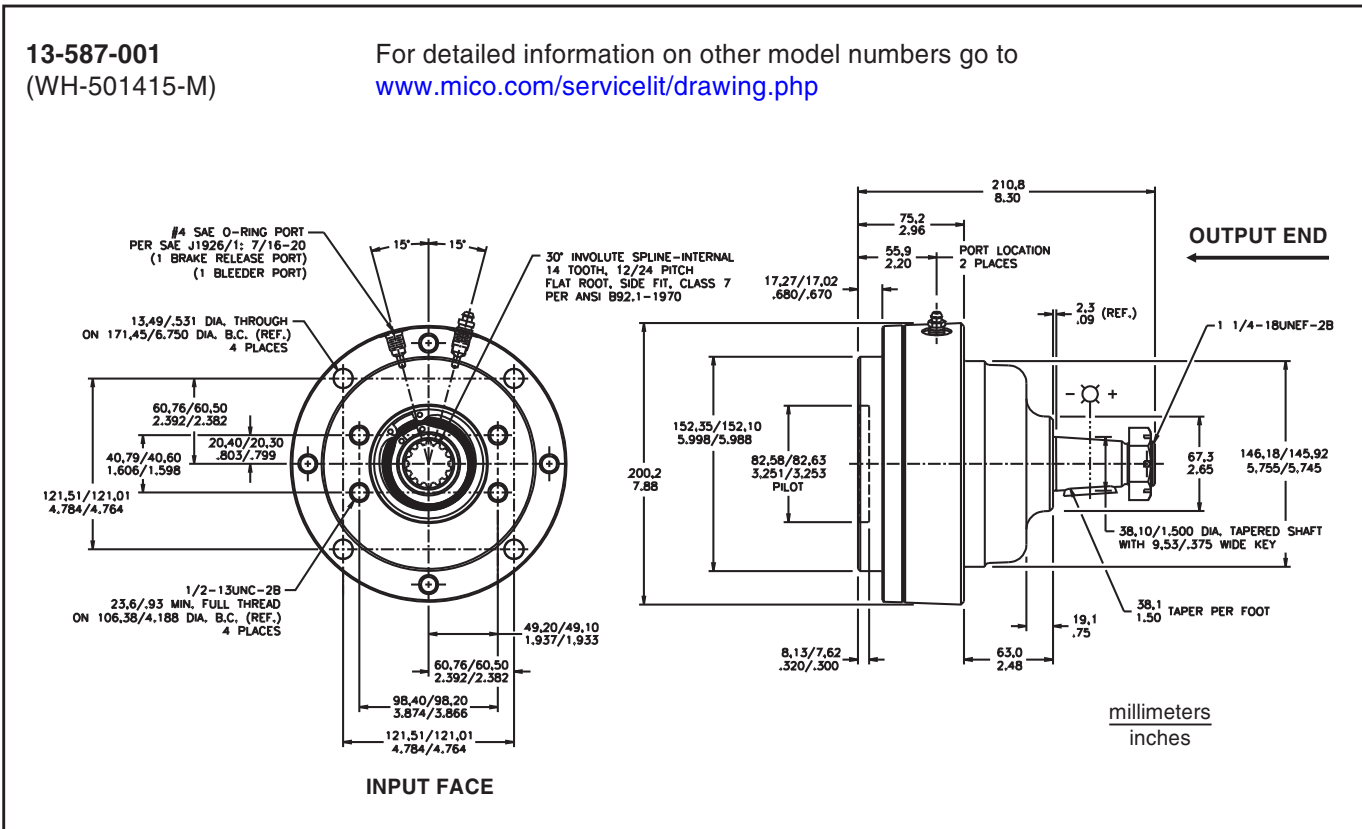

SPECIFICATIONS

Torque range at 0 bar (0 PSI)
back pressure. 904 - 1695 N-m (8000 - 15,000 lb-in)
Release pressure range 21.4 - 34.5 bar (310 - 500 PSI)
Maximum operating pressure 206.8 bar (3000 PSI)
Maximum speed 1000 RPM
Volume of oil
to release brake 9.8 cm³ (0.6 in³)

Maximum energy input 339,000 joule (250,000 ft-lb)
(one stop, no damage)
Fluid type Mineral base hydraulic oil
Maximum operating temperature 132 °C (270 °F)
Approximate weight 17.2 kg (38 lb)

CATALOG CODE (See NOTE on the top of page 6)

Not all of the brake combinations are possible due to certain design limitations.

NOTE: Dry design only, not for oil-cooled applications.



WH - WHEEL MOUNT BRAKE

OUTPUT SHAFT / INPUT SHAFT

	SAE Designation
50/06	06 = 25.4 mm (1.00 in) Diameter 6B
50/12	12 = 12T 12/24 modified (as required for Eaton 2000 Bearingless)
50/14	14 = 14T 12/24
	50 = 38.1 mm (1.50 in) Keyed, Taper

For other configurations, consult a MICO Applications Specialist.

INPUT FACE

- M - 4-Bolt and SAE
- A-Mount 2-Bolt
- L2 - Eaton Bearingless 2000
- K4 - Eaton Standard 4000

See Page 48 for Input Face Dimensions

TORQUE

Code	Torque Rating		Initial Release Pressure		Full Release Pressure	
	N-m	(lb-in)	bar	(PSI)	bar	(PSI)
80	904	(8000)	14.5	(210)	21.4	(310)
15	1695	(15,000)	26.9	(390)	40.0	(580)
12	1356	(12,000)	24.8	(360)	31.0	(450)
10	1130	(10,000)	17.9	(260)	26.2	(380)

Other torques and/or release pressures are available upon request.

ASSIGNED NUMBERS

CATALOG CODE	MODEL NUMBER
WH-500680-M	13-587-014
WH-501215-L2	13-587-004
WH-501280-L2	13-587-006
WH-501412-M	13-587-030
WH-501415-M	13-587-002
WH-501415-K4	13-587-008
WH-501480-M	13-587-012

**LOAD CAPACITY @ 100 RPM AND B₁₀ = 6500 HRS
325 RPM AND B₁₀ = 2000 HRS**

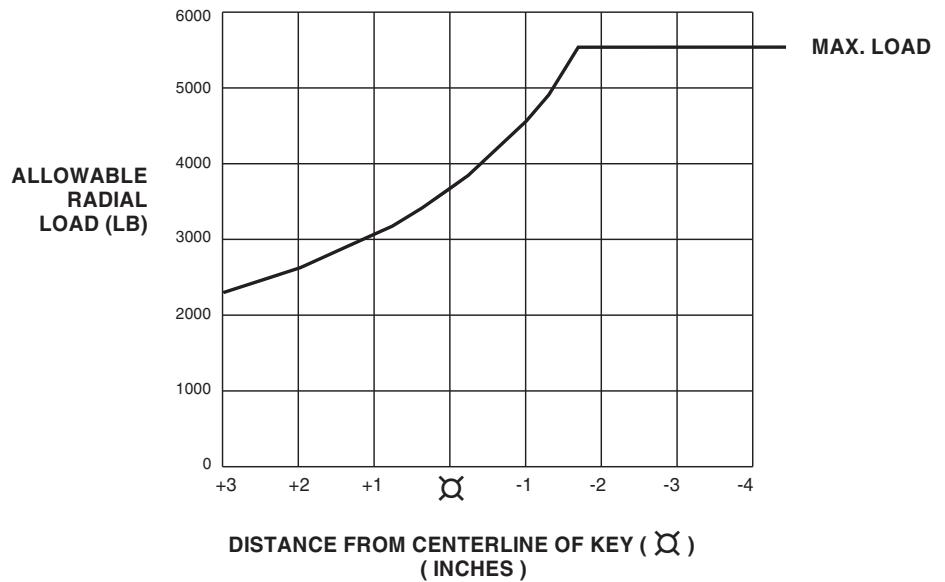

THRUST LOAD CAPACITY:

1100 lb max. @ 100 RPM & 2000 hrs B₁₀ life.
(Based on constant 3700 lb side load at centerline of key)



Large Wheel Mount Brakes, Closed Input

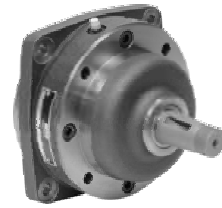

FEATURES

- Automotive type linings
- Provides direct mounting of brake to wheel
- Heat-treated 8620 shafts
- Low release pressures - ideal for use with closed-loop hydrostatic systems
- Full system pressure capability

13-587-020
(SWH-50096-R)

For detailed information on other model numbers go to
www.mico.com/servicelit/drawing.php

OUTPUT END
→

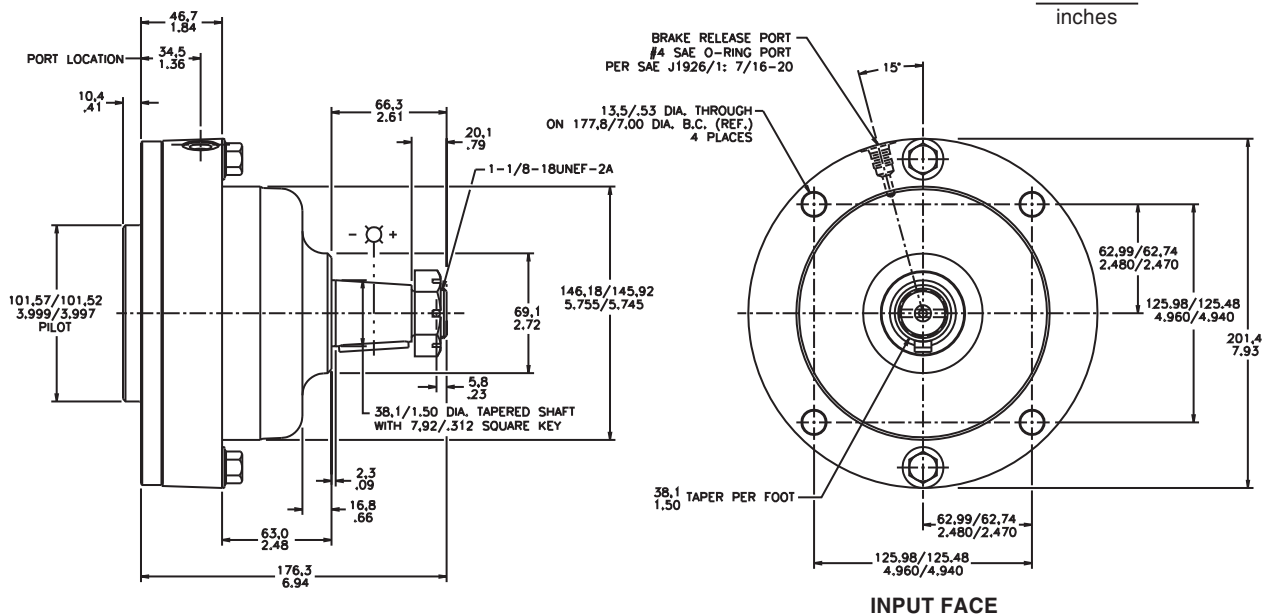

SPECIFICATIONS

Torque range at 0 bar (0 PSI)
back pressure 904 - 1356 N·m (5400 - 14,000 lb-in)
Release pressure range 21.37 - 34.5 bar (310 - 500 PSI)
Maximum operating pressure 206.8 bar (3000 PSI)
241.3 bar (3500 PSI) intermittent
Maximum speed 1000 RPM

Maximum energy input 335,000 joule (247,096 ft·lb)
Volume of oil to release brake 9.8 cm³ (0.6 in³)
Fluid type Mineral base hydraulic oil
Maximum operating temperature 132 °C (270 °F)
Approximate weight 17.2 kg (38 lb)

CATALOG CODE (See NOTE on the top of page 6)

Not all of the brake combinations are possible due to certain design limitations.



SWH - WHEEL MOUNT BRAKE

INPUT FACE
R - Closed Face

OUTPUT SHAFT

TORQUE

50 SAE Designation
50 = 38.1 mm (1.50 in) Keyed, Taper

Code	Torque Rating N-m (lb-in)	Initial Release Pressure bar (PSI)	Full Release Pressure bar (PSI)
96	1085 (9600)	26.2 (380)	31.7 (460)
54	6102 (5400)	24.1 (350)	27.6 (400)
14	1582 (14,000)	40.0 (580)	45.5 (660)

CLOSED INPUT

For other configurations, consult a MICO Applications Specialist.

Other torques and/or release pressures are available upon request.

**LOAD CAPACITY @ 100 RPM AND B₁₀ = 6500 HRS
325 RPM AND B₁₀ = 2000 HRS**

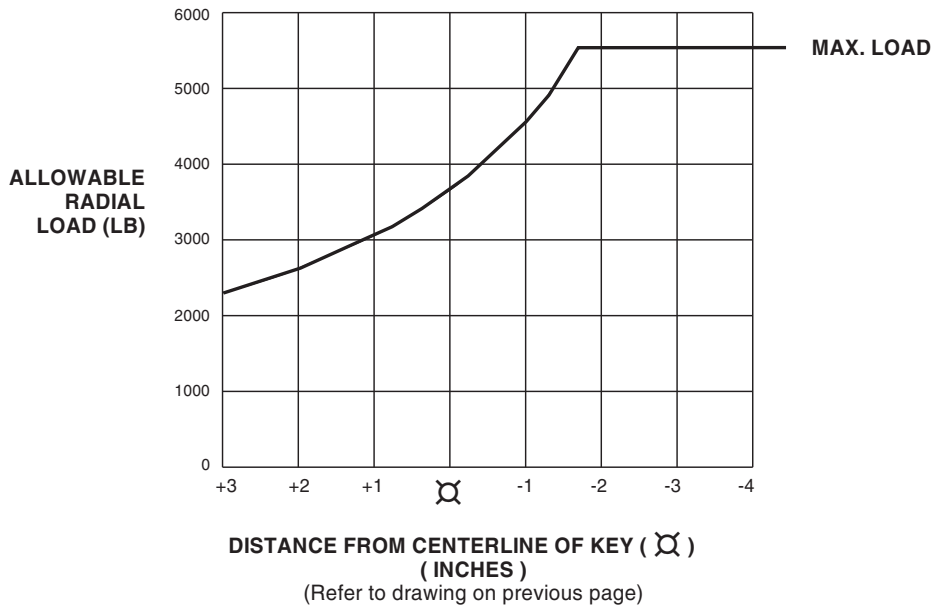

ASSIGNED NUMBERS

CATALOG CODE	MODEL NUMBER
SWH-500014-R	13-587-016
SWH-500054-R	13-587-024
SWH-500096-R	13-587-020

THRUST LOAD CAPACITY:
1100 lb max. @ 100 RPM & 2000 hrs B₁₀ life.
(Based on constant 3700 lb side-load at centerline of key)



Compact Wheel Mount Brakes, Motor Input



FEATURES

- Provides direct mounting of brake to wheel
- Wet design with patented pressure override option
- Metallic linings
- Designed for standard SAE hydraulic motor inputs

13-587-086
(MW-250642-AP)

For detailed information on other model numbers go to
www.mico.com/servicelit/drawing.php

millimeters
inches

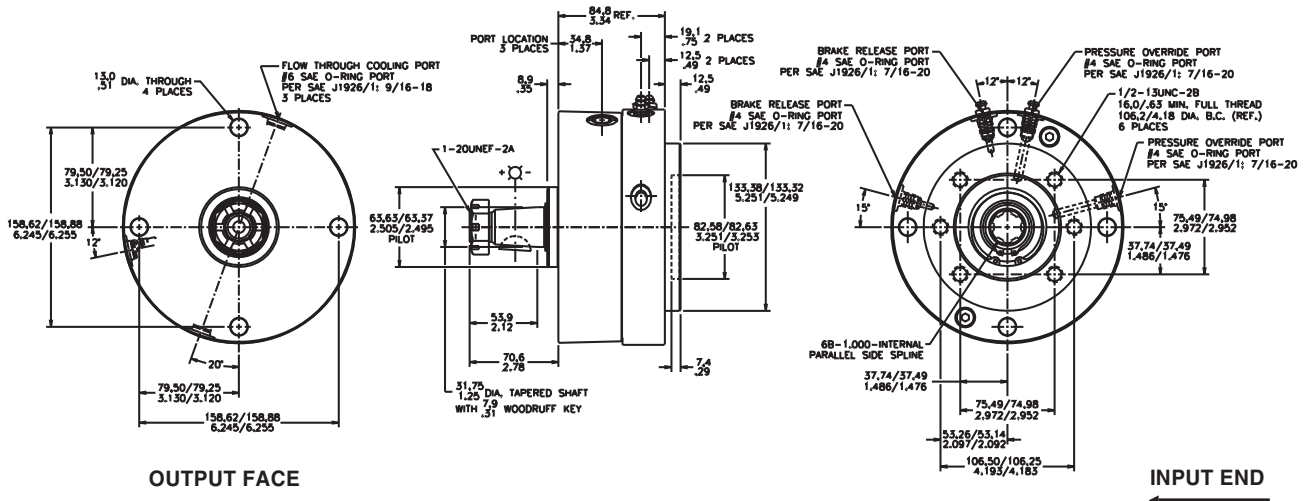

SPECIFICATIONS

Type Wet multiple disc brake, spring apply, hydraulic release with hydraulic apply service brake option

Release pressure 26.9 bar (390 PSI) initial, 31.7 bar (460 PSI) full 206.8 bar (3000 PSI) maximum (continuous)

Torque rating
parking/emergency 475 N-m (4200 lb-in) static @ 0 bar (0 PSI)

service brake 396 N-m (3500 lb-in) dynamic @ 103.4 bar (1500 PSI) maximum input pressure

Maximum speed 300 RPM

Maximum energy input 418,000 joule (308,300 ft-lb)

Lining material Metallic graphitic

Approximate weight 12 kg (27 lbs)

Sump cooling fluid volume 118.3 mL (4 fl. oz.)

Fluid type Mineral base hydraulic oil

CATALOG CODE (See NOTE on the top of page 6)

Not all of the brake combinations are possible due to certain design limitations.

NOTE: Wet design only, not intended for dry applications. To be installed in horizontal position only.



MW - MINI WHEEL BRAKE

OUTPUT SHAFT / INPUT SHAFT

50/06	SAE Designation
25/06	50 = 38.1 mm (1.50 in) Keyed, Taper
	25 = 31.8 mm (1.25 in) Keyed, Taper
	06 = 25.4 mm (1.00 in) Diameter 6B

For other configurations, consult a MICO Applications Specialist.

OPTIONS

P - Pressure Override

INPUT FACE

A - SAE A-Mount 2-Bolt

TORQUE

Code	Torque Rating		Initial Release Pressure		Full Release Pressure	
	N·m	(lb·in)	bar	(PSI)	bar	(PSI)
42	475	(4200)	26.9	(390)	31.7	(460)

NOTE: Torque is coded as wet use.

Other torques and/or release pressures are available upon request.

NOTE: MICO recommends that all applications for pressure override brakes have a completed Data Sheet submitted to the MICO Application Department. Complete the online Application Data Sheet (80-500-010) at www.mico.com/datasheets/DataSheetCover.pdf.

LOAD CAPACITY @ 240 RPM AND B₁₀ = 3000 HRS

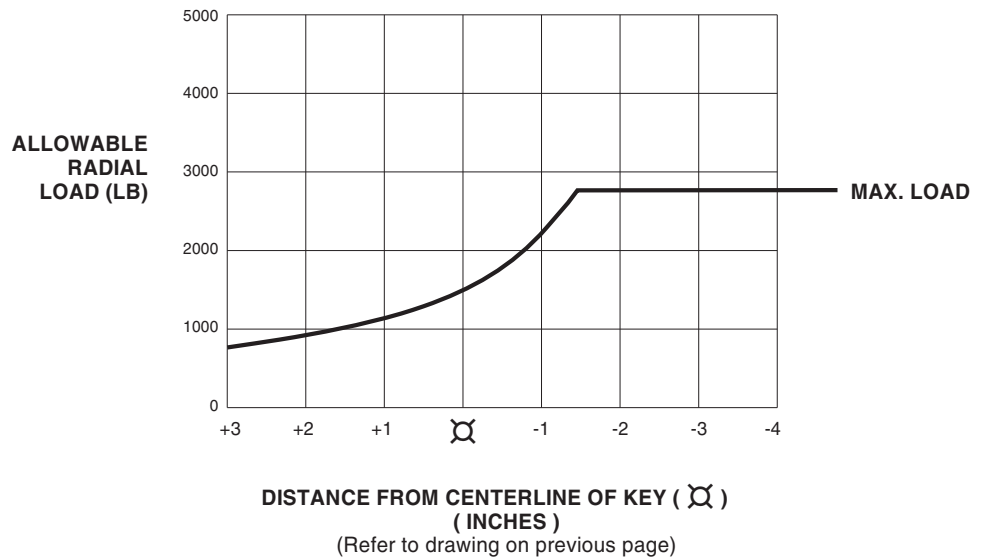

ASSIGNED NUMBERS

CATALOG CODE	MODEL NUMBER
MW-250642-AP	13-587-086



Compact Wheel Mount Brakes, Closed Input



FEATURES

- Non-metallic type linings
- Provides direct mounting of brake to wheel
- Low release pressures - ideal for use with closed-loop hydrostatic systems
- Full system pressure capability
- Integral hub eliminates the need for an adaptor
- Superior radial wheel load capacities

13-587-072
(MW-054560-R)

For detailed information on other model numbers go to
www.mico.com/servicelit/drawing.php

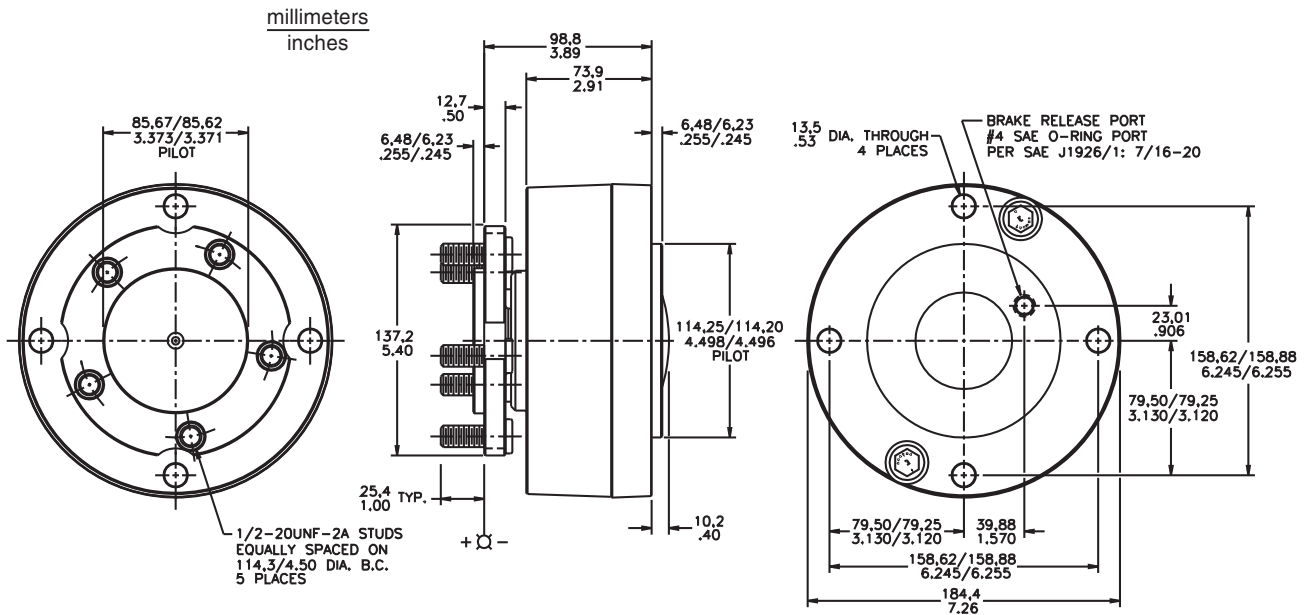

SPECIFICATIONS

Torque range at 0 bar (0 PSI)
back pressure 170 - 1130 N·m (1500 to 10,000 lb-in)
Release pressure range 6.9 - 27.6 bar (100 - 400 PSI)
Maximum sustained operating pressure 206.8 bar (3000 PSI)
275.8 bar (4000 PSI) intermittent
Maximum speed 100 RPM or 200 RPM depending on model
Maximum operating temperature 93 °C (200 °F)
Maximum energy input 231,000 joule (170,500 ft-lb)

Approximate weight 10.4 kg (23 lb)
Volume of oil to release brakes 8.2 cm³ (0.5 in³) minimum
14.8 cm³ (0.9 in³) maximum
Fluid type Mineral base hydraulic oil

CATALOG CODE (See NOTE on the top of page 6)

Not all of the brake combinations are possible due to certain design limitations.

NOTE: On oil-cooled models (Z option) actual torque is 67% of value shown on torque code chart.



MW - MINI WHEEL BRAKE

OPTIONS

Z - Oil Cooled - see note above

WHEEL MOUNT CONFIGURATION

0440 = 4-Bolt on 4.00 inch B.C.
 0445 = 4-Bolt on 4.50 inch B.C.
 0545 = 5-Bolt on 4.50 inch B.C.
 2500 = 31.8 mm (1.25 in) Keyed, Taper
 5000 = 38.1 mm (1.50 in) Keyed, Taper

INPUT FACE

R - Closed Face

TORQUE

For other configurations, consult a MICO Applications Specialist.

Code	Torque Rating		Initial Release Pressure		Full Release Pressure	
	N-m	(lb-in)	bar	(PSI)	bar	(PSI)
90	1017	(9000)	24.1	(385)	29.0	(460)
60	678	(6000)	33.8	(490)	40.0	(580)
51	576	(5100)	25.2	(385)	29.6	(460)
40	452	(4000)	21.0	(335)	24.0	(385)
35	396	(3500)	18.6	(300)	21.0	(340)
25	283	(2500)	16.6	(240)	19.3	(280)
10	1130	(10,000)	25.2	(400)	29.6	(470)

Other torques and/or release pressures are available upon request.

**LOAD CAPACITY @ 100 RPM AND B₁₀ = 6500 HRS
 325 RPM AND B₁₀ = 2000 HRS**

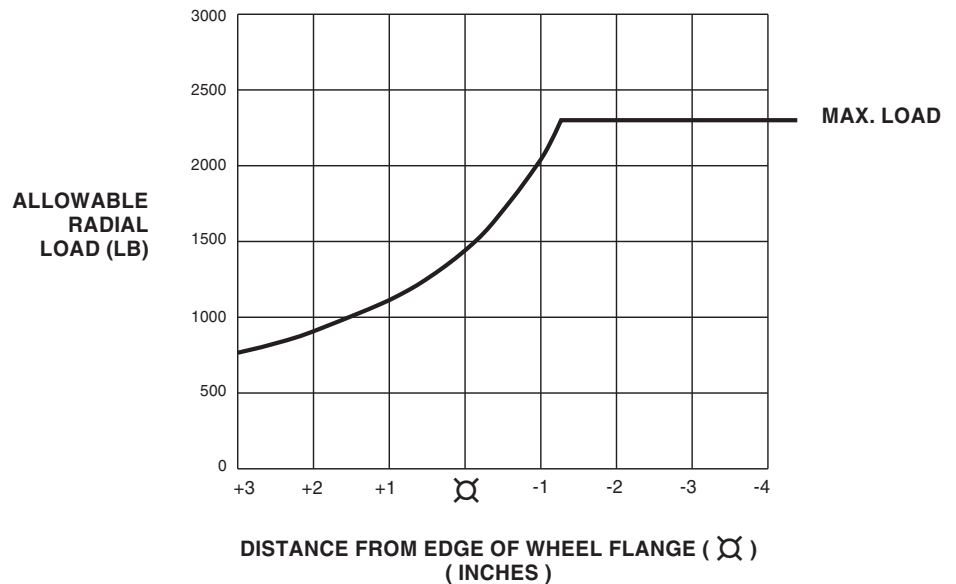

(Refer to drawing on previous page)

ASSIGNED NUMBERS

CATALOG CODE	MODEL NUMBER
MW-054525-RZ	13-587-068
MW-054535-R	13-587-074
MW-054560-R	13-587-072
MW-054590-R	13-587-082
MW-500051-R	13-587-080

THRUST LOAD CAPACITY:

300 lb max. @ 100 RPM & 2000 hrs B₁₀ life.
 (Based on constant 290 lb side-load at edge of wheel flange)



Driveline Multiple Disc Brakes



FEATURES

- Enclosed/sealed wet design
- Tapered roller bearings for high radial and thrust loads
- Metallic linings provide high energy and long life
- Isolation from environmental contaminants
- Developed to retrofit competitive drum/caliper driveline parking brakes
- Lining wear indicator port

02-560-104
(DB-757518)

For detailed information on other model numbers go to
www.mico.com/servicelit/drawing.php

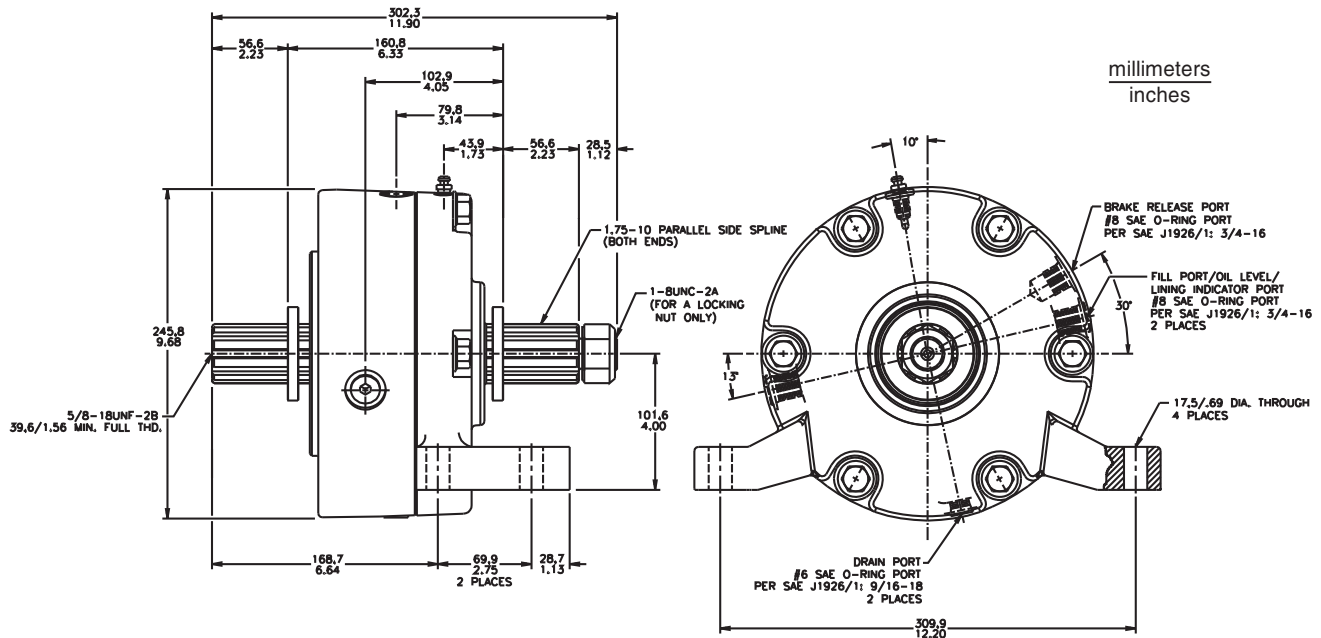

SPECIFICATIONS

Type Wet multiple disc brake, spring apply, hydraulic release

Release pressure for 2034 N·m (18,000 lb-in) version 18.6 bar (270 PSI) initial
22.4 bar (325 PSI) full
137.9 bar (2000 PSI) maximum (continuous)

Release pressure for 2825 N·m (25,000 lb-in) version 24.1 bar (350 PSI) initial
29.0 bar (420 PSI) full
137.9 bar (2000 PSI) maximum (continuous)

Torque Rating 2034 N·m (18,000 lb-in) static (breakaway)
2825 N·m (25,000 lb-in) static (breakaway)

Volume of oil required to release brake 32.8 cm³ (2 in³)

Sump cooling fluid volume 236.6 mL (8 fl. oz.)

Maximum speed 3200 RPM

Maximum energy input 1,654,000 joule (1,220,000 ft-lb)

Approximate weight 42 kg (92 lb)

Fluid type Mineral base hydraulic oil

CATALOG CODE (See NOTE on the top of page 6)

Not all of the brake combinations are possible due to certain design limitations.



DB - DRIVELINE BRAKE

OUTPUT SHAFT / INPUT SHAFT

75/75 - 1.75 inch Diameter 10B Parallel Spline-External
 50/50 - 1.50 inch Diameter 10B Parallel Spline-Internal
 (through-shaft)

For other configurations, consult a MICO Applications Specialist.

TORQUE

Code	Torque Rating		Initial Release Pressure		Full Release Pressure	
	N-m	(lb-in)	bar	(PSI)	bar	(PSI)
25	2825	(25,000)	24.1	(350)	29.0	(420)
18	2034	(18,000)	18.6	(270)	22.4	(325)

NOTE: Torque is coded as wet use.

Other torques and/or release pressures are available upon request.

ASSIGNED NUMBERS

CATALOG CODE	MODEL NUMBER
DB-505018	02-560-108
DB-505025	02-560-110
DB-757518	02-560-104
DB-757525	02-560-106

CATALOG CODE (See NOTE on the top of page 6)

Not all of the brake combinations are possible due to certain design limitations.



DBT - DRIVELINE BRAKE THROUGH MOUNT

OUTPUT SHAFT / INPUT SHAFT

75/75 - 1.75 inch Diameter 10B Parallel Spline-External

For other configurations, consult a MICO Applications Specialist.

TORQUE

Code	Torque Rating		Initial Release Pressure		Full Release Pressure	
	N-m	(lb-in)	bar	(PSI)	bar	(PSI)
25	2825	(25,000)	24.1	(350)	29.0	(420)

NOTE: Torque is coded as wet use.

Other torques and/or release pressures are available upon request.

ASSIGNED NUMBERS

CATALOG CODE	MODEL NUMBER
DBT-757525	02-560-118



Driveline Multiple Disc Brakes, Through Mount Compact



FEATURES

- Enclosed/sealed wet design
- Tapered roller bearings for high radial and thrust loads
- Metallic linings provide high energy and long life
- Isolation from environmental contaminants
- Developed to retrofit competitive drum/caliper driveline parking brakes
- Lining wear indicator port

02-560-116
(DB-141412)

For detailed information on other model numbers go to
www.mico.com/servicelit/drawing.php

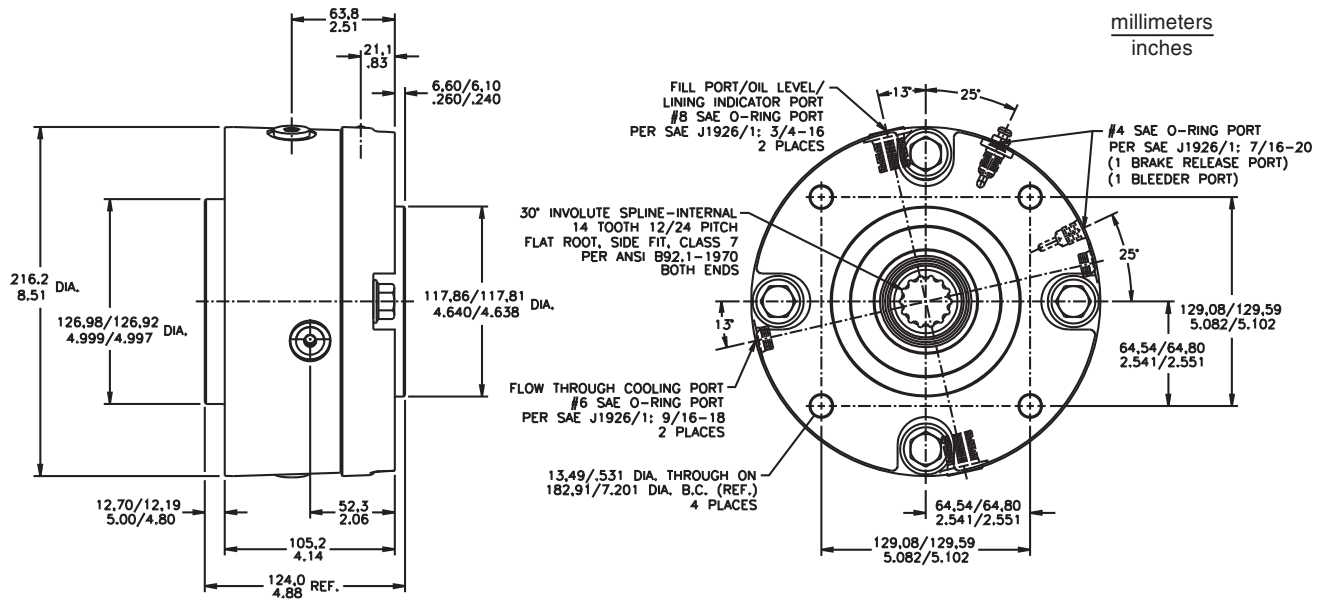

SPECIFICATIONS

Type Wet multiple disc brake, spring apply, hydraulic release

Release pressure 17.9 bar (260 PSI) initial
24.1 bar (350 PSI) full
137.9 bar (2000 PSI) maximum (continuous)

Torque Rating 1356 N-m (12,000 lb-in) static (breakaway)

Volume of oil required to release brake 32.8 cm³ (2 in³)

Sump cooling fluid volume 236.6 mL (8 fl. oz.)

Maximum speed 3200 RPM

Approximate weight 24 kg (53 lb)

Fluid type Mineral base hydraulic oil

CATALOG CODE (See NOTE on the top of page 6)

Not all of the brake combinations are possible due to certain design limitations.



DBTC - DRIVELINE BRAKE THROUGH MOUNT COMPACT

OUTPUT SHAFT / INPUT SHAFT

14/14
 75/75 - 14 = 14T 12/24 (interval)
 1.75 inch Diameter 10B Parallel Spline-External

For other configurations, consult a MICO

TORQUE

Code	Torque Rating	Initial Release Pressure	Full Release Pressure
	N-m (lb-in)	bar (PSI)	bar (PSI)
12	1356 (12,000)	17.9 (260)	24.1 (350)

NOTE: Torque is coded as wet use.

Other torques and/or release pressures are available upon request.

ASSIGNED NUMBERS

CATALOG CODE	MODEL NUMBER
DBT-141412	02-560-116



Input Face Dimensional Information

Reference for Page 13

millimeters
inches

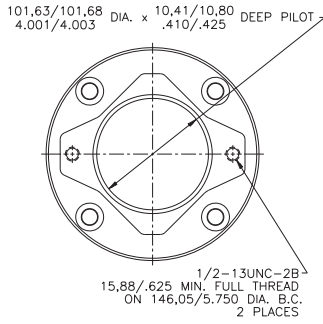

B - SAE B-Mount 2-Bolt

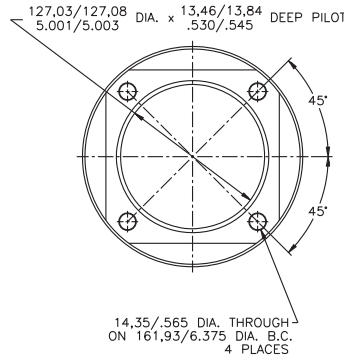

C - SAE C-Mount 4-Bolt

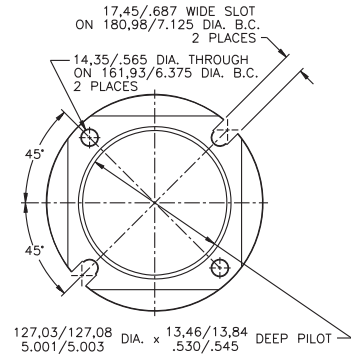

C2 - SAE C-Mount 2-Bolt Through

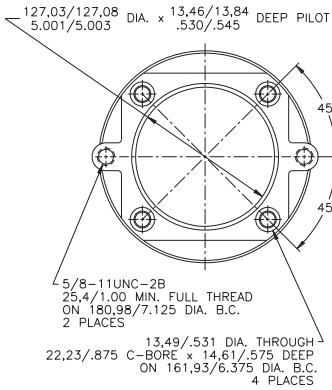

C24 - 2-Bolt and 4-Bolt C-Mount

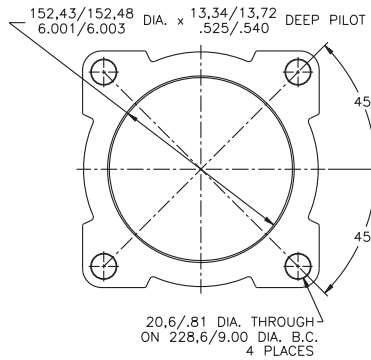

D - SAE D-Mount

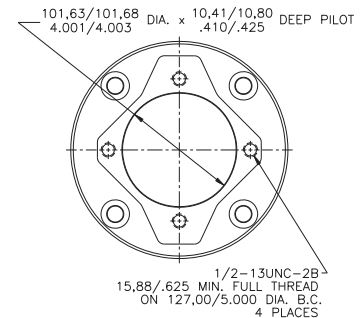

K4 - Eaton Standard 4000

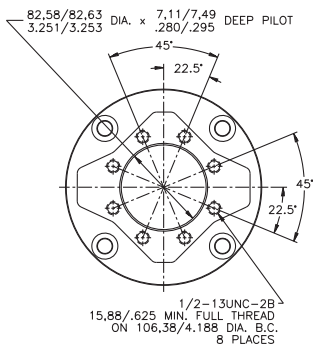

M - 4-Bolt and SAE A-Mount 2-Bolt

Reference for Page 19

millimeters
inches

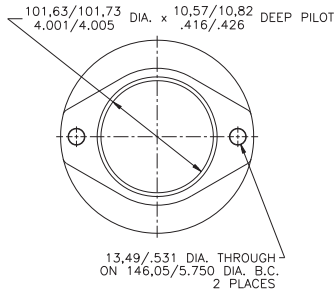

B - SAE B-Mount 2-Bolt

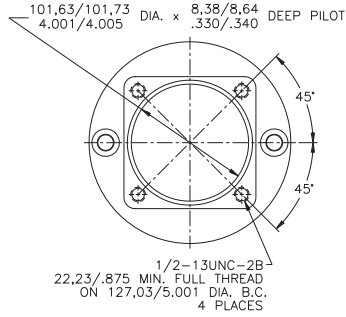

L2 - Eaton Bearingless 2000

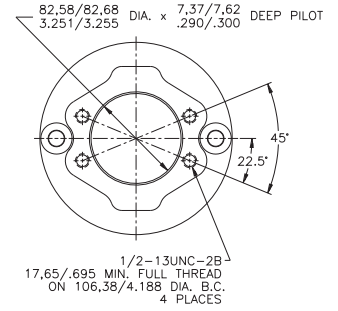

M - Modified SAE A-Mount 2-Bolt

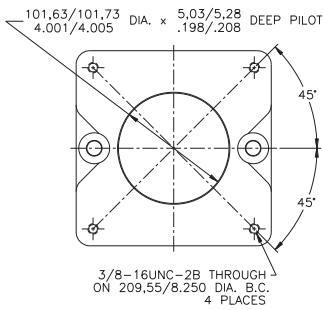

NEMA Mount

Reference for Page 27

millimeters
inches

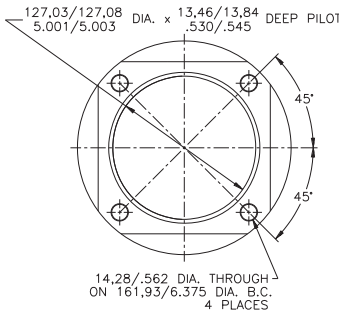

C - SAE C-Mount Standard

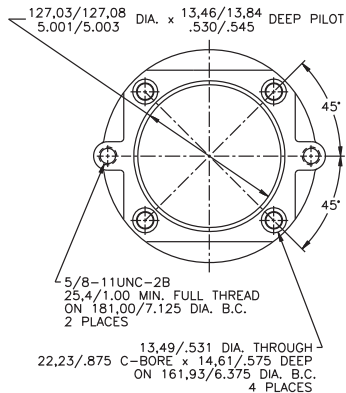

C24 - 2-Bolt and 4-Bolt C-Mount

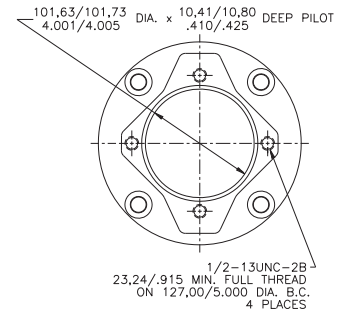

K4 - Eaton Standard 4000

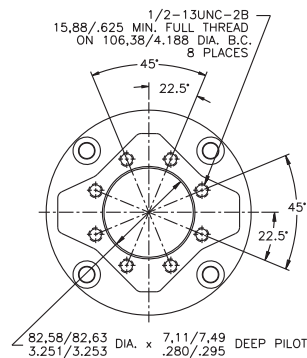

M - 4-Bolt and SAE A-Mount 2-Bolt



Input Face Dimensional Information

Reference for Page 31

millimeters
inches

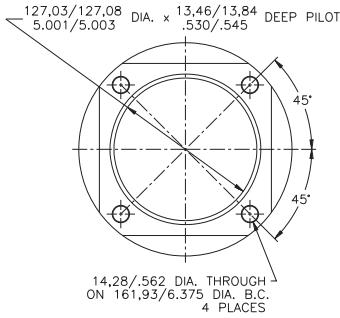

C - SAE C-Mount Standard

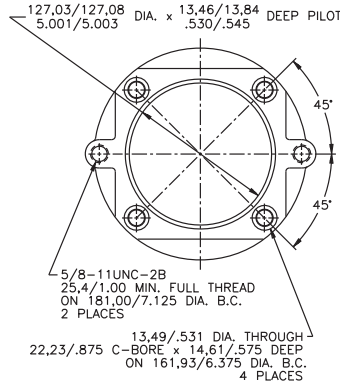

C24 - 2-Bolt and 4-Bolt C-Mount

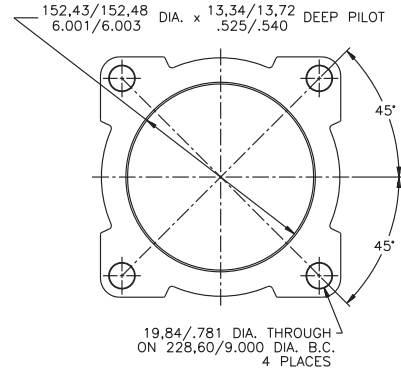

D - SAE D-Mount

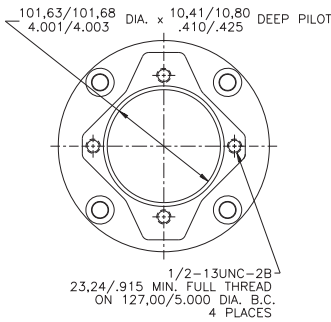

K4 - Eaton Standard 4000

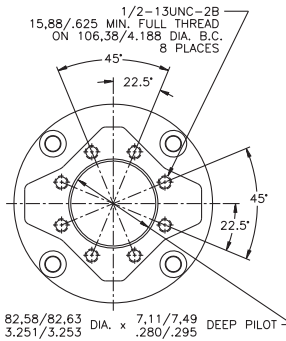

M - 4-Bolt and SAE A-Mount 2-Bolt

Reference for Page 33

millimeters
inches

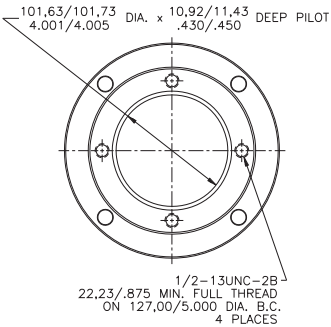

K4 - Eaton Standard 4000

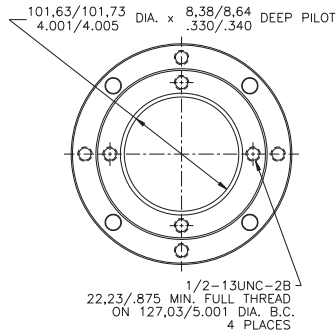

L2 - Eaton Bearingless 2000

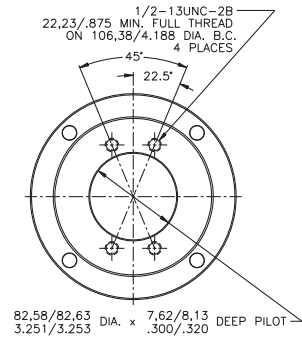

M - 4-Bolt and SAE A-Mount 2-Bolt

MICO has made every attempt to present accurate information in catalogs, brochures, and other printed material. MICO can accept no responsibility for errors from unintentional oversights that may exist. Due to a continuous program of product improvement, both materials and specifications are subject to change without notice or obligation. Refer to www.mico.com for the most recent versions of our literature. If you have any further questions, please call MICO.



Innovative Braking and Controls Worldwide

MICO, Incorporated

1911 Lee Boulevard
North Mankato, MN U.S.A. 56003-2507
Tel: +1 507 625 6426 Fax: +1 507 625 3212

MICO Europe Ltd.

Goodwood Road / Pershore
Worcestershire Wr10 2RY England
Tel: +44(0)1386 555562 Fax: +44(0)1386 553955

Web Site: www.mico.com

MICO is a registered trademark of MICO, Inc. MICO is registered in the U.S. Patent and Trademark Office as well as in Australia, Indonesia, Japan, Peoples Republic of China, South Korea, and the European Community.

PRODUCT LINE:

Brakes

Caliper Disc Brakes
Multiple Disc Brakes

Brake Locks

Electric
Mechanical

Controls

Electronic Controls
Hydraulic Throttle Controls
Pedal Controls
Switches
Transducers/Sensors

Cylinders

Drive Axle Brake Actuators
Slave Cylinders
Wheel Cylinders

Master Cylinders

Boosted Cylinders
Hydraulically and Air Actuated
Straight Bore Cylinders
Two-Stage Cylinders

Valves

Accumulator Charging
Electrohydraulic Brake
Park Brake
Pressure Modulating

Miscellaneous Components

In-line Residual Check Valves
Pump with Integrated Valves
Reservoirs