

NOTES:

1. TO BE USED WITH DOT 3, 4 OR 5 BRAKE FLUID ONLY.
2. DIMENSIONS MAY VARY BETWEEN UNITS AND ARE TO BE USED FOR REFERENCE PURPOSES ONLY. MILLIMETER VALUES MAY NOT BE AN EXACT CONVERSION OF INCH VALUES.
3. DRAWING IS SHOWN IN APPLIED POSITION.
4. 20-000-049 FITTING KIT INCLUDED.

PERFORMANCE CHARACTERISTICS:

1. PRESSURE SETTINGS:
 - CONTACTS OPEN BY 750 PSI MAX. INCREASING
 - CONTACTS CLOSE BY 550 PSI MIN. DECREASING.
2. WEATHER RESISTANT ADJUSTABLE PRESSURE SWITCH:
 - PROOF PRESSURE: 15,000 PSI.
 - LEAD WIRE LENGTH: 16" APPROXIMATE.
 - WIRE CODE: BLACK - COMMON
RED - NORMALLY CLOSED.
3. SWITCH SPECIFICATIONS:
 - SINGLE POLE DOUBLE THROW.
 - RATED: 12 VDC 30 VDC 125 VAC 250 VAC
3 AMPS INDUCTIVE 3 AMPS INDUCTIVE 5 AMPS 5 AMPS
5 AMPS RESISTIVE 5 AMPS RESISTIVE

CAUTION:
WHEN LOADS IN EXCESS OF ABOVE MAY BE ENCOUNTERED:
AUXILIARY RELAY MAY BE USED.
SUGGESTED RELAYS:
MOTORCRAFT D6T2 13853-A
GENERAL MOTORS 1-2480982

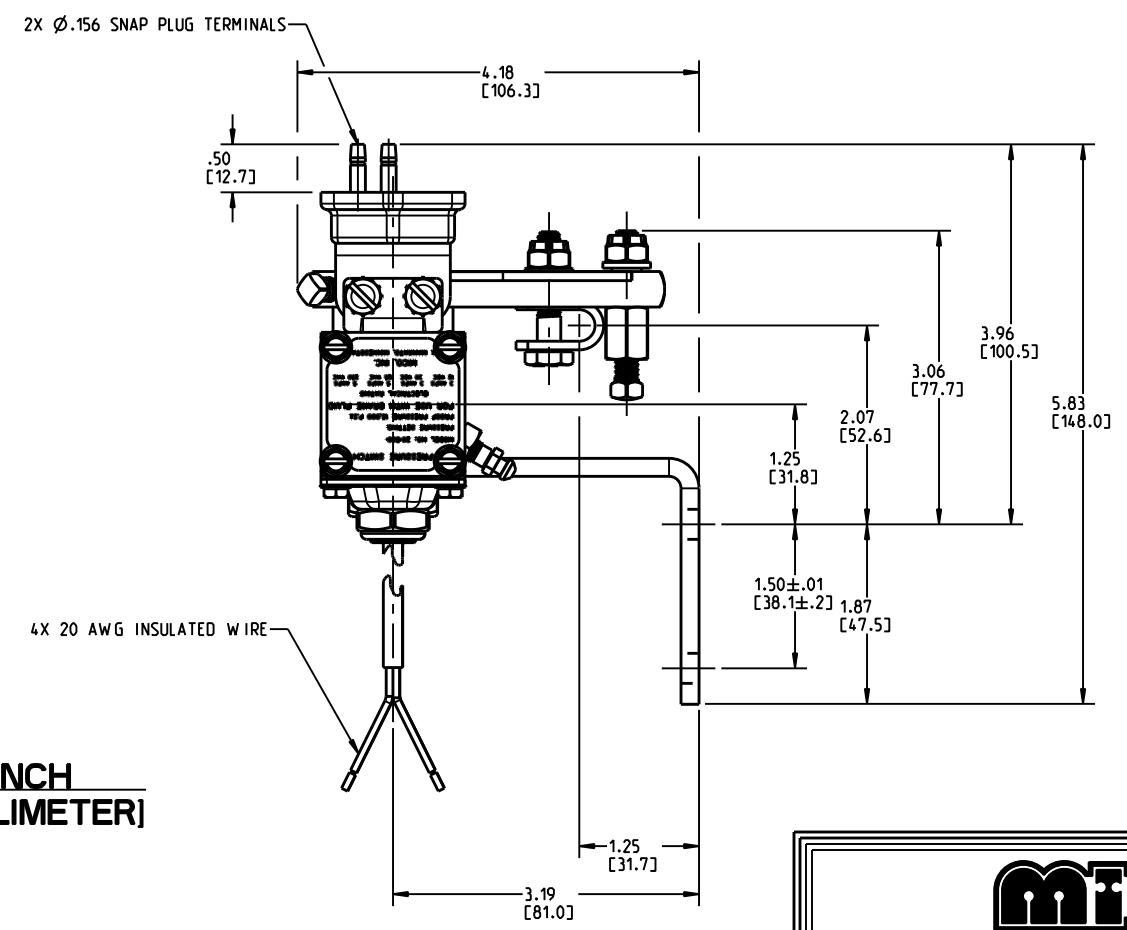
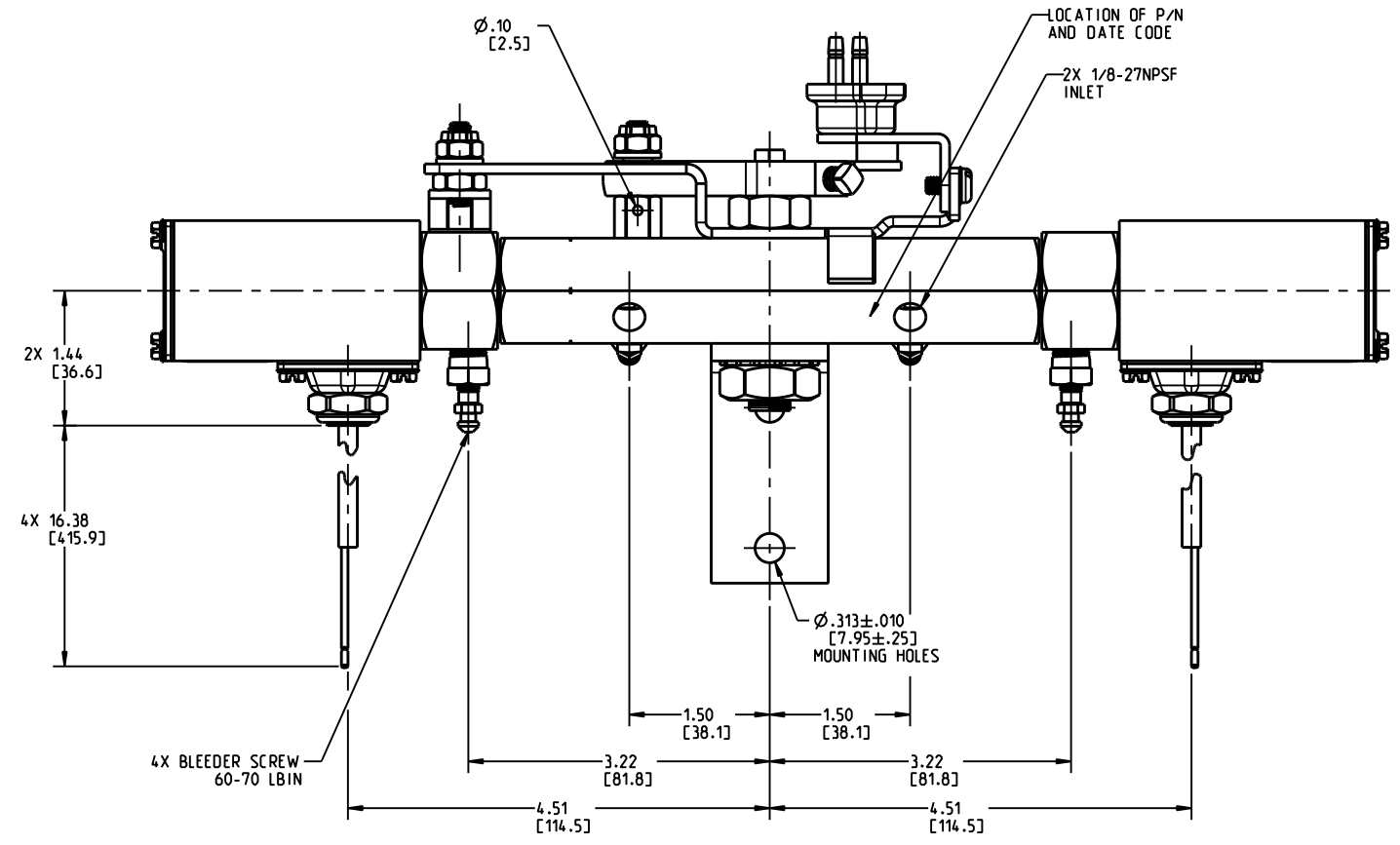

INCH
[MILLIMETER]



COMPONENT AND SYSTEM RECOMMENDATIONS MADE BY MICO, INC ARE BASED ON INFORMATION SUPPLIED BY POTENTIAL USER AND/OR SYSTEM DESIGNER. THE POTENTIAL USER AND/OR DESIGNER MUST MAKE FINAL ACCEPTANCE AND APPROVAL OF COMPONENTS AND SYSTEM AFTER TESTING PERFORMANCE ON AN ACTUAL APPLICATION FOR WHICH SYSTEM WAS DESIGNED.		MICO, INC CLAIMS PROPRIETARY RIGHTS TO THE MATERIAL DISCLOSED IN THIS DOCUMENT. THIS DOCUMENT IS PROVIDED IN CONFIDENCE AND MAY NOT BE REPRODUCED OR DISCLOSED WITHOUT WRITTEN PERMISSION FROM MICO, INC. COPYRIGHT MICO, INC. ALL RIGHTS RESERVED.	
SCALE 0.500	TITLE DUALOCK	SIZE B	REV N
DWN MAP 2009-06-01	APVD PROD ENGRG DPD 2009-09-04	DRAWING NUMBER 02-640-169	CUSTOMER COPY
X NO .	APVD ENGRG BSW 2009-09-03		