

DRAWING NUMBER
02-556-346
NPI OR ECN NO
ECN000289

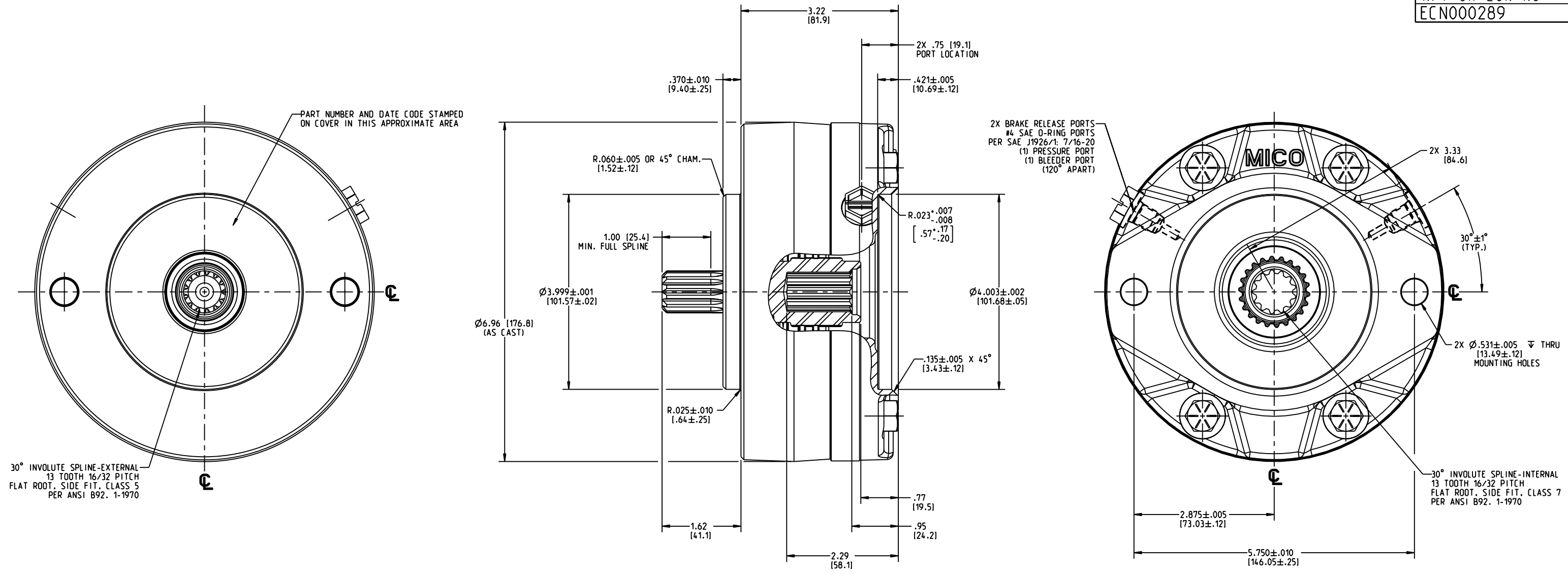

NOTES:

1. FOR USE WITH MINERAL BASE HYDRAULIC OIL ONLY
2. DIMENSIONS MAY VARY BETWEEN UNITS AND ARE FOR REFERENCE PURPOSES ONLY. MILLIMETER VALUES MAY NOT BE AN EXACT CONVERSION OF INCH VALUES
3. LINING REPAIR KIT P/N 20-060-105
4. BEARING REPAIR KIT P/N 02-500-142
5. O-RING REPAIR KIT P/N 02-500-141
6. SPRING REPAIR KIT P/N 12-501-515
7. BRAKE SURFACE COATING: BLUE GLOSSY POLYURETHANE PAINT.

SPECIFICATIONS:

TYPE:	DRY MULTIPLE DISC BRAKE, SPRING APPLY, HYDRAULIC RELEASE
MAXIMUM SPEED:	4,000 RPM SHAFT SPEED CAPABILITY SPECIFIED IS FOR BRAKE IN RELEASED CONDITION. ENERGY ABSORPTION DURING APPLY CYCLE MUST BE CAREFULLY EXAMINED FOR EACH APPLICATION.
TORQUE RATING:	1,200 LBIN STATIC (BREAKAWAY) ACTUAL TORQUE MAY VARY BY UP TO 10% DUE TO MANUFACTURING TOLERANCES.
RELEASE PRESSURE:	200 PSI INITIAL, 235 PSI FULL & 3,000 PSI MAX.
LINING MATERIAL:	SINTERED BRONZE
VOLUME OF OIL REQUIRED: TO RELEASE BRAKE	0.5 IN ³ MIN., 0.9 IN ³ MAX.
APPROXIMATE WEIGHT:	23 LB

**INCH
(MILLIMETER)**



COMPONENT AND SYSTEM RECOMMENDATIONS MADE BY MICO, INC ARE BASED ON INFORMATION SUPPLIED BY POTENTIAL USER AND/OR SYSTEM DESIGNER. THE POTENTIAL USER AND/OR DESIGNER MUST MAKE FINAL ACCEPTANCE AND APPROVAL OF COMPONENTS AND SYSTEM AFTER TESTING PERFORMANCE ON AN ACTUAL APPLICATION FOR WHICH SYSTEM WAS DESIGNED.		MICO, INC CLAIMS PROPRIETARY RIGHTS TO THE MATERIAL DISCLOSED IN THIS DOCUMENT. THIS DOCUMENT IS PROVIDED IN CONFIDENCE AND MAY NOT BE REPRODUCED OR DISCLOSED WITHOUT WRITTEN PERMISSION FROM MICO, INC. COPYRIGHT MICO, INC. ALL RIGHTS RESERVED.	
SCALE 0.500	TITLE SLMB-131312-BH MULTIPLE DISC BRAKE	SIZE B	DRAWING NUMBER 02-556-346
DWN RGBS1 2012-01-25	APVD PROD ENGRG PJS 2013-03-05	REV L	CUSTOMER COPY
X NO X4971-70	APVD ENGRG RV 12/05/12		