

DRAWING NUMBER
03-460-220
NPI OR ECN NO
ECN D000040

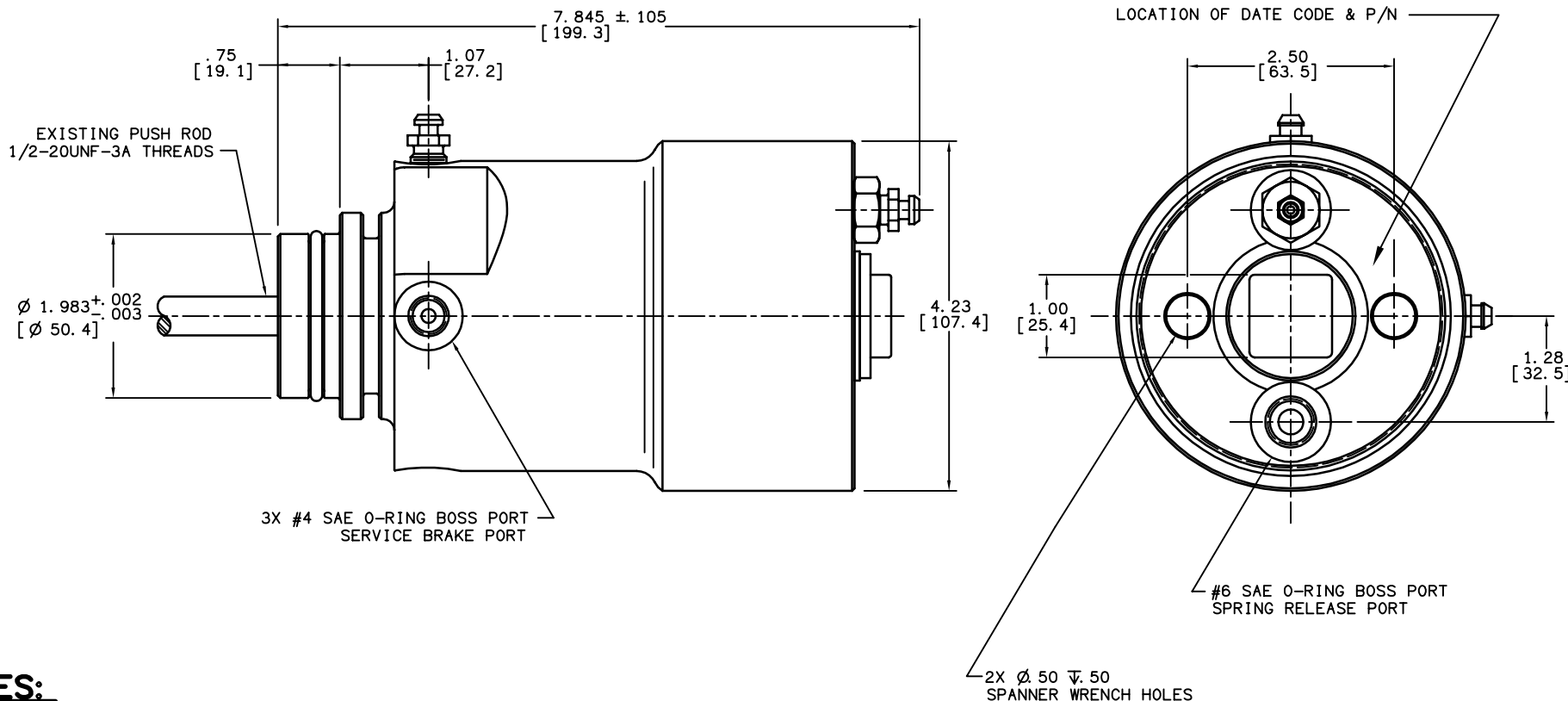

NOTES:

- 1) FOR USE WITH MINERAL BASE HYDRAULIC OIL ONLY.
- 2) DIMENSIONS MAY VARY SLIGHTLY BETWEEN UNITS AND ARE TO BE USED FOR REFERENCE PURPOSES ONLY.
- 3) ACTUATOR REPAIR KIT P/N 02-400-201.

PERFORMANCE CHARACTERISTICS:

SERVICE APPLY

EFFECTIVE AREA: .590 SQIN
STROKE: .50 IN.
VOLUME REQUIRED AT FULL STROKE: .295 CUIN
MAX. INLET PRESSURE: 3000 PSI

SPRING APPLY

LOAD WHEN PISTON IS RETRACTED: 1240 LBS.
PRESSURE REQUIRED TO RETRACT SPRING FULLY: 157 PSI
VOLUME REQUIRED TO RETRACT SPRING: 3.93 CUIN @ .500 TRAVEL.
MAX. SYSTEM PRESSURE: 3000 PSI

COMPONENT AND SYSTEM RECOMMENDATIONS MADE BY MICO, INC. ARE BASED ON INFORMATION SUPPLIED BY POTENTIAL USER AND/OR SYSTEM DESIGNER. THE POTENTIAL USER AND/OR DESIGNER MUST MAKE FINAL ACCEPTANCE AND APPROVAL OF COMPONENTS AND SYSTEM AFTER TESTING PERFORMANCE ON AN ACTUAL APPLICATION FOR WHICH SYSTEM WAS DESIGNED.

MICO, INC. CLAIMS PROPRIETARY RIGHTS TO THE MATERIAL DISCLOSED IN THIS DOCUMENT. THIS DOCUMENT IS PROVIDED IN CONFIDENCE AND MAY NOT BE REPRODUCED OR DISCLOSED WITHOUT WRITTEN PERMISSION FROM MICO, INC. COPYRIGHT MICO, INC. ALL RIGHTS RESERVED.

INCH
[MILLIMETER]



TITLE BRAKE ACTUATOR			
SCALE 1/2	APVD PROD ENGRG	DRAWING NUMBER 03-460-220	REV J
DRN JRA 06-27-03	APVD ENGRG SH	CUSTOMER COPY	