

CAUTION:

OILS CONTAINING SLIPPERY OR ANTI-WEAR ADDITIVES, SUCH AS GRAPHITE OR MOLYBDENUM DISULFIDE, OR EXTREME PRESS. (E. P.) TYPE LUBRICANTS SHOULD NOT BE USED, THESE LUBRICANTS MAY ALLOW THE BRAKE TO SLIP AT TORQUE LEVELS BELOW THE RATED VALUES.

PART NUMBER
13-602-010
NPI OR ECN NO.
ECO S-1703

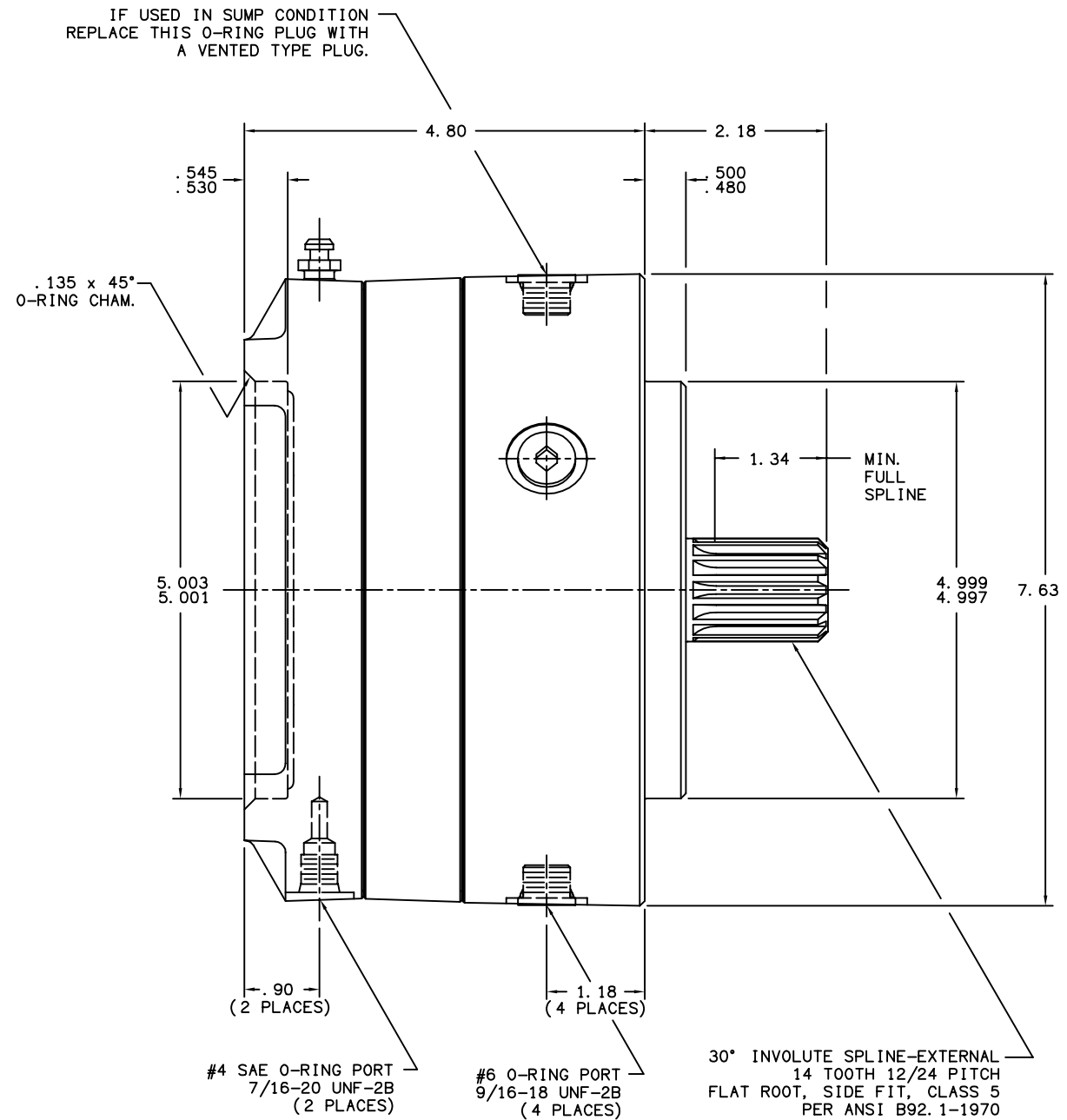
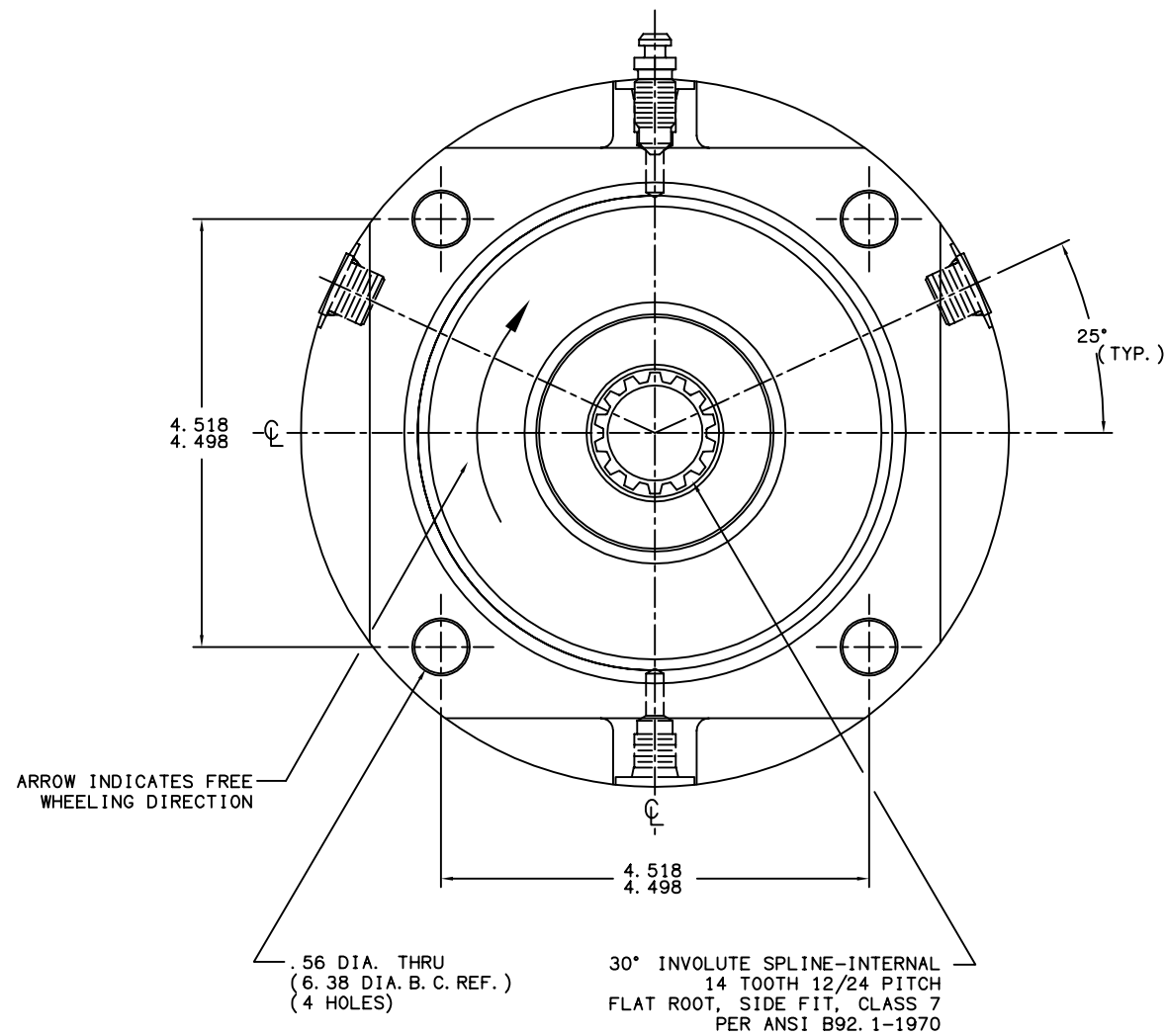

NOTES:

- 1.) LINING REPAIR KIT P/N 12-501-214
- 2.) BEARING REPAIR KIT P/N 12-501-094
- 3.) O-RING REPAIR KIT P/N 12-501-295
- 4.) SPRING REPAIR KIT P/N 12-501-294

SPECIFICATIONS:

TYPE: WET MULTIPLE DISC BRAKE, (WITH ONE WAY CLUTCH)
SPRING APPLY, HYDRAULIC RELEASE

TORQUE RATING: 6,500 LB-IN STATIC (BREAKAWAY) AT 0 PSI BACK PRESSURE

RELEASE PRESSURE: 220 PSI INITIAL, 300 PSI FULL

MAXIMUM OPERATING PRESSURE: 3,000 PSI

MAXIMUM SPEED: NON-FREE WHEELING DIRECTION: (FLOW THRU) 4,000 RPM (SUMP) 3,000 RPM
FREE WHEELING DIRECTION: (FLOW THRU & SUMP) 4,000 RPM

LINING MATERIAL: METALLIC GRAPHITIC

APPROXIMATE WEIGHT: 42 LBS.

FOR USE WITH MINERAL BASE HYDRAULIC OIL ONLY.

COOLING OIL RECOMMENDATIONS:

OIL TYPE: MINERAL BASE HYDRAULIC OIL SUCH AS MOBIL DTE 24, CITGO A/W 32 OR EQUIVALENT

FLOW THRU CAPACITY: 1.0 - 7.0 GPM

MAXIMUM CASE PRESSURE: 30 PSI

SUMP OIL VOLUME: 6 FL. OZ.

BRAKE IS DESIGNED FOR HORIZONTAL USE ONLY



COMPONENT AND SYSTEM RECOMMENDATIONS MADE BY MICO, INC. ARE BASED ON INFORMATION SUPPLIED BY POTENTIAL USER AND/OR SYSTEM DESIGNER. THE POTENTIAL USER AND/OR DESIGNER MUST MAKE FINAL ACCEPTANCE AND APPROVAL OF COMPONENTS AND SYSTEM AFTER TESTING PERFORMANCE ON AN ACTUAL APPLICATION FOR WHICH SYSTEM WAS DESIGNED.

MICO, INC. CLAIMS PROPRIETARY RIGHTS TO THE MATERIAL DISCLOSED IN THIS DOCUMENT. THIS DOCUMENT IS PROVIDED IN CONFIDENCE AND MAY NOT BE REPRODUCED OR DISCLOSED WITHOUT WRITTEN PERMISSION FROM MICO, INC. COPYRIGHT MICO, INC. ALL RIGHTS RESERVED.

TITLE		WINCH BRAKE 3CWC-141465-CCC	
SCALE	CHECKED	PART NUMBER	REV
1:2	LH 08/29/03	13-602-010	D
DRN G. J. 11/14/01	APP ENG GAA 08/29/03	CUSTOMER COPY	