

**CAUTION:**

OILS CONTAINING SLIPPERY OR ANTI-WEAR ADDITIVES, SUCH AS GRAPHITE OR MOLYBDENUM DISULFIDE, OR EXTREME PRESS. (E. P.) TYPE LUBRICANTS SHOULD NOT BE USED, THESE LUBRICANTS MAY ALLOW THE BRAKE TO SLIP AT TORQUE LEVELS BELOW THE RATED VALUES.

PART NUMBER  
13-602-032  
NPI OR ECN NO.  
ECN000128

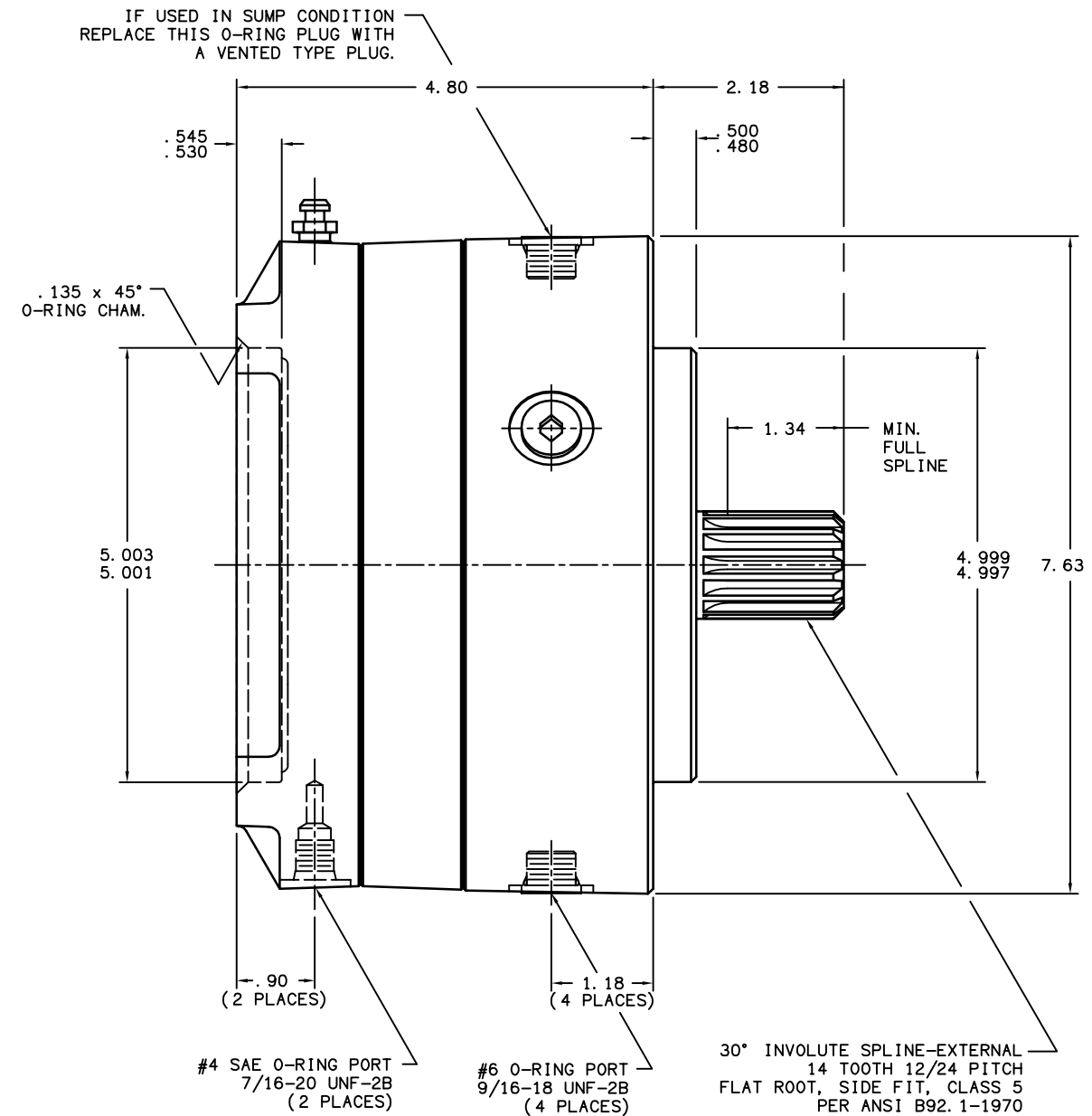
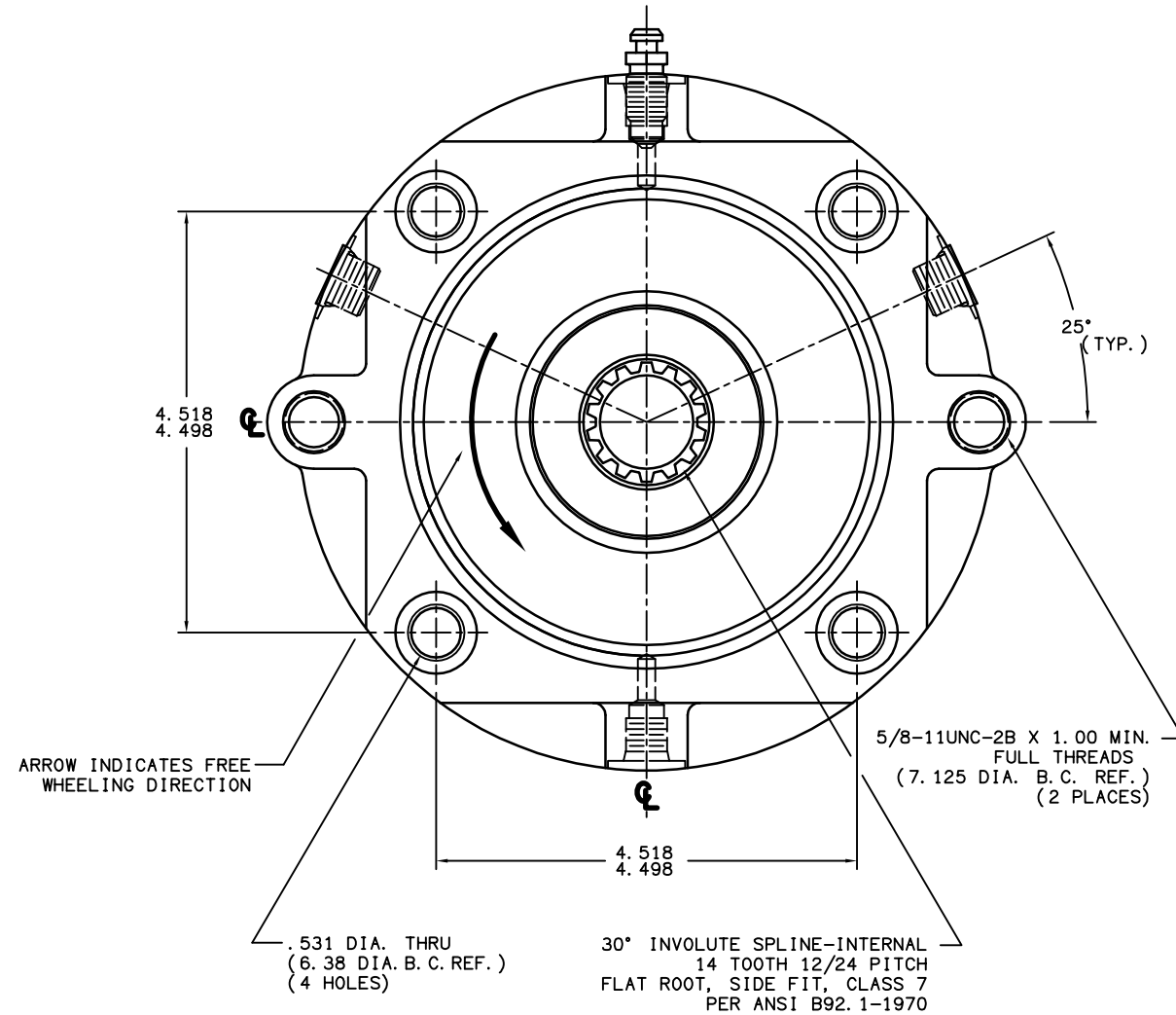

**NOTES:**

- 1.) LINING REPAIR KIT P/N 12-501-214
- 2.) BEARING REPAIR KIT P/N 12-501-094
- 3.) O-RING REPAIR KIT P/N 12-501-295
- 4.) SPRING REPAIR KIT P/N 12-501-294

**SPECIFICATIONS:**

<b>TYPE:</b>	WET MULTIPLE DISC BRAKE, (WITH ONE WAY CLUTCH) SPRING APPLY, HYDRAULIC RELEASE
<b>TORQUE RATING:</b>	4,000 LB-IN STATIC (BREAKAWAY) AT 0 PSI BACK PRESSURE
<b>RELEASE PRESSURE:</b>	140 PSI INITIAL, 190 PSI FULL
<b>MAXIMUM OPERATING PRESSURE:</b>	3,000 PSI
<b>MAXIMUM SPEED:</b>	NON-FREE WHEELING DIRECTION: (FLOW THRU) 4,000 RPM (SUMP) 3,000 RPM FREE WHEELING DIRECTION: (FLOW THRU & SUMP) 4,000 RPM
<b>LINING MATERIAL:</b>	METALLIC GRAPHITIC
<b>APPROXIMATE WEIGHT:</b>	42 LBS.
FOR USE WITH MINERAL BASE HYDRAULIC OIL ONLY.	

**COOLING OIL RECOMMENDATIONS:**

**OIL TYPE:** MINERAL BASE HYDRAULIC OIL SUCH AS MOBIL DTE 24, CITGO A/W 32 OR EQUIVALENT  
**FLOW THRU CAPACITY:** 1.0 - 7.0 GPM  
**MAXIMUM CASE PRESSURE:** 30 PSI  
**SUMP OIL VOLUME:** 6 FL. OZ.  
 BRAKE IS DESIGNED FOR HORIZONTAL USE ONLY



COMPONENT AND SYSTEM RECOMMENDATIONS MADE BY MICO, INC. ARE BASED ON INFORMATION SUPPLIED BY POTENTIAL USER AND/OR SYSTEM DESIGNER. THE POTENTIAL USER AND/OR DESIGNER MUST MAKE FINAL ACCEPTANCE AND APPROVAL OF COMPONENTS AND SYSTEM AFTER TESTING PERFORMANCE ON AN ACTUAL APPLICATION FOR WHICH SYSTEM WAS DESIGNED.		MICO, INC. CLAIMS PROPRIETARY RIGHTS TO THE MATERIAL DISCLOSED IN THIS DOCUMENT. THIS DOCUMENT IS PROVIDED IN CONFIDENCE AND MAY NOT BE REPRODUCED OR DISCLOSED WITHOUT WRITTEN PERMISSION FROM MICO, INC. COPYRIGHT MICO, INC. ALL RIGHTS RESERVED.	
TITLE WINCH BRAKE 3CWC-141440-C24CW			
SCALE 1:2	CHECKED	PART NUMBER 13-602-032	REV E
DRN G. J. 05/29/03	APP ENG	CUSTOMER COPY	