

Reverse Modulating Brake Valves, Circuit Design Considerations and Applications

R.P. Middendorf and D.E. Keyser

MICO, Inc.
1911 Lee Boulevard
North Mankato, Minnesota 56003

SAE TECHNICAL PAPER 920908

ABSTRACT

Spring apply, hydraulic release (SAHR) brake circuits can provide service, emergency, and parking brake functions, requiring less hardware as compared to a conventional hydraulically actuated brake circuit. However, the spring apply, hydraulic release brakes also require unique control circuits.

Brake system components must be selected based on the unique features of spring apply hydraulic release brakes. Each component will affect the overall performance of the brake system. This paper will discuss design prerequisites, circuit design considerations, component selection and brake design considerations.

Spring applied hydraulic release brake systems are becoming increasingly important to off-highway equipment designers and engineers. For this reason it is important to understand the difference between the conventional hydraulic brake actuation system and the spring applied hydraulic release brake actuation system.

To obtain brake performance as recommended by the many accepted brake standards (Ref. 1), a conventional hydraulic brake actuation system may require independent service, secondary, and parking brake circuits to provide braking in the event of any single failure in the service brake system. Service brake actuation systems are commonly split to add redundancy to a system. This method produces 50% service braking with any single brake circuit failure. In addition, parking functions typically require an independent brake and a separate method of actuation. The complexity of such systems will be apparent when you consider the number of valves, switches, hoses and connectors that are involved.

Spring apply, hydraulic release brake systems, on the other hand, may consist of a single circuit, providing service, secondary and parking functions with a common brake(s). The actuation circuit used to control this brake will require limited control hardware and plumbing. Consequently, this brake system will be easy to maintain, troubleshoot and is cost effective.

DESIGN PREREQUISITES

Typically, brakes or axles with the brakes incorporated are sized for mobile equipment prior to designing the brake actuation system. Therefore, for the purpose of this paper, it is assumed that a functional brake, with the proper torque capacity, has been selected. To effectively design the actuation portion of the brake circuit, the following criteria must be known: (1) pressure requirement of the brake, (2) volume requirement of the brake, (3) input pedal force requirement, (4) actuation (response) time, and (5) secondary and parking requirements.

PRESSURE REQUIREMENT - As the name implies, the spring applied hydraulic release brake is mechanically actuated by springs and is dependant on hydraulic pressure to keep it released. Therefore, the brake actuation circuit, in a normal released mode, must maintain sufficient pressure to allow the spring applied hydraulic release brake to fully release. The reverse modulating brake valve regulates this pressure to a safe level above the "full release pressure" of the brake. The brake, in a full release condition, has maximum running clearance between the rotating and stationary plates. "Initial release pressure" refers to the brake condition where the rotating and stationary plates make initial contact and minimal torque is developed. "Full apply pressure" suggests a maximum brake applied condition, normally occurring at zero pressure.

The full release pressure, initial release pressure and full apply pressure must be determined prior to design of the brake actuation circuit. This information is available from the brake manufacturer.

VOLUME REQUIREMENT - The oil volume capacity of the brake must also be determined prior to brake actuation circuit design. Volume requirements may be referred to in terms of maximum (worn) brake and normal (new) brake displacement. As the brake lining material wears, piston travel increases. Brake system components such as the accumulator, hoses, and valves will be sized according to this brake volume requirement.

PEDAL FORCE - Input pedal force may be expressed as a maximum value required to generate the maximum brake torque. There are governing agencies that make recommendations to assist in identifying this maximum value, (Ref 1). More importantly, the pedal effort must comply with the operator's ability to effectively control the machine. The brake valve pedal ratio, piston diameter and springs may be selected to obtain the desired effort.

RESPONSE TIME - Response time or actuation time with respect to spring applied hydraulic release brake system, is a time interval initiated by pedal movement, resulting in a full brake application. This is directly related to brake volume, pressure and plumbing size, and will affect the stopping parameters of the machine. Oil must be exhausted quickly from the brake and the actuation circuit to reduce the response time and optimize braking performance.

SECONDARY / PARKING - The secondary (emergency) and parking features of the brake actuation circuit must be reviewed. In the case of emergency braking, a "failure mode analysis" will help determine component selection. As an example, if the energy source (brake pump) became disabled, and there were no provisions to maintain brake system pressure, the brakes will be energized and bring the machine to an uncontrolled stop. However, if an accumulator is used, reserve oil stored in the accumulator will be available to bring the machine to a controlled stop by actuating the service brake pedal. In this case, a valve could be installed to provide the emergency braking.

Parking function can be controlled with a manual or solenoid operated two position valve. These valves would be incorporated in the system in such a manner that when actuated the brake system pressure would be dumped causing the brakes to apply.

There is further discussion on secondary and parking circuits later in this paper.

CIRCUIT DESIGN CONSIDERATIONS

This section will very briefly discuss brake actuation circuits and how they are integrated into open center, closed center and load sensing hydraulic systems. Although these three are the most commonly used, the possibilities are limitless.

POWER BRAKE SYSTEMS - In each of the system schematics 1, 2, and 3, the brake actuation circuits will differ only relating to the charging of a brake accumulator. This is relative to the type of system they are integrated with. As shown in these schematics the brake actuation circuit is considered as closed center. In a spring applied hydraulic release brake actuation circuit the primary purpose of the accumulator is to provide controlled braking in the event the energy source (pump) becomes disabled.

Open Center - As is the case with any full power hydraulic brake actuation system, it is possible to use either a dedicated brake pump or divert oil from other hydraulic sources on the machine (this could be referred to as a non-dedicated pump). Accumulator charging valves, are commonly used to divert oil in an open center circuit as shown on schematic #1. This charging valve will regulate the oil at a predetermined volume and pressure to the accumulator on demand. The selection of this valve can be such that a very small amount of oil is diverted for accumulator charging, so it does not interfere with the operation of downstream devices. Typically the downstream devices do not interfere with the operation of the charging valve.

The charged accumulator supplies pressurized fluid to the reverse modulating brake valve. The reverse modulating power brake valve is used for modulating the pressure in the brake system by increasing or decreasing pressure in the brake system in direct proportion to the input force from the operator via the brake pedal.

**SYSTEM SCHEMATIC 1
CLOSED CENTER ACTUATION CIRCUIT/
OPEN CENTER CHARGING SYSTEM**

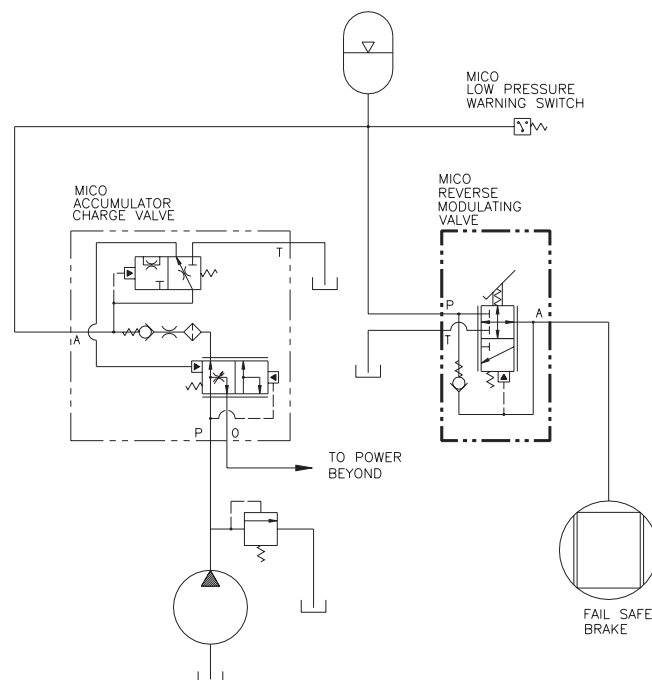

Closed Center - Pressure compensated systems may provide fluid for the spring applied hydraulic release braking circuit as shown on system schematic #2. This dedicated pressure compensated system may include an isolation check valve in place of the accumulator

charging valve. The check valve will prevent accumulator pressure loss in the event of an energy source failure. The events of brake actuation are then identical to those listed previously under the open center circuit.

**SYSTEM SCHEMATIC 2
CLOSED CENTER ACTUATION CIRCUIT/
PRESSURE COMPENSATED SYSTEM**

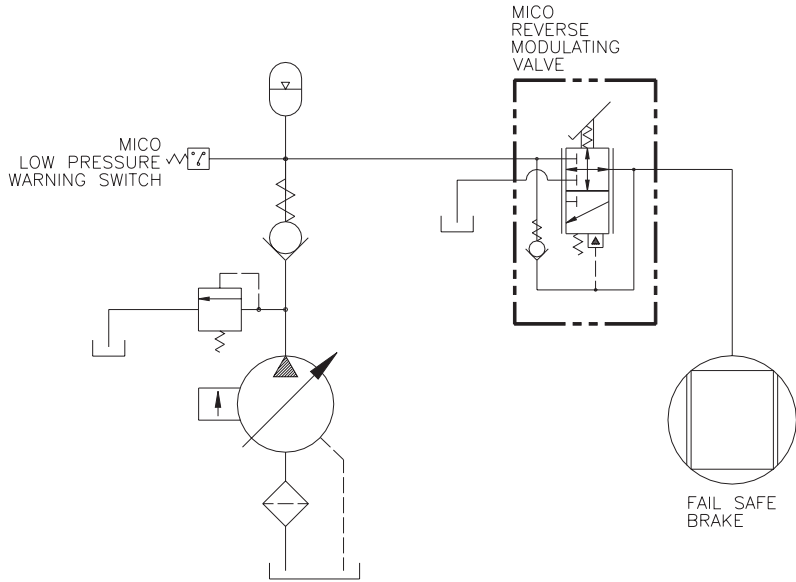

Load Sense - Pressure compensated/load sense systems may include a load sense accumulator charging valve to charge the brake accumulator as shown on system schematic #3. Load sense circuits are very similar to open center circuits with respect to the required

components. In open center and load sense circuits, the accumulator also maintains reserve volume and pressure in the system allowing the accumulator charging valve to unload the pump.

**SYSTEM SCHEMATIC 3
CLOSED CENTER ACTUATION CIRCUIT/
LOAD SENSE CHARGE SYSTEM**

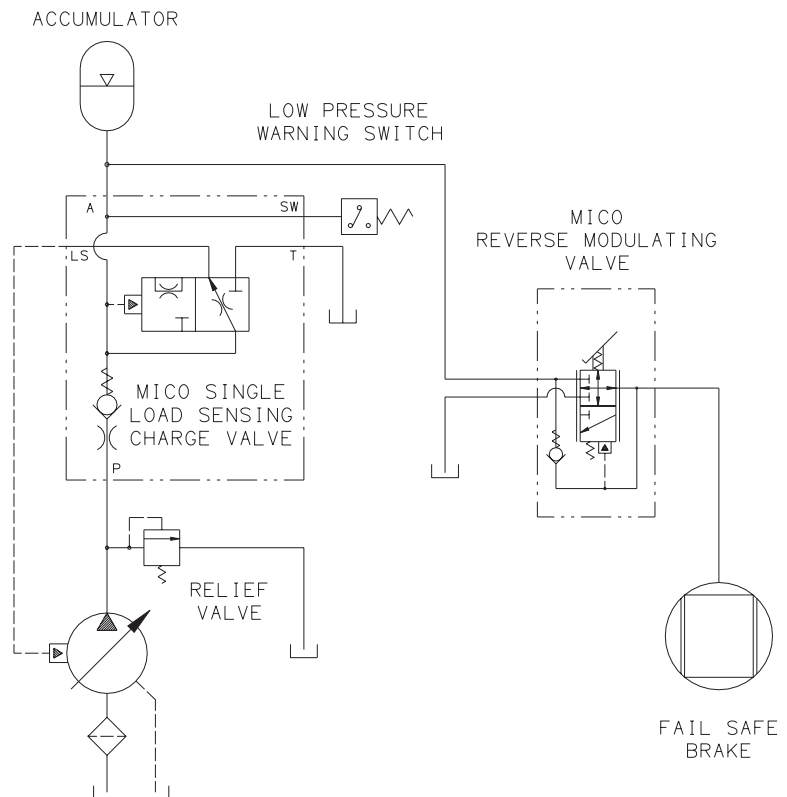

COMPONENT SELECTION

Proper selection of components for a full power hydraulic brake system begins with the integration process previously discussed.

The advantages and disadvantages of various pump designs are beyond the scope of this paper. It is important however, that brake system designers be informed about various pump capabilities while evaluating methods of supplying oil to brake actuation circuits. System schematics 1, 2, and 3 suggest examples of how a pump may supply oil for a closed center brake actuation circuit.

The brake actuation circuits discussed include a reverse modulation valve, low pressure warning switch, accumulators, relief valve, and park secondary valve.

REVERSE MODULATING VALVES - As previously mentioned in the discussion on open center system and brake actuation circuit integration, pressure modulation control for service braking may be controlled by a reverse modulating valve. The term "reverse modulating" is used because pressure is decreased to actuate the brake from a preset pressure that keeps the brake fully released. The preset pressure is regulated to a level above the full release pressure of the brake and must be maintained to assure that brake drag does not occur.

Description and Operation - Two types of closed center MICO reverse modulating valve designs, "poppet valves", figure A, and "spool valves", figure B, will be discussed. Both valves are shown in the release position (pressure to the brake), with pressure being supplied to the valve. In this position, a preset load on the regulating spring is balanced by the hydraulic load generated by the brake pressure working against the piston (spool). In the case of the "poppet valve", the poppet controls fluid movement through the valve. With the "spool valve", the spool controls this function. In the released position, fluid is held on the brake and pressure is maintained until the pedal is depressed. The bias spring provides a preloaded force above that of the regulating spring, thus maintaining the hydraulic/force balance.

When brake actuation is needed, the pedal is depressed, pulling on the shaft and compressing the bias spring, reducing the load on the regulating spring. As regulating spring force is reduced, the piston (spool) opens to the tank cavity and reduces pressure to the brake. If pedal movement stops, the piston (spool) will compensate as necessary to provide the new pressure level. Brake pedal position and force is proportional to the brake line pressure which provides the braking feel, necessary for proper machine braking control. The "pedal operating range"

FIGURE A
REVERSE MODULATING
"POPPET VALVE"
SHOWN IN RELEASED POSITION
(PRESSURIZED SYSTEM)

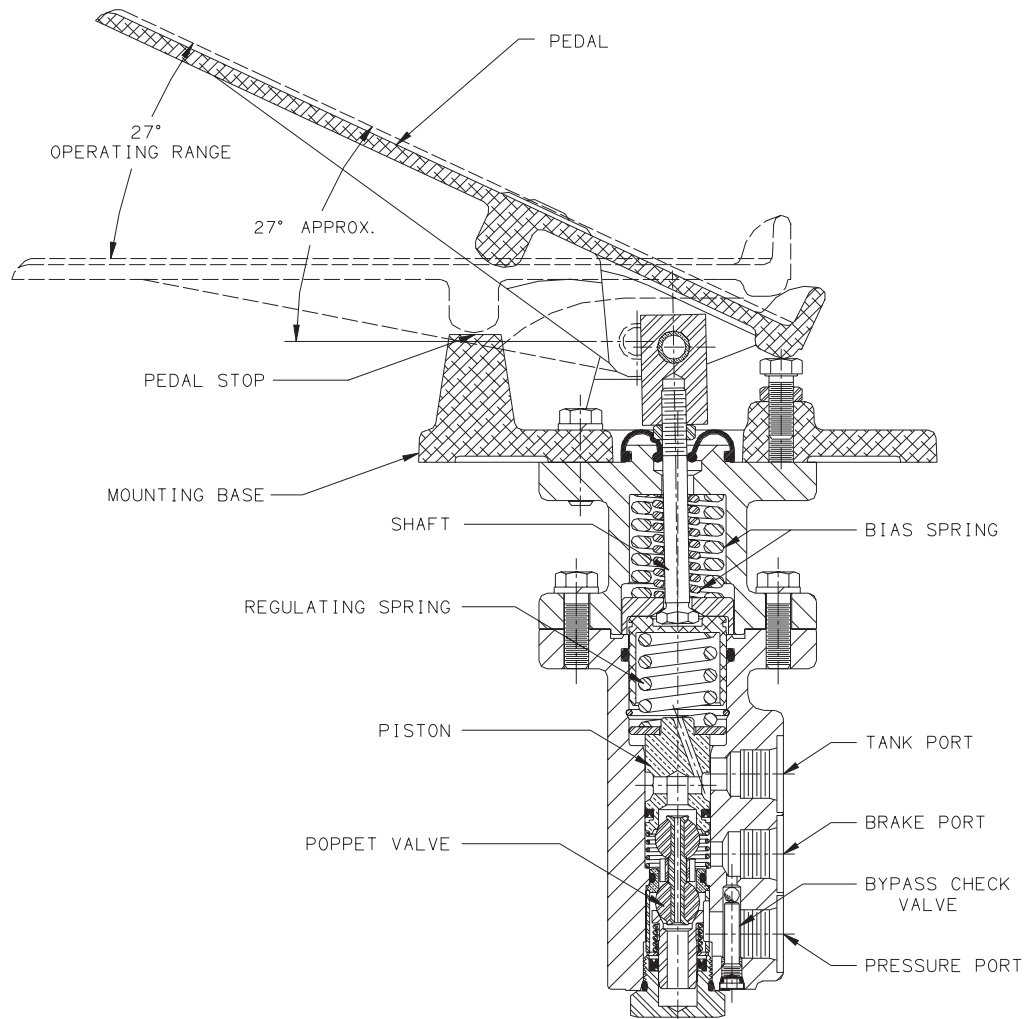
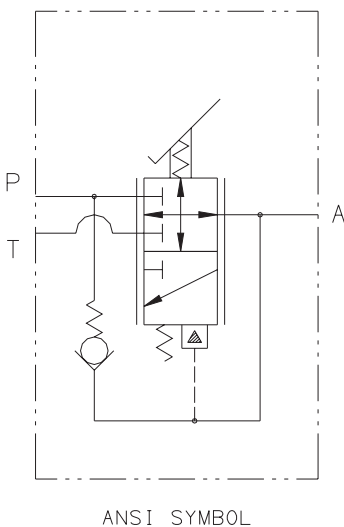
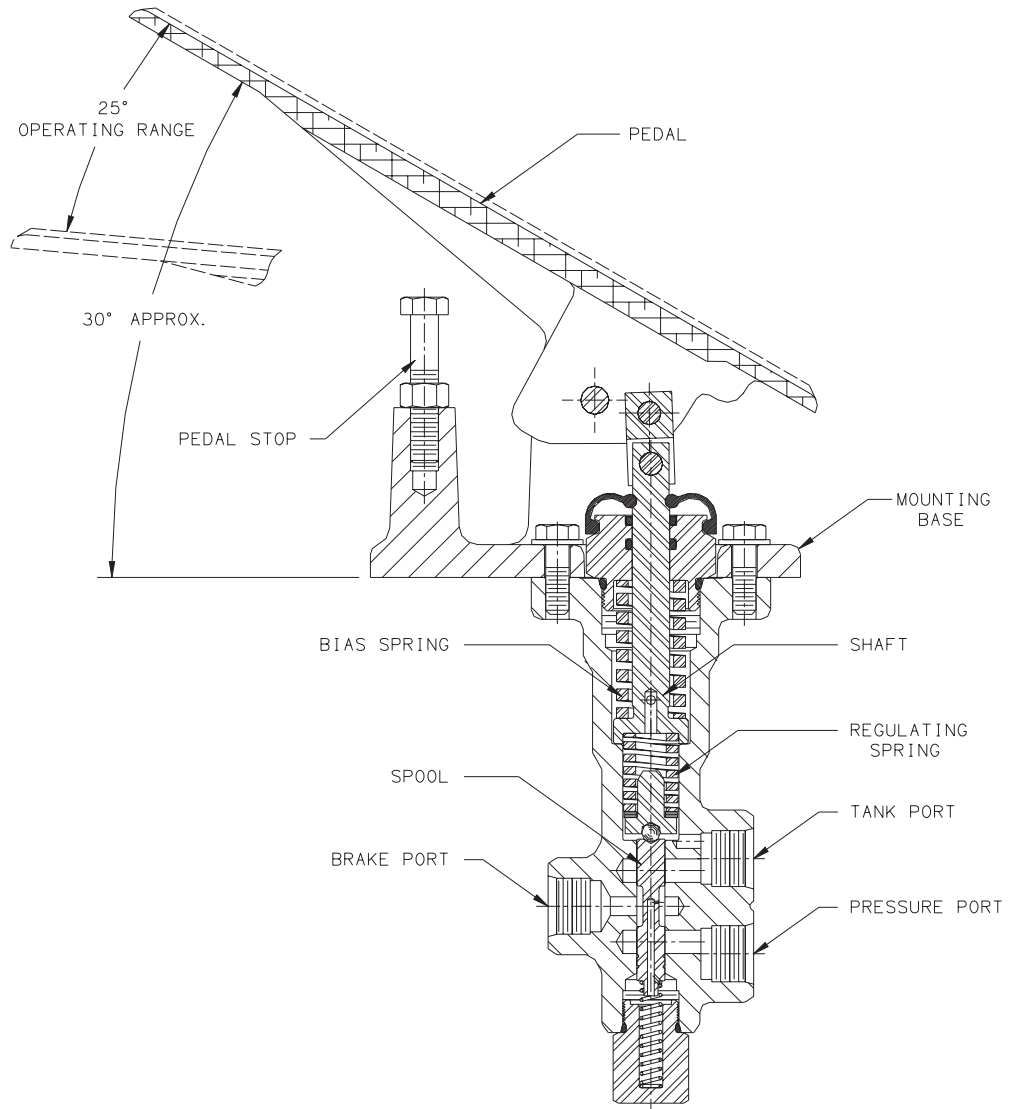
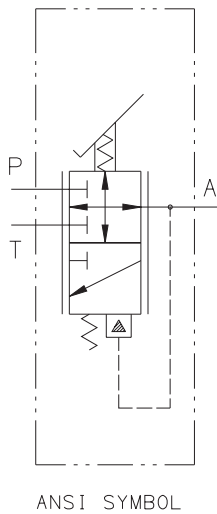

FIGURE B
REVERSE MODULATING
"SPOOL VALVE"
 SHOWN IN RELEASED POSITION
 (PRESSURIZED SYSTEM)



represents the modulated pedal travel plus free travel. Free travel provides a brake to tank free flow of oil at the end of the pedal travel for accelerated brake actuation.

The "poppet valve", when in the released position, has near zero leakage from the pressure port to the tank, and from the brake port to the tank. Because of this condition a "bypass check valve" has been incorporated, allowing the brake circuit to bleed down during a supply pressure reduction, thus providing secondary braking. Because of the high flow-through capability of the poppet valve, it is recommended for large volume brake systems.

The "spool valve" has smaller internal passages so it should be used in low volume brake systems. The internal spool has a narrow overlap position where the brake port is blocked to the pressure port and the tank port. The spool has no seals so leakage is controlled by the diametrical clearance between the spool and housing and the overlap distance. In a low brake volume system, pressure will fall quickly so a "bypass check valve" may not be necessary as it is with the poppet style valve. This situation must be reviewed as it pertains to a specific brake system.

LOW PRESSURE WARNING SWITCH - In any of the three types of systems, a low pressure warning switch may be incorporated to signal a brake system failure. This signal would appropriately warn the operator prior to an emergency brake application. The switch should be set above the full release pressure of the brake.

ACCUMULATOR - As discussed earlier, the accumulator has two purposes in the spring applied hydraulic release brake system.

- 1) To provide reserve oil for power-off controlled braking. If an accumulator is not used, an energy source (brake pump) loss will result in an uncontrolled stop of the machine.
- 2) The accumulator, when used in an open center or load sense system with a charging/unloading valve provides the reserve volume and pressure necessary for pump unloading.

The accumulator should be of adequate size to accommodate the volume and leakage conditions of the brake system. In the case of item "2" above it is necessary that the accumulator have sufficient oil volume between the high and low limits of the charging valve to minimize the charging cycles. Accumulator oil capacity, dry nitrogen precharge pressure, and the initial oil pressure must be evaluated to limit charge cycle frequency, thus reducing heat and enhancing pump life, (Ref. 2).

**SYSTEM SCHEMATIC 4
CLOSED CENTER ACTUATION CIRCUIT with
PARK SECONDARY VALVE / OPEN CENTER
CHARGE SYSTEM**

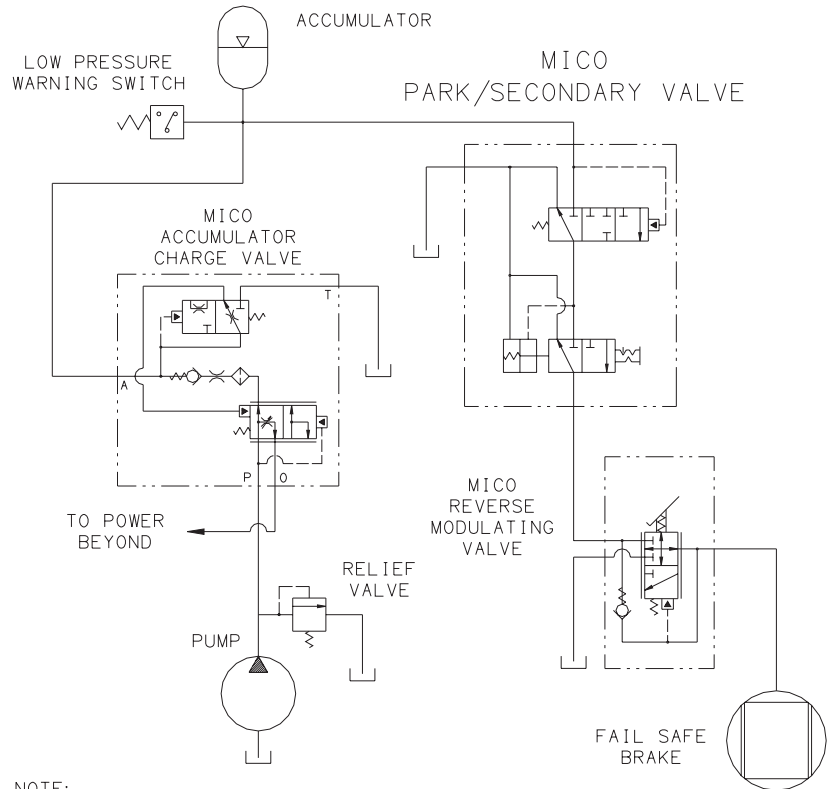

NOTE:

THIS DIAGRAM DEPICTS A BRAKING SYSTEM WHICH MAY BE CLAIMED IN UNITED STATES PATENT NO. 4,893,879 WHICH IS NEITHER OWNED NOR LICENSED BY MICO, INCORPORATED.

RELIEF VALVE - The relief valve must be incorporated into the system to protect the pump and other controls from overpressurization.

The relief valve must be capable of handling the full pump displacement and the required pressure for the actuation system.

PARK/SECONDARY BRAKE VALVE - Parking and emergency functions may be easily integrated into a spring applied hydraulic release brake actuation system. A typical solenoid or manual two-position three-way directional valve may be used to control parking functions. Emergency braking is a direct response to a loss of pressure so a secondary control valve may not be necessary. System schematic #4 illustrates a MICO park/secondary control valve which has been incorporated to provide two functions.

1.) A two-position three-way valve for manual-park actuation of the brake: This could be a modulated valve or the on/off valve as shown. When this valve is shifted to the apply position, the brake is opened to the tank and the pressure supply is blocked. In this apply position, the brake may remain actuated for an indefinite period of time, with or without supply pressure from the accumulator.

2.) A trigger valve to allow an automatic emergency actuation of the brake system when accumulator pressure drops below a predetermined level: Although it was previously noted that this function may not be necessary, there are certain government regulations that may require this feature due to stopping time restrictions,

(Ref. 3). Accumulator pressure decline will produce brake pressure decline (actuation) through the reverse modulating valve. However, if it is necessary that the brake system apply fully at a specific pressure level during a hydraulic failure situation this type of valve may be required.

BRAKE DESIGN CONSIDERATIONS

Spring applied hydraulic release brakes have been developed for use in off-highway applications (ref. 4). Two brake design considerations that could affect circuit performance are low pressure modulation and brake dead band. Brake release for towing is also a consideration.

LOW PRESSURE MODULATION - Many spring apply hydraulic release brakes have been designed with low release pressure so full brake release can be attained using the typical charge pump on a hydrostatic transmission. Many of these brakes are designed for and are intended for parking applications only. However, some may be used for dynamic service braking purposes, in addition to serving as a parking brake. It should be noted that the low release pressure these brakes are designed to operate at may produce poor modulating performance for the following reasons:

1) Low pressure modulating capability of the brake valve: The selection of a brake valve must be made based on its ability to regulate low pressure. This situation also relates to the brake's ability to respond effectively at low pressure.

The MICO "poppet valve" large piston diameters are

incorporated to increase the hydraulic reaction force necessary for good low pressure modulation.

2) Brake torque delay due to restrictions: Low pressure brake response is also a factor of the brake and brake system's ability to exhaust oil (actuation). This situation is opposite that of a pressure apply system where oil is forced into the brake from a high pressure source to develop torque. In a spring applied hydraulic release brake the internal springs used to develop

torque are forcing oil from the brake, through the modulating valve, to tank. This difficulty will be most apparent as pressure approaches zero. This condition may result in a pressure and brake torque delay.

The reverse modulating valve, hoses, and connectors must be sized to improve this situation. Decreasing pressure drop through the brake system will reduce the actuation (response) time and improve performance, (Ref. 5).

FIGURE C
WHEEL MOUNT MULTIPLE DISC BRAKE
Piston travel and running clearance illustration

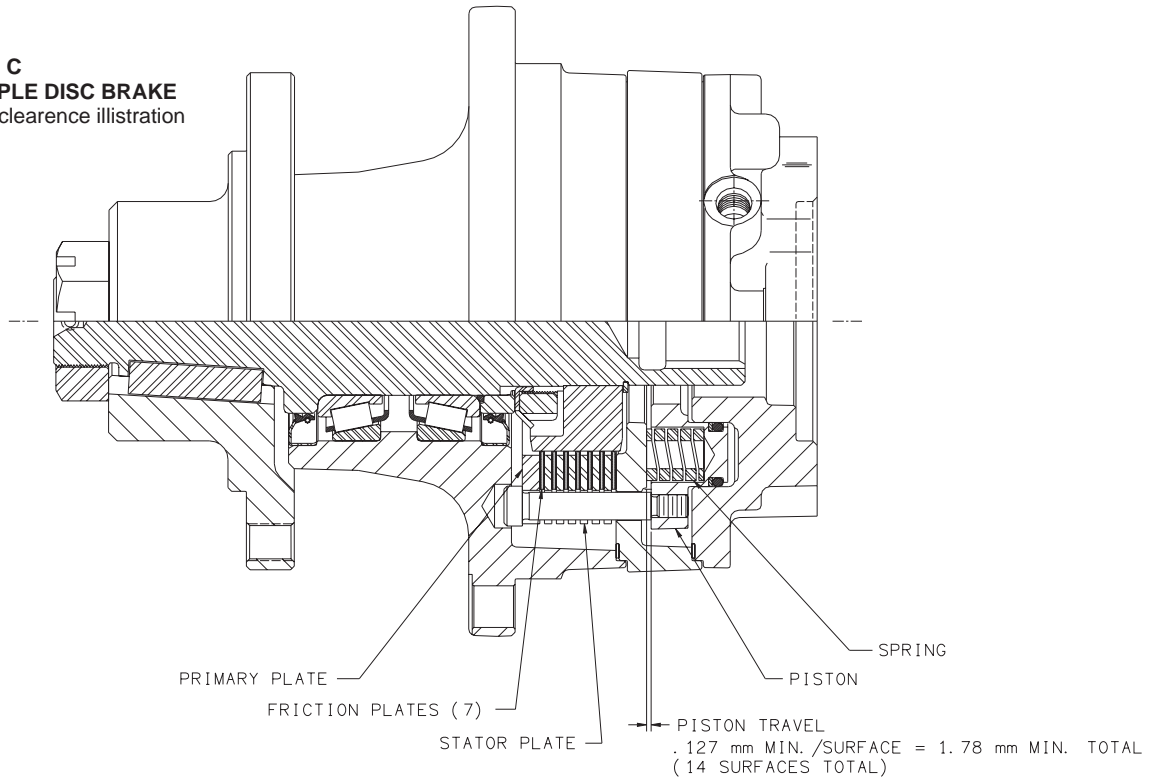

BRAKE DEAD BAND - All spring applied hydraulic release multiple disc brakes have a pressure dead band which may be identified by full release pressure minus initial release pressure. Initial release refers to the pressure level required to lift the piston from the lining stack. Initial torque is generated at this point. Full release refers to the pressure level required to fully advance the piston, giving running clearance to the plates. The total lining clearance is equal to the piston travel as shown on Figure C. Most of the brake volume is created by the piston travel between initial and full release. When the reverse modulating valve is actuated, this volume must be exhausted from the brake before developing torque. This may cause volume related delay. The modulating valve must be set above full release pressure of the brake. This valve setting minus the initial release pressure of the brake determines the pressure dead band of the system.

Example

Brake full release pressure 100 bar
Brake initial release pressure 90 bar
Reverse modulating valve setting 110 bar
110 bar - 90 bar = 20 bar dead band
20 bar / 110 bar = 18% pressure dead band

In terms of modulation, the initial 18% of the modulated pedal travel will produce no brake torque.

Although, braking system performance may be optimized by properly selecting and sizing components, as previously discussed, brake performance must also be reviewed in terms of a new brake and a worn brake. Specifications will change with the life of the brake.

BRAKE RELEASE FOR TOWING - When a spring applied hydraulic release brake system becomes disabled and accumulator reserve oil is depleted, a secondary hydraulic source may be required to release the brake. In some cases, an emergency mechanical release mechanism is incorporated as a part of the spring applied hydraulic release brake, eliminating the need for this secondary hydraulic system.

CONCLUSIONS

The spring applied hydraulic release brake system is a simple alternative to the conventional hydraulic actuation brake system, assuming that proper selection and sizing of components has been addressed. Service, secondary, and parking functions may be obtained through one simple actuation circuit resulting in a reliable, cost effective system. However, because there are no regulatory standards issued by the governing agencies it is difficult to evaluate the performance of spring applied , hydraulic released brake actuation circuits. Adaptations of existing SAE recommendations may be required by the designer to provide a safe functional brake actuation circuit.

REFERENCES

- 1) "Braking Performance-Rubber Tired Earthmoving Machines", SAE J1473, DEC84
- 2) Parker Hannifin Fluid Power Bulletins: Analyzing Hydraulic Systems- #0222 and Fluid Power 2- #0226
- 3) Department Of Labor, Mine Safety and Health Administration, 30 CFR Part 75, Automatic Emergency-Parking Brakes
- 4) G.T. DeWald "Design Considerations of Spring Apply - Hydraulic Release Liquid Cooled Service Brakes for Off- Road Use", SAE paper no. 920907, presented at the Earthmoving Industry Conference, Peoria, IL, April, 1992.
- 5) Parker Hannifin Fluid Power Bulletin: Design Engineers Handbook- #0224