



# PRODUCT BULLETIN

## Electrohydraulic 691 Brake Lock System (supplemental brake holding device)

### DESCRIPTION

MICO® Brake Lock Systems lock hydraulic pressure in the service brakes to supplement the vehicle's mechanical parking brake and provide extra holding in heavy-duty and high-frequency applications. The 691 consists of a small electrohydraulic pump, remote mounted actuator (single and/or dual), electronic control module and small dash-mounted user interface. The operator simply activates a switch and the 691 system automatically applies, monitors, and maintains brake locking pressure.

The 691 Brake Lock significantly enhances vehicle-holding capability while not interfering with normal service brake function and provides added safety for operator, vehicle, and work area.

In addition to operator control via the "Lock/Release" switch on the user interface, 691 systems can be remotely controlled and/or interlocked using leads in the main wiring harness. This allows control of the brake lock system from locations outside the cab. As an interlock, 691 operation is linked to other vehicle systems and components; for example, wheelchair lift, PTO, electrical generator, hydraulic pump, air compressor, etc. to ensure that whenever they are being used the brakes are locked and the vehicle is immobilized.

### FEATURES

- Supplements existing parking brake for additional holding
- Automatically monitors and maintains optimal brake lock system pressure
- Activates with the flip of a switch
- Can be remotely controlled
- Can be interlocked with other 12-volt systems
- Microprocessor controlled with onboard diagnostic LED's
- Waterproof control module
- Factory provided weatherproof connectors
- Wide selection of models



This document is intended to provide general information about MICO Products. MICO, Inc. has attempted to present accurate information about MICO Products in its catalogs, brochures, and other printed materials. MICO, Inc. is not responsible for errors, inaccuracies, or inconsistencies that may exist in any catalog brochure or other printed materials or any damages arising from or related to reliance on information in them. Materials and specifications for MICO Products set forth in catalogs, brochures, and other printed materials are subject to change without notice or obligation. Refer to [www.mico.com](http://www.mico.com) for the most recent versions of our literature. If you have any questions concerning MICO Products, please contact MICO, Inc. All MICO Products and service are sold and provided subject to the MICO Warranty at [www.mico.com](http://www.mico.com) in effect on the date of sale or supply.

MICO is a trademark and registered trademark of MICO, Inc. MICO is registered in the U.S. Patent and Trademark Office as well as in Australia, Canada, Indonesia, Japan, Peoples Republic of China, South Korea, and the European Community.



### MICO, Inc.

1911 Lee Boulevard  
North Mankato, MN U.S.A. 56003-2507  
Tel: +1 507 625 6426 Fax: +1 507 625 3212

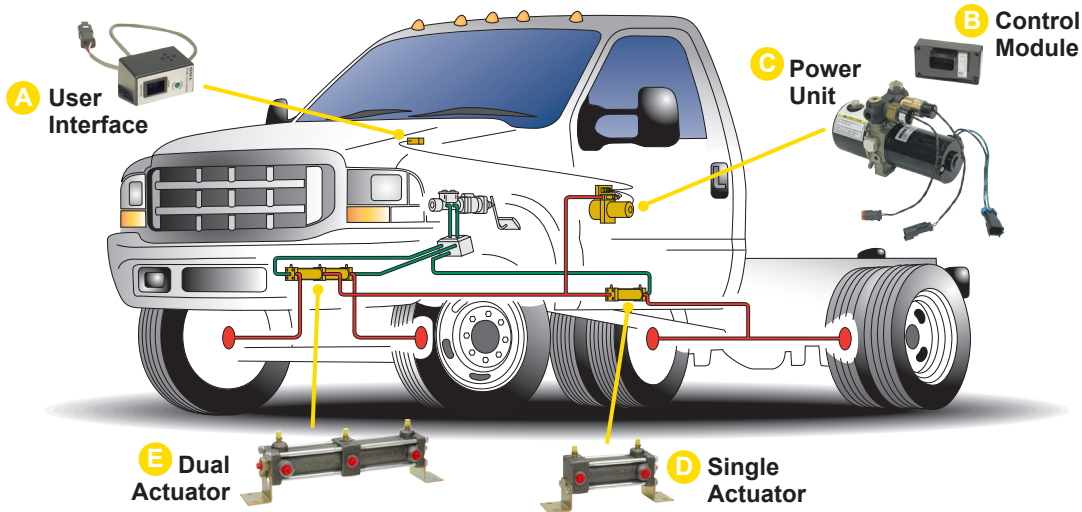

**A User Interface:** provides operator access for controlling and monitoring 691 operation. It contains a recessed rocker switch, an audible alarm, and an indicator lamp. Located in cab. **NOTE: In place of the user interface, controls similar to those already in the cab can be used to achieve a finished OEM appearance. 691 Systems can also be remotely controlled by switches located outside the cab, or interlocked with other 12-volt systems.**

**B Control Module:** the electronic processor that evaluates input signals and manages all 691 system functions. Utilizing the user interface and vehicle horn, the Control Module informs the operator visually and audibly of system conditions. LED's on the module indicate system status and operating modes. Can be mounted directly to the power unit using supplied bracket and fasteners, or remotely mounted. An optional wiring harness extension is available when remote mounting is desired.

**C Power Unit:** pressurizes and holds system pressure when activated. Two pressure switches send signals to the control module indicating the current pressure conditions. If correction is necessary, the 691 Power Unit will compensate system pressure accordingly. Upon deactivation, the 691 Power Unit reverses flow to release locking pressure. Located under hood, behind seat, or on the vehicle frame rail.

**D Single Actuator:** used for connecting to one brake line controlled by a single input from 691 Power Unit. Single Actuators are available in two different bore sizes and are capable of displacing 1.77-2.90 in<sup>3</sup> of brake system fluid. Usually mounted on a vehicle frame rail.

**E Dual Actuator:** used for connecting to two brake lines controlled by a single input from 691 Power Unit. Dual Actuators are available in two different bore sizes and are capable of displacing 1.77-2.90 in<sup>3</sup> (per side) of brake system fluid. Usually mounted on a vehicle frame rail.

**A 691 User Interface**

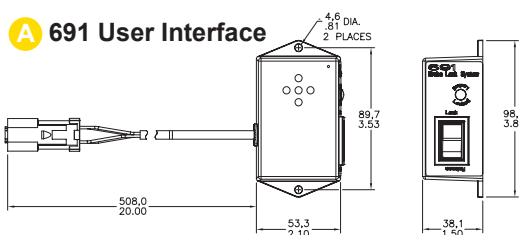

**E 691 Dual Actuator**

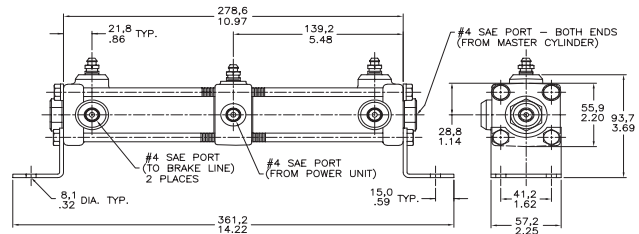

**B 691 Power Unit with  
C Control Module**

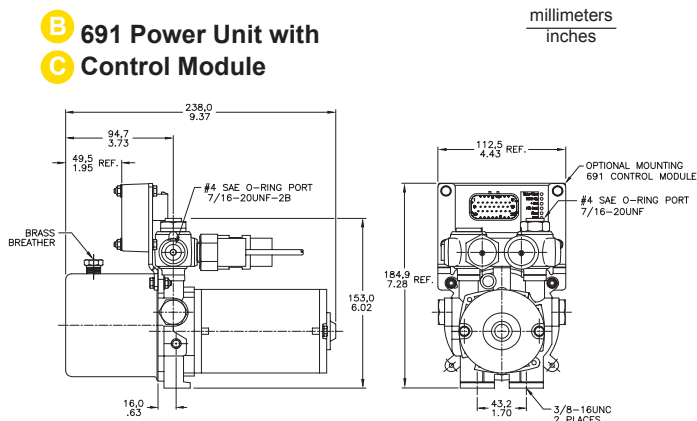

**D 691 Single Actuator**

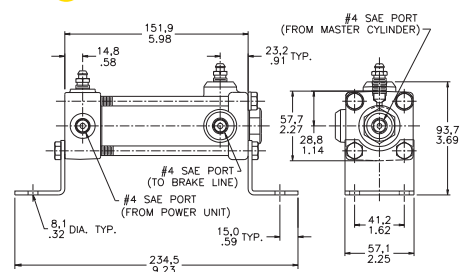

millimeters  
inches