

# Two-stage MASTER CYLINDER



## Bleeding Procedure

### NOTE

Be sure to maintain a high level of fluid in the reservoir during and after the entire bleeding process.

### PRESSURE BLEEDING INSTRUCTIONS

1. Mount the master cylinder on the machine and complete the push rod and pedal installation.
2. Make sure that there is at least 0.79 mm (0.031 in) play between the master cylinder piston and the push rod.
3. Fill the reservoir with proper fluid.

### CAUTION

When brake fluid is required, use only SAE J1703 or DOT brake fluid as specified by the vehicle manufacture. When hydraulic oil is required, use only mineral based hydraulic oil as specified by the vehicle manufacture. Never reuse brake fluid or hydraulic oil that has been drained from the system.

4. Be certain all fittings are tight to avoid leaking.
5. DO NOT DEPRESS THE PEDAL.
6. Connect the pressure bleeder to the reservoir adapter. Recommended bleeding pressure is 30 PSI maximum.
7. Open bleeder screw closest to the master cylinder outlet. Most of the air contained in the system will escape by this route. Close the bleeder screw.
8. Open the outermost bleeder screw from the master cylinder. When air bubbles disappear, close the bleeder screw.
9. Remove the pressure bleeder.
10. Open the bleeder screw at the master cylinder. Slowly depress the pedal to full stroke. Tighten the bleeder screw before permitting the pedal to return to a non-actuated position.
11. Actuate the pedal several times. If the pedal is spongy, repeat steps 3 through 11.

### BENCH BLEEDING INSTRUCTIONS

1. Remove the master cylinder the from the machine.
2. Position the master cylinder in a fixed-upright position in a vise.
3. Remove the filler cap assembly, not shown.
4. Connect one end of a length of tubing to the fitting block and immerse the other end below fluid level in the master cylinder reservoir. Keep the reservoir full.
5. Apply the master cylinder push rod full stroke. Repeat until air bubbles have ceased.
6. Remove brake tubing from the fitting block and reservoir. Install plugs and filler cap on the master cylinder.

### Two-stage Master Cylinders (with low pressure relief valve)

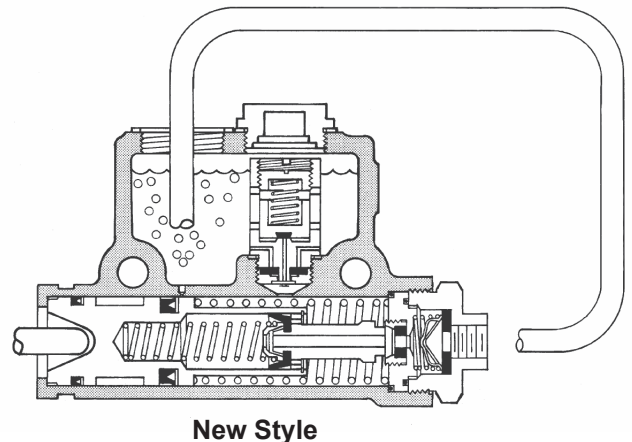
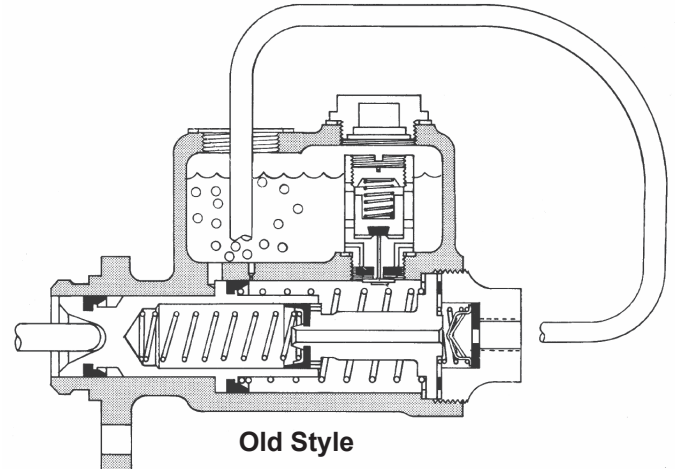

7. Install the master cylinder on the machine and connect the brake lines. Fill the master cylinder reservoir and bleed the wheel cylinders.
8. Be certain all fittings are tight to avoid leaking.

## NOTE

Be sure to maintain a high level of fluid in the reservoir during and after the entire bleeding process.

## PRESSURE BLEEDING INSTRUCTIONS

1. Mount the master cylinder on the machine and complete the push rod and pedal installation.
2. Make sure that there is at least 0.79 mm (0.031 in) play between the master cylinder piston and the push rod.
3. Fill the reservoir with proper fluid.

## ⚠ CAUTION

When brake fluid is required, use only SAE J1703 or DOT brake fluid as specified by the vehicle manufacture. When hydraulic oil is required, use only mineral based hydraulic oil as specified by the vehicle manufacture. Never reuse brake fluid or hydraulic oil that has been drained from the system.

4. Be certain all fittings are tight to avoid leaking.
5. DO NOT DEPRESS THE PEDAL.
6. Connect the pressure bleeder to the reservoir adapter. Recommended bleeding pressure is 30 PSI maximum.
7. Open the bleeder screw closest to the master cylinder outlet. Most of the air contained in the system will escape by this route. Close the bleeder screw.
8. Crack open the tube nut at elbow A and then close it when air is free from line.
9. Close the valve on the pressure bleeder and depress the pedal slowly while opening the bleeder closest to master cylinder.
10. Tighten the bleeder screw before permitting the pedal to return to a non-actuated position.
11. If the pedal is spongy, repeat steps 3 through 10. When the pedal is hard, top off with fluid from pressure bleeder and remove. **NOTE: On Two-stage Master Cylinders having a high pressure bore of 7/8 inch diameter or smaller, the bench bleeding method is recommended. If pressure bleeding is desired, bench bleed first.**

## BENCH BLEEDING INSTRUCTIONS

1. Remove the master cylinder from the machine. Position the master cylinder in a fixed-upright position in a vise.
2. Remove the filler cap assembly, not shown.
3. Connect one end of a length of tubing to the fitting block and immerse other end below fluid level in master cylinder reservoir. Keep the reservoir full.
4. Apply the master cylinder push rod full stroke. Repeat until air bubbles have ceased.
5. Plug outlet. Crack open the tube nut at elbow A and apply the push rod slowly. Tighten the tube nut when the line is free of air.

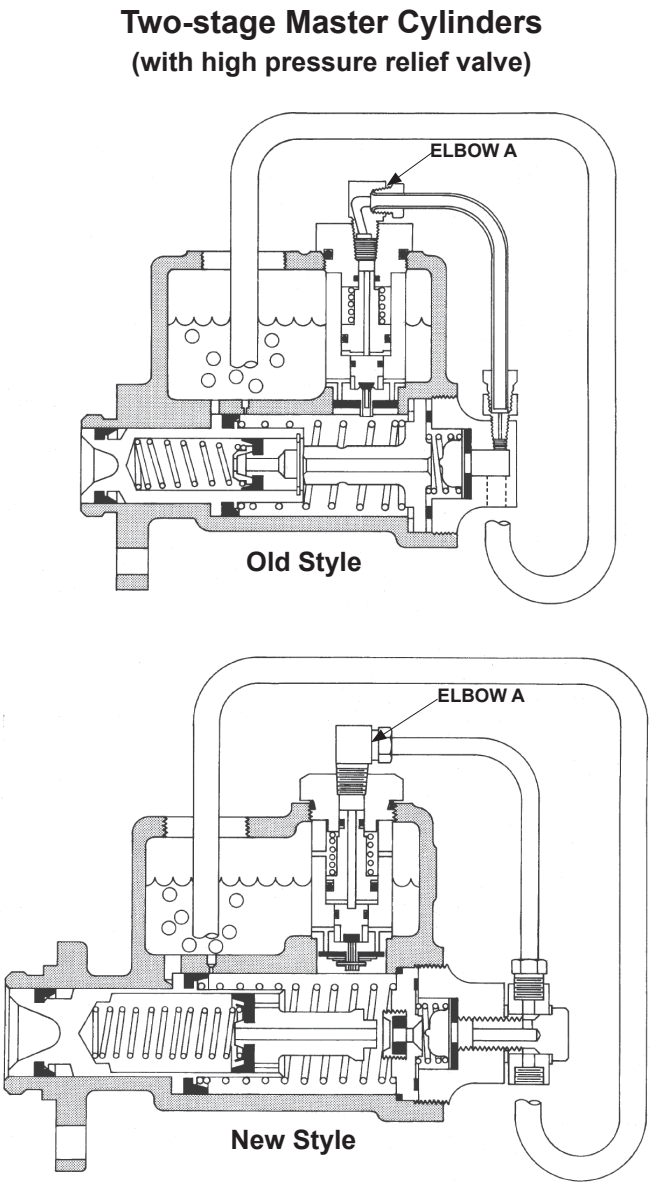

6. Remove brake tubing from the fitting block and reservoir. Install plugs and filler cap on the master cylinder.
7. Install the master cylinder on the machine and connect the brake lines. Fill the reservoir and bleed the wheel cylinders.
8. Be certain all fittings are tight to avoid leaking.

This publication is not subject to any update service. Information contained in this publication was in effect at the time the publication was approved for printing and is subject to change without notice or liability. ZF Off-Highway Solutions Minnesota Inc. reserves the right to revise the information presented or to discontinue the production of parts described at any time.

