



# MASTER CYLINDER

## Service Instructions

### DISASSEMBLY

1. Disconnect necessary fluid lines. Remove master cylinder from vehicle and drain fluid before disassembling.
2. Place the master cylinder in a soft jawed vise with end plug (10) facing up.
3. Remove end plug (10) from housing (3).

<b>⚠ CAUTION</b>
End plug (10) is under tension of spring (7).

4. Remove o-ring (8) and back-up ring (9) from end plug (10).
5. Remove spring (7) from housing (3).
6. Unscrew nut (1) and remove from push rod installed in piston (5). Be careful not to damage push rod.
7. Remove boot (2) from housing (3) and push rod.
8. Remove piston (5) through end plug (10) side of housing (3). **NOTE: Retaining ring, washer and push rod need not be removed from piston (5) unless damaged.**
9. Remove cups (4 & 6) from piston (5). Note direction of cups (4 & 6).
10. Remove two filler plugs (11) and two gaskets (12).

### ASSEMBLY

CLEAN ALL PARTS WITH CLEAN SOLVENT AND DRY. LUBRICATE ALL RUBBER PARTS WITH CLEAN SYSTEM FLUID PRIOR TO ASSEMBLY. BE SURE ENTIRE ASSEMBLY PROCEDURE IS DONE WITH CONTAMINATION FREE METHODS.

1. Check to be sure filler plug (11) breather hole is free of all contaminants. Use air pressure to clean and dry this hole. Install two new gaskets (12) and two filler plugs (11). Finger tighten filler plugs.
2. Install new cups (4 & 6) on piston (5). Note direction of pistons (4 & 6).
3. Install new back-up ring (9) and new o-ring (8) on end plug (10). Note order of back-up ring and o-ring.
4. Lubricate the threads of end plug (10). Install piston (5), spring (7), and end plug (10) in housing (3). Torque end plug (10) 67.8-108.5 N·m (50-80 lb-ft).
5. Install new boot (2) on push rod and housing (3).
6. Thread nut (1) on push rod and tighten securely.
7. See machine servicing instructions to properly reinstall master cylinder and connect fluid lines. Nut (1) may need adjustment according to machine manufacture servicing instructions.
8. Add fluid to the master cylinder reservoir. Bleed system of air. Tighten fittings if leaks occur. Make several applications to be sure cylinder is working properly. **NOTE: See form 81-600-001 instructions to bleed this cylinder. Refer to machine manufacture specifications to bleed machine brake system. All fittings must be inspected for leaks and tightened if leaks occur.**
9. After bleeding is completed, fill reservoir within 12.7 mm (0.50 in) of top. Torque the two filler plugs (11) 33.9-40.7 N·m (25-30 lb-ft).

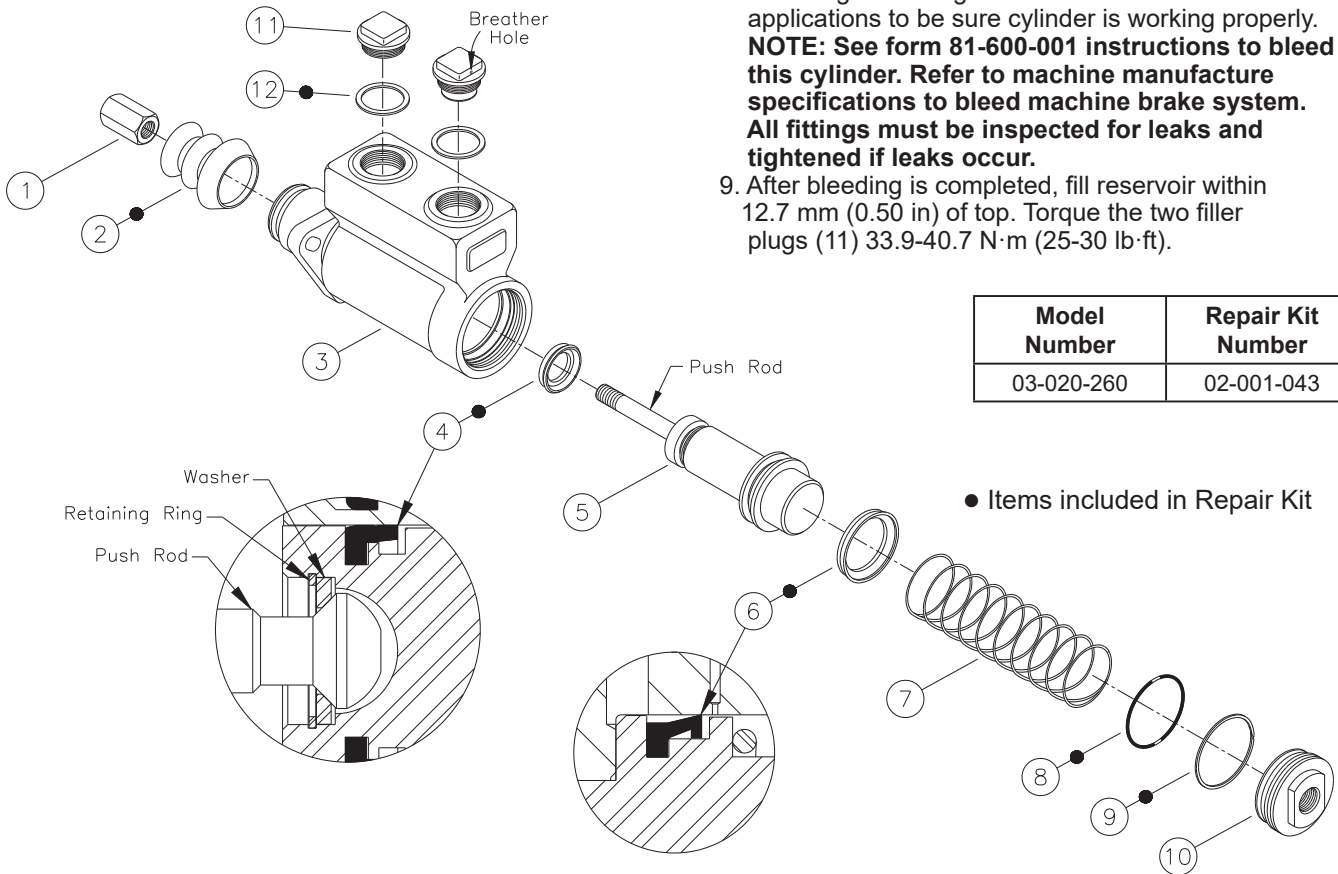

Model Number	Repair Kit Number
03-020-260	02-001-043

● Items included in Repair Kit

This publication is not subject to any update service. Information contained in this publication was in effect at the time the publication was approved for printing and is subject to change without notice or liability. ZF Off-Highway Solutions Minnesota Inc. reserves the right to revise the information presented or to discontinue the production of parts described at any time.

