

# MASTER CYLINDER

# MICO<sup>®</sup>

a **WABCO** company

## Service Instructions

### DISASSEMBLY

(Refer to Figures 1 and 2)

1. Remove the master cylinder from the machine by disconnecting the necessary fluid lines. Disconnect the push rod and remove the mounting bolts. Drain fluid from the assembly.
2. **Earlier Design:** Remove plug (1) and spring (3) from housing (8). Remove o-ring (2) from plug (1).  
**Later Design:** Remove plug (1) and spring (3) from housing (8). Remove o-ring (2) from housing (8) bore.
3. Remove piston assembly (4) from housing (8). Remove cups (5 & 7) from piston (6). **NOTE: Be careful not to scratch or mar piston (6).**
4. Remove filler caps (9 & 11) and gaskets (10) from housing (8).
5. Remove plug assembly (12) and gasket (19) from inside housing (8) reservoir.
6. Remove retaining ring (18), retainer (17), spring (16), ball (15), and o-ring (14) from plug (13). Note direction of spring (16). See Figure 2.

### ASSEMBLY

(Refer to Figures 1 and 2)

LUBRICATE ALL RUBBER COMPONENTS FROM THE REPAIR KIT WITH CLEAN TYPE FLUID USED IN THE SYSTEM.

1. Clean all parts thoroughly before assembling.
2. Install new o-ring (14), new ball (15), new spring (16), new retainer (17), and new retaining ring (18) in plug (13). Note the direction of spring (16). See Figure 2.
3. Install new gasket (19) and plug assembly (12) in housing (8) reservoir. Torque plug assembly (12) 40.7-47.5 N·m (30-35 lb-ft).
4. Install new gasket (10) and filler cap (11) on housing (8).
5. **NOTE: Before installing filler cap (9) be sure the filler cap breather hole is free of all contaminants. Use air pressure to clean and dry this hole.** Install new gasket (10) and filler cap (9) on housing (8).
6. Install new cups (5 & 7) on piston (6). Note the direction of cup (7). See Figure 2. **NOTE: Be careful not to scratch or mar piston (6).**
7. **Earlier Design:** Lubricate the threads on plug (1). Install new o-ring (2) on plug (1). Install spring (3) and plug (1) in housing (8). Torque plug (1) 67.8-108.5 N·m (50-80 lb-ft).  
**Later Design:** Lubricate the threads on plug (1). Install new o-ring (2) in housing (8) bore. Install spring (3) and plug (1) in housing (8). Torque plug (1) 67.8-108.5 N·m (50-80 lb-ft).
8. Install unit on machine and connect fluid lines.

Fill reservoir and bleed system of air. See MICO form 81-001-002 instructions to bleed this cylinder. Refer to machine manufacture specifications to bleed vehicle brake system. Tighten fittings if leaks occur. Make several applications to be sure the master cylinder is working properly. **NOTE: All fittings must be inspected for leaks and tightened if leaks occur.**

9. After bleeding the system, fill the reservoir to within 12.7 mm (0.50 in) of the top. Install the filler plugs and torque 33.9-47.5 N·m (25-35 lb-ft).

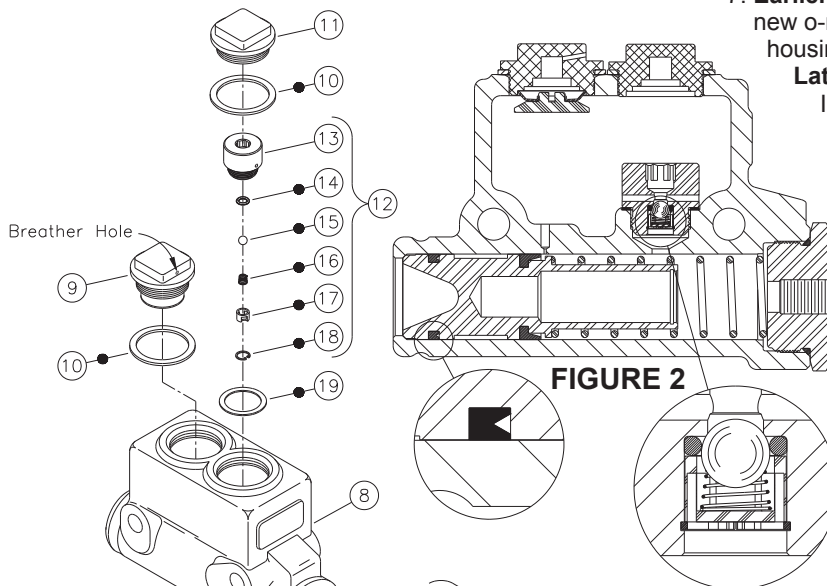

FIGURE 2

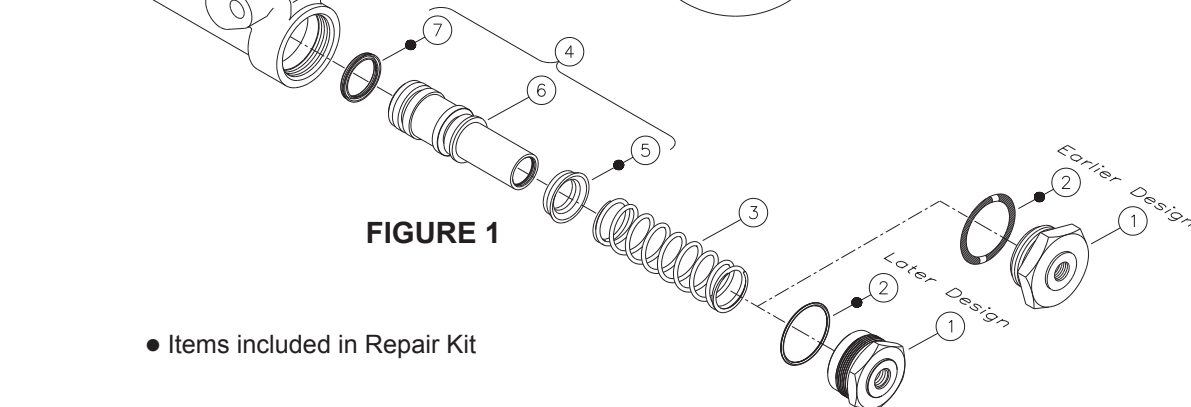

FIGURE 1

● Items included in Repair Kit

This document is intended to provide general information about MICO Products. MICO, Inc. has attempted to present accurate information about MICO Products in its catalogs, brochures, and other printed materials. MICO, Inc. is not responsible for errors, inaccuracies, or inconsistencies that may exist in any catalog, brochure, or other printed materials or any damages arising from or related to reliance on information in them. Materials and specifications for MICO Products set forth in catalogs, brochures, and other printed materials are subject to change without notice or obligation. Refer to [www.mico.com](http://www.mico.com) for the most recent versions of our literature. If you have any questions concerning MICO Products, please contact MICO, Inc. All MICO Products and service are sold and provided subject to the MICO Warranty at [www.mico.com](http://www.mico.com) in effect on the date of sale or supply.

MICO is a trademark and registered trademark of MICO, Inc. MICO is registered in the U.S. Patent and Trademark Office as well as in Australia, Canada, Indonesia, Japan, Peoples Republic of China, South Korea, and the European Community.



**MICO, Inc.**

1911 Lee Boulevard / North Mankato, MN U.S.A. 56003-2507

**Tel:** +1 507 625 6426 **Fax:** +1 507 625 3212

Form No. 81-001-059

Revised 2016-11-30

[www.mico.com](http://www.mico.com)