

BOOSTED MASTER CYLINDER (Master Cylinder Section)



Service Instructions

MASTER CYLINDER SECTION - Automotive Brake Fluid

POWER ASSIST SECTION - Mineral Base Hydraulic Oil

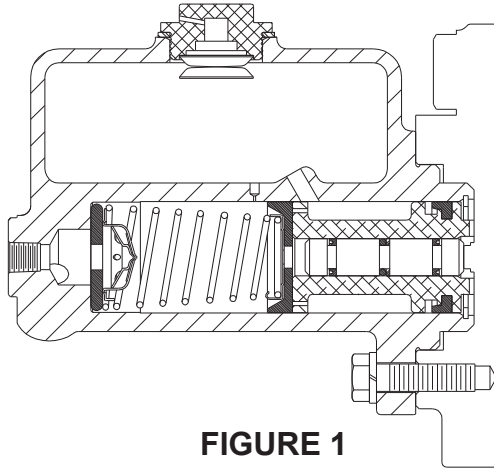

FIGURE 1

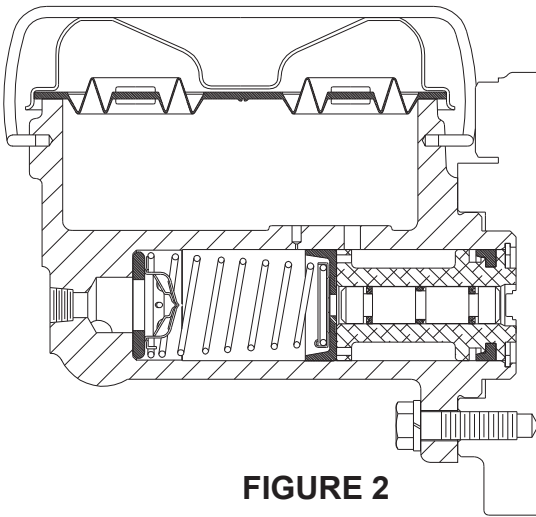
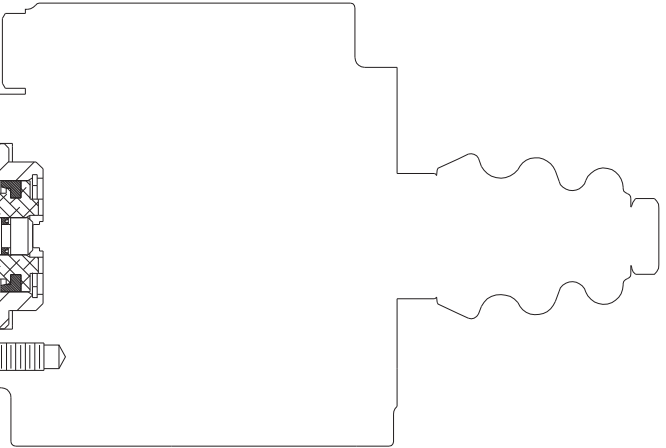
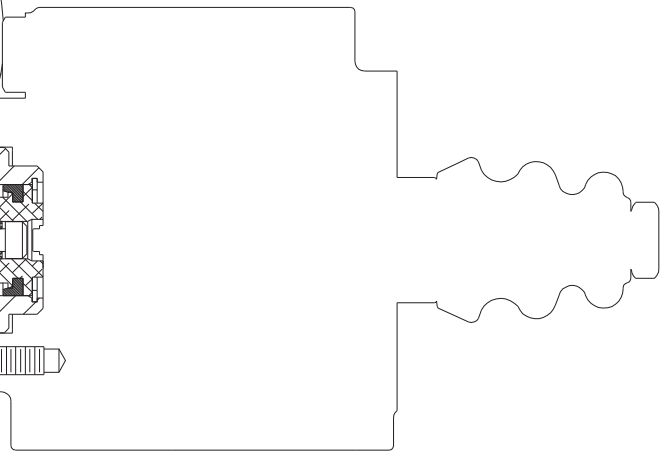

FIGURE 2



This instruction sheet services the Master Cylinder Section for these model numbers:

02-460-216	02-460-246	02-460-308	02-460-420
02-460-226	02-460-280	02-460-316	02-460-436
02-460-232	02-460-286	02-460-334	02-460-478
02-460-234	02-460-298	02-460-336	02-460-492
02-460-242	02-460-304	02-460-406	02-460-622

NOTE: If your product number is not listed, contact ZF Off-Highway Solutions Minnesota Inc. for information.

TYPICAL SYSTEM SCHEMATIC

(This circuit may not apply to your installation)

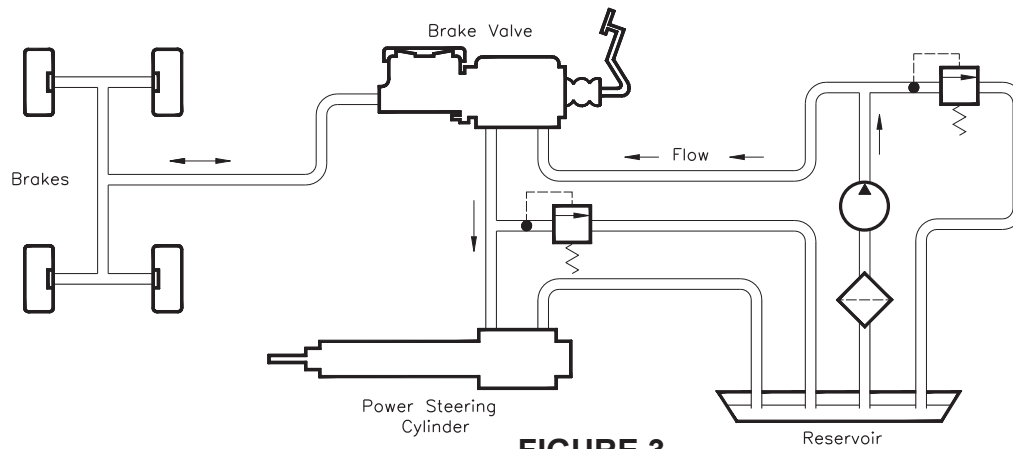
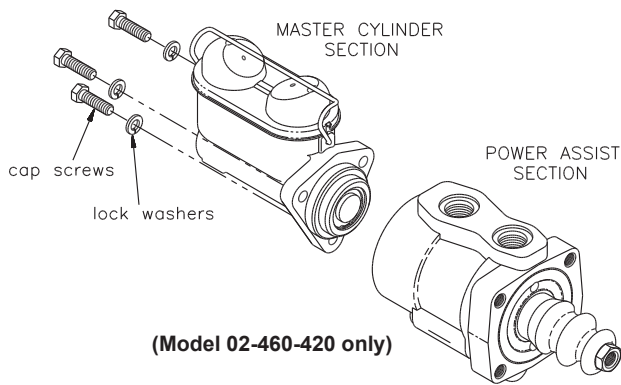

FIGURE 3

REMOVING MASTER CYLINDER FROM THE MACHINE AND SEPARATING SECTIONS

(Refer to Figures 1, 2, and 4)

1. Remove master cylinder assembly from machine by disconnecting the necessary fluid lines, disconnecting the push rod, and removing the mounting bolts. Drain fluid from the assembly.
2. Separate the master cylinder section from the power assist section by removing three cap screws and three lock washers.



(Model 02-460-420 only)

FIGURE 4

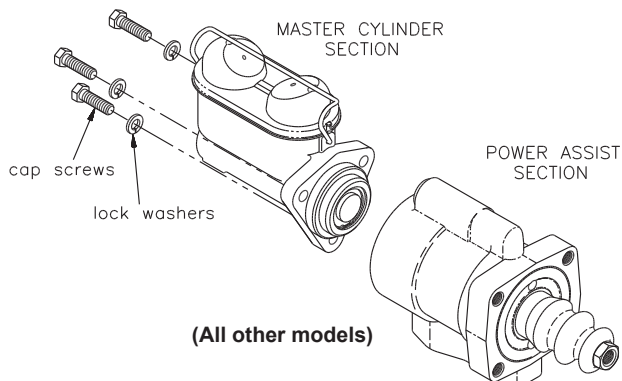

(All other models)

MASTER CYLINDER DISASSEMBLY

(Refer to Figures 1, 2, and 5)

1. Drain fluid from unit before disassembling.
2. Remove retaining ring (1) from housing (11 or 14).

CAUTION

Retaining ring is under tension of spring (8).

3. Remove piston assembly (5) from cylinder bore.
4. Remove cup (6), retainer (7), spring (8) check valve (9) and seat (10) from housing. **NOTE: Not all cylinders use check valve (9) and seat (10).**
5. Remove line bolt (18), gaskets (19 & 21) and fitting block (20) from housing (11 or 14). **NOTE: Not all models use line bolt (18), gaskets (19 & 21) and fitting block (20).**
6. If you have housing (11), remove filler cap (13), and gasket (12).
7. If you have housing (14), remove hook (17), cover (16), and diaphragm (15).

MASTER CYLINDER ASSEMBLY

(Refer to Figures 1, 2, and 5)

Use only automotive brake fluid in master cylinder section.

LUBRICATE ALL RUBBER COMPONENTS FROM REPAIR KIT WITH CLEAN TYPE FLUID USED IN THE SYSTEM.

1. Clean all parts thoroughly before assembling.
2. Install new seat (10) and new check valve (9) in bore of housing (11 or 14). **NOTE: Not all models use check valve (9) and seat (10). Install these items only if originally used in your model.**
3. Attach new retainer (7) to small end of new spring (8) and install into housing bore with large end of spring over check valve (9).
4. Install new cup (6) over retainer (7). Note direction of cup.
5. Insert new piston assembly (5) in housing bore. Note direction of piston assembly.
6. Install new retaining ring (1) on housing.

- Items included in Repair Kit 02-400-058
- * Not used in all models

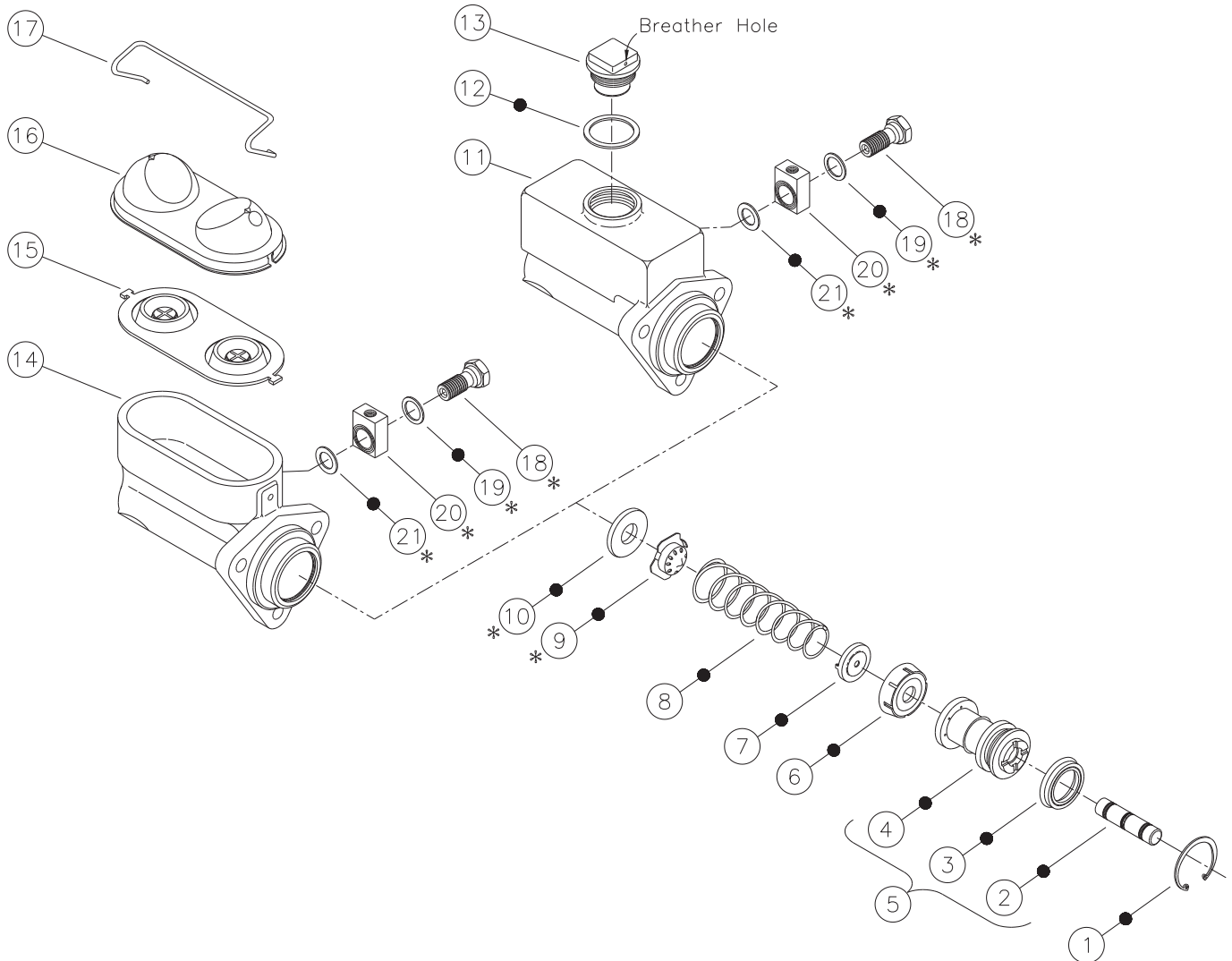

FIGURE 5

7. Install fitting block (20), new gaskets (19 & 21) and line bolt (18). Finger tighten line bolt (18). **NOTE: Not all models use fitting block (20), gaskets (19 & 21), and line bolt (18).**
8. If you have housing (11), install new gasket (12) and filler cap (13). **NOTE: Before installing filler cap (13) be sure the filler cap breather hole is free of all contaminants. Use air pressure to clean and dry this hole.**
9. If you have housing (14), install diaphragm (15), cover (16) and hook (17).

CONNECTING SECTIONS AND MOUNTING MASTER CYLINDER ON THE MACHINE

(Refer to Figures 1, 2, and 4)

1. Attach the master cylinder section to the power assist section with three cap screws and three lock washers. Torque the cap screws 29.8-36.6 N·m (22-27 lb·ft).
2. Install unit on the machine and connect the fluid lines. Torque line bolt (18) 47.5-61.0 N·m (35-45 lb·ft). **NOTE: Hold fitting block (20) in the proper position while tightening line bolt. Connect the push rod. Fill the reservoir and bleed the system of air. Tighten fittings if leaks occur. Make several applications to be sure the master cylinder is working properly. NOTE: All fittings must be inspected for leaks and tightened if leaks occur.**

BLEEDING PROCEDURES

NOTE

Use only proper fluid specified by the machine manufacture. Never reuse fluid that has been drained from the system. Be sure that you maintain a high level of fluid in the reservoir during and after the entire bleeding process.

PRESSURE BLEEDING INSTRUCTIONS

1. The master cylinder must be mounted to the power assist section.
2. Fill the reservoir with the proper fluid.
3. Be certain all fittings are tight to avoid leaking.
4. DO NOT DEPRESS THE PEDAL.
5. Connect pressure bleeder to the reservoir adapter. Recommended bleeding pressure is 2.07 bar (30 PSI) maximum. **NOTE: Make sure to use the correct pressure bleeder for the type fluid used in the system.**
6. Open the bleeder screw closest to the master cylinder outlet. Most of the air contained in the system will escape by this route. Close the bleeder screw.
7. Continue to the next bleeder screw and so on. At each point when air bubbles disappear close the bleeder screw.
8. Remove the pressure bleeder.
9. Open the bleeder screw at the master cylinder. Actuate the cylinder to remove any residual air. Tighten the bleeder screw before permitting the pedal to return.
10. Actuate the pedal several times. If the pedal is spongy, check for system leaks and repeat bleeding process.
11. Fill the reservoir to within 12.7 mm (0.50 in) of top. Install filler cap and torque 33.9-40.7 N·m (25-30 lb·ft).

BENCH BLEEDING INSTRUCTIONS

(Refer to Figure 6)

1. This process can be done in a bench vise or on the machine with the master cylinder mounted to power assist section.
2. Remove the master cylinder filler cap.
3. Connect a length of tubing to an outlet port and immerse the other end below the fluid level in the master cylinder reservoir. Keep the reservoir fluid within 12.7 mm (0.50 in) of inside reservoir top.
4. Actuate the master cylinder piston with a smooth object large enough to hold the small internal piston from coming out. Slowly stroke and release master cylinder piston. **See CAUTION below.** Repeat until air bubbles in reservoir have ceased.
5. Remove tubing. This should be done quickly so the loss of fluid will be minimized.
6. If cylinder was bench bled in a vise, it must now be attached securely to the power assist section and mounted on machine. Finish all plumbing connections before continuing to step 7.
7. Bleed remaining air from system by depressing brake pedal and opening bleeder fitting closest to master cylinder. Close bleeder fitting before

- brake pedal is released. Continue to next bleeder port. In all cases the bleeder fittings must be closed before the brake pedal is released or air will be pulled in through the bleeder and ingest unwanted air in the system.
8. Fill reservoir to within 12.7 mm (0.50 in) of top. Install filler cap and torque 33.9-40.7 N·m (25-30 lb·ft).
9. Be sure all fittings are tight to avoid any leaking.
10. Depress pedal several times. If the brake pedal feels spongy, check for system leaks and repeat bleeding process.

CAUTION

Care must be taken so as not to over stroke this cylinder. The cylinder does not incorporate a piston stop. Over stroking this cylinder may cause it to leak from push rod end of cylinder. Maximum recommended stroke for this cylinder is 31.8 mm (1.25 in).

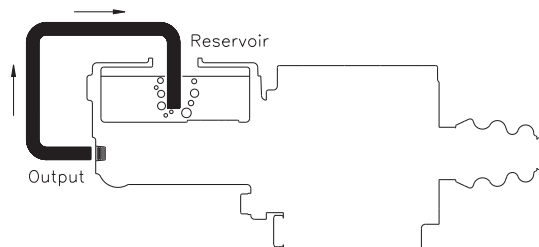

FIGURE 6

This publication is not subject to any update service. Information contained in this publication was in effect at the time the publication was approved for printing and is subject to change without notice or liability. ZF Off-Highway Solutions Minnesota Inc. reserves the right to revise the information presented or to discontinue the production of parts described at any time.

