

BOOSTED MASTER CYLINDER (Master Cylinder Section)



Service Instructions

TABLE 1

Model Number	Master Cylinder Repair Kit Number	Model Number	Master Cylinder Repair Kit Number
02-460-238	02-400-081	02-460-354	02-400-107
02-460-244	02-400-107	02-460-368	02-400-158
02-460-248	02-400-081	02-460-422	02-400-081
02-460-310	02-400-135	02-460-434	02-400-081
02-460-320	02-400-158	02-460-440	02-400-081
02-460-352	02-400-107	02-460-498	02-400-107

NOTE: If your product number is not listed, contact ZF Off-Highway Solutions Minnesota Inc. for information.

MASTER CYLINDER SECTION - Automotive Brake Fluid

POWER ASSIST SECTION - Mineral Base Hydraulic Oil

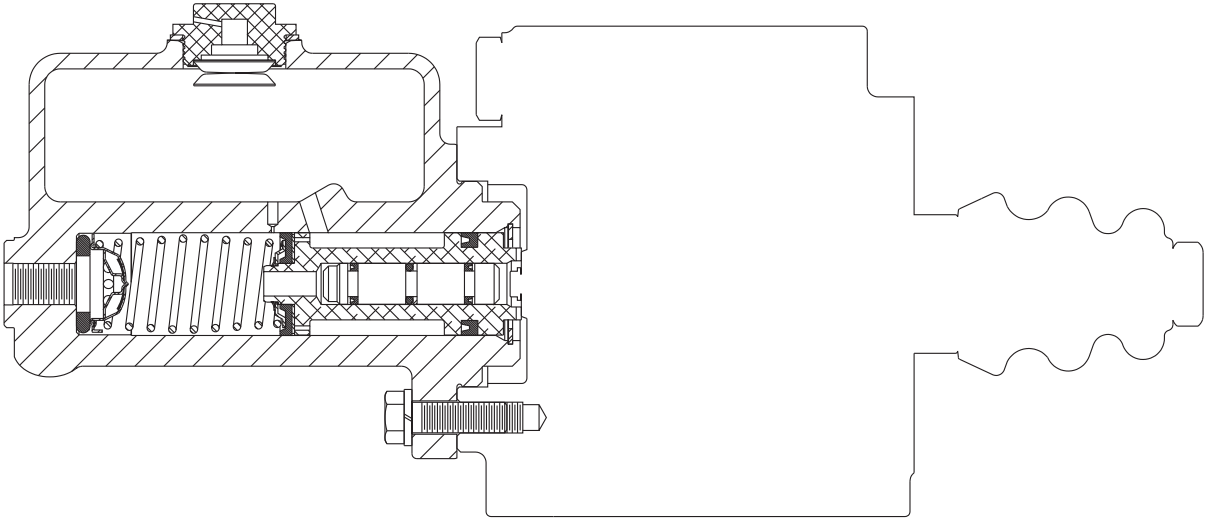

FIGURE 1
(02-460-238 Shown)

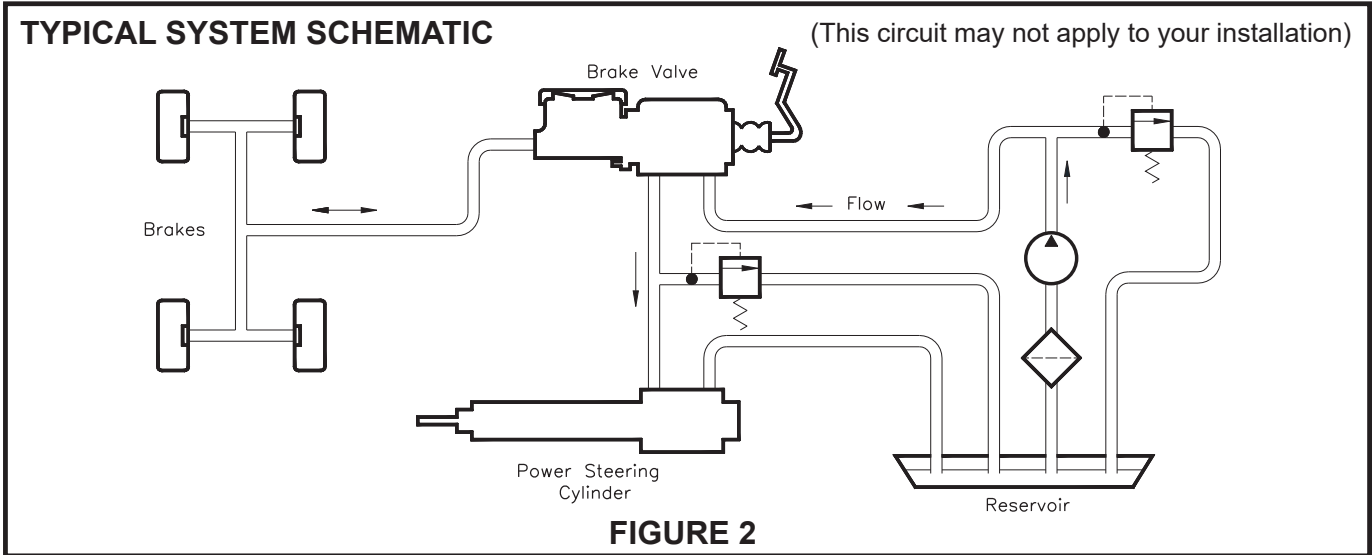

FIGURE 2

REMOVING MASTER CYLINDER FROM THE MACHINE AND SEPARATING SECTIONS

(Refer to Figures 1, 3, and 4)

1. Remove the master cylinder assembly from the machine by disconnecting the necessary fluid lines, disconnecting the push rod, and removing the mounting bolts. Drain the fluid from the assembly.
2. Separate the master cylinder section from the power assist section by removing three cap screws and three lock washers.

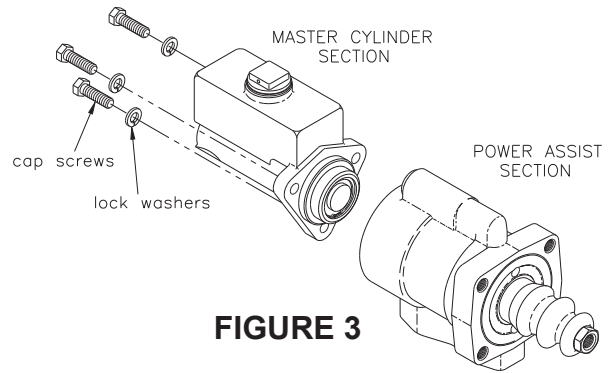

FIGURE 3

CONNECTING SECTIONS AND MOUNTING MASTER CYLINDER ON THE MACHINE

(Refer to Figures 1, 3, and 4)

1. Attach the master cylinder Section to the power assist section with three cap screws and three lock washers. Torque cap screws 29.8-36.6 N·m (22-27 lb·ft).
2. Install the master cylinder assembly on the machine. Connect the push rod. Connect the fluid lines. Fill the reservoir and bleed the system of air. Tighten fittings if leaks occur. Make several applications to be sure the master cylinder is working properly. **NOTE: All fittings must be inspected for leaks and tightened if leaks occur.**

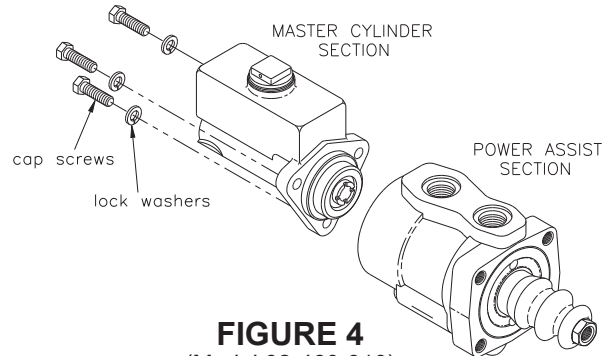

FIGURE 4

(Model 02-460-310)

NOTE

This literature services several master cylinder models. The components shown in Figures 1-5 may appear different than what is found in your brake.

DISASSEMBLY

(Refer to Figure 5)

1. Drain fluid from unit before disassembling.
2. Remove retaining ring (1) from housing (7). **NOTE: Retaining ring is under tension of spring(s) (3 & 4).**
3. Remove piston assembly (2) from housing bore.
4. Remove springs (3 & 4), check valve (5), and seat (6) from housing bore. **NOTE: Not all models use spring (3).**
5. Remove filler cap (9) and gasket (8) from housing.

ASSEMBLY

(Refer to Figure 5)

Use only automotive brake fluid in the master cylinder section.

LUBRICATE ALL RUBBER COMPONENTS FROM THE REPAIR KIT WITH CLEAN TYPE FLUID USED IN THE SYSTEM.

1. Clean all parts thoroughly before assembling.
2. Insert new seat (6), new check valve (5), and springs (3 & 4) into housing bore. **NOTE: Not all models use spring (3). Install new springs (3 & 4) if found in repair kit.**
3. Insert new piston assembly (2) into housing bore.
4. Install new retaining ring (1).
5. **NOTE: Before installing filler cap (9) be sure the filler cap breather hole is free of all contaminants. Use air pressure to clean and dry this hole.** Install new gasket (8) and filler cap (9) on housing. Finger tighten filler cap (9).

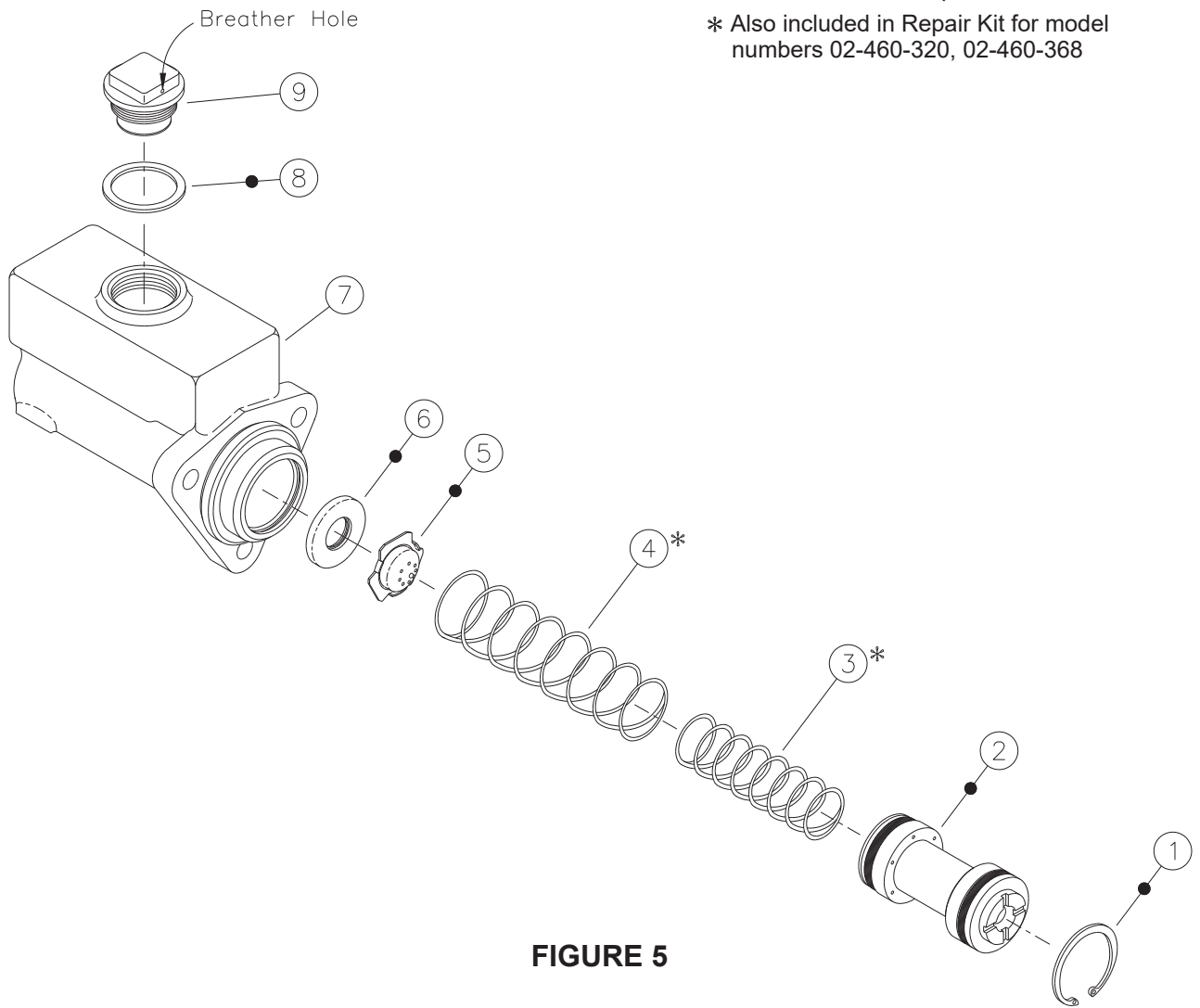

- Items included in Repair Kit
- * Also included in Repair Kit for model numbers 02-460-320, 02-460-368

FIGURE 5

BLEEDING PROCEDURES

NOTE

Use only proper fluid specified by the machine manufacture. Never reuse fluid that has been drained from the system. Be sure that you maintain a high level of fluid in the reservoir during and after the entire bleeding process.

PRESSURE BLEEDING INSTRUCTIONS

1. Master cylinder must be mounted to power assist section.
2. Fill the reservoir with proper fluid.
3. Be certain all fittings are tight to avoid leaking.
4. DO NOT DEPRESS PEDAL.
5. Connect pressure bleeder into reservoir adapter. Recommended bleeding pressure is 2.07 bar (30 PSI) maximum. **NOTE: Make sure to use correct pressure bleeder for type fluid used in system.**
6. Open bleeder screw closest to master cylinder outlet. Most of the air contained in the system will escape by this route. Close bleeder screw.
7. Continue to the next bleeder screw and so on. At each point when air bubbles disappear close the bleeder screw.
8. Remove the pressure bleeder.
9. Open the bleeder screw at the master cylinder. Actuate cylinder to remove any residual air. Tighten the bleeder screw before permitting the pedal to return.
10. Actuate pedal several times. If the pedal is spongy, check for system leaks and repeat bleeding process.
11. Fill the reservoir to within 12.7 mm (0.50 in) of top. Install filler cap and torque 33.9-40.7 N·m (25-30 lb·ft).

BENCH BLEEDING INSTRUCTIONS

(Refer to Figure 6)

1. This process can be done in a bench vise or on the machine with master cylinder mounted to power assist section.
2. Remove master cylinder filler cap.
3. Connect a length of tubing to an outlet port and immerse the other end below the fluid level in the master cylinder reservoir. Keep reservoir fluid within 12.7 mm (0.50 in) of inside reservoir top.
4. Actuate master cylinder piston with a smooth object large enough to hold the small internal piston from coming out. Slowly stroke and release master cylinder piston. **See CAUTION below.** Repeat until air bubbles in reservoir have ceased.
5. Remove tubing. This should be done quickly so the loss of fluid will be minimized.
6. If the cylinder was bench bled in a vise, it must now be attached securely to the power assist section and mounted on the machine. Complete all plumbing connections before continuing to step 7.
7. Bleed the remaining air from the system by depressing brake pedal and opening bleeder fitting closest to the master cylinder. Close the bleeder fitting before the brake pedal is released. Continue to

- the next bleeder port. In all cases the bleeder fittings must be closed before the brake pedal is released or air will be pulled in through the bleeder and ingest unwanted air into the system.
8. Fill the reservoir to within 12.7 mm (0.50 in) of top. Install the filler cap and and torque 33.9-40.7 N·m (25-30 lb·ft).
9. Be sure all fittings are tight to avoid any leaking.
10. Depress the pedal several times. If the brake pedal feels spongy, check for system leaks and repeat bleeding process.

CAUTION

Care must be taken so as not to over stroke this cylinder. The cylinder does not incorporate a piston stop. Over stroking this cylinder may cause it to leak from push rod end of cylinder. Maximum recommended stroke for this cylinder is 31.8 mm (1.25 in).

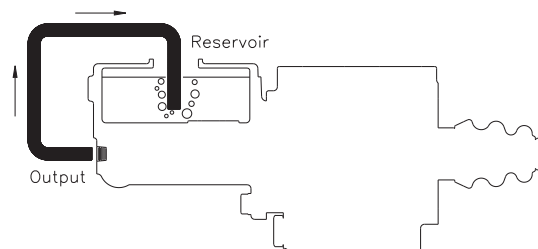

FIGURE 6

This publication is not subject to any update service. Information contained in this publication was in effect at the time the publication was approved for printing and is subject to change without notice or liability. ZF Off-Highway Solutions Minnesota Inc. reserves the right to revise the information presented or to discontinue the production of parts described at any time.



ZF Off-Highway Solutions Minnesota Inc.

1911 Lee Boulevard / North Mankato, MN U.S.A. 56003

Tel: +1 507 625 6426 Fax: +1 507 625 3212